

Body builder guidelines  
March 2024 edition



Nutzfahrzeuge

# Body builder guidelines

## The Multivan (from model year 2022)



# Table of contents

<b>1 General information</b>	<b>5</b>
<b>1.1 Introduction</b>	<b>5</b>
1.1.1 Concept of these guidelines	5
1.1.2 Means of representation	6
1.1.3 Vehicle safety	7
1.1.4 Operational safety	8
1.1.5 Note on copyright	8
<b>1.2 General notes</b>	<b>9</b>
<b>1.2.1 Product and vehicle information for body builders</b>	<b>9</b>
1.2.1.1 Contact in Germany	9
1.2.1.2 International contact	9
1.2.1.3 Electronic repair and workshop information from Volkswagen AG (erWin*)	9
1.2.1.4 Genuine Parts Online Ordering Portal*	10
1.2.1.5 Online Owner's Manual	10
1.2.1.6 European Type Approval (ETA) and EC Certificate of Conformity (CoC)	10
1.2.1.7 Worldwide Harmonised Light Vehicles Test Procedure (WLTP)	11
1.2.1.8 WLTP homologation for upgrades/conversions	11
1.2.1.9 Manufacturer's declaration	11
<b>1.2.2 Body builder guidelines, consulting</b>	<b>11</b>
1.2.2.1 Letter of non-objection	12
1.2.2.2 Application for the letter of non-objection	14
1.2.2.3 Legal entitlements	15
<b>1.2.3 Warranty and product liability of the body builder</b>	<b>15</b>
<b>1.2.4 Ensuring traceability</b>	<b>16</b>
<b>1.2.5 Trademarks</b>	<b>16</b>
1.2.5.1 Positions on rear of the vehicle	16
1.2.5.2 Appearance of overall vehicle	16
1.2.5.3 Non-Volkswagen trademarks	16
<b>1.2.6 Recommendations for vehicle storage</b>	<b>16</b>
<b>1.2.7 Compliance with environmental rules and regulations</b>	<b>19</b>
<b>1.2.8 Recommendations for inspection, maintenance and repair</b>	<b>20</b>
<b>1.2.9 Accident prevention</b>	<b>20</b>
<b>1.2.10 Quality system</b>	<b>21</b>
<b>1.3 Planning bodies</b>	<b>22</b>
1.3.1 Selecting the base vehicle	22
1.3.2 Vehicle modifications	23
1.3.3 Vehicle acceptance	24
<b>1.4 Optional equipment</b>	<b>25</b>
<b>2 Technical data for planning</b>	<b>26</b>
<b>2.1 Base vehicle</b>	<b>26</b>
<b>2.1.1 Vehicle dimensions</b>	<b>26</b>
2.1.1.1 Multivan basic data	26
<b>2.1.2 Ramp angle and breakover angle</b>	<b>29</b>
<b>2.2 Running gear</b>	<b>30</b>
<b>2.2.1 Permitted weights and unladen weights</b>	<b>30</b>
<b>2.2.2 Turning circle</b>	<b>31</b>
<b>2.2.3 Authorised tyre sizes</b>	<b>31</b>
<b>2.2.4 Modifications to axles</b>	<b>31</b>

2.2.5 Modifications to the steering system .....	31
2.2.6 Brake system and brake control system ESC* .....	32
2.2.6.1 General information .....	32
2.2.6.2 Routing additional lines along the brake hoses/brake lines.....	32
2.2.7 Modification of springs, suspension mounting, dampers.....	32
2.2.8 Wings and wheel housings.....	32
2.3 Body-in-white .....	33
2.3.1 Roof loads .....	33
2.3.1.1 Dynamic roof loads.....	33
2.3.1.2 Static roof loads .....	33
2.3.2 Modifications to the body-in-white.....	33
2.3.2.1 Screw connections.....	33
2.3.2.2 Welding work.....	35
2.3.2.3 Welded connections .....	37
2.3.2.4 Selection of welding process.....	37
2.3.2.5 Spot welding .....	38
2.3.2.6 Shielding gas hole spot welding .....	39
2.3.2.7 Tacking.....	40
2.3.2.8 Welding is not allowed .....	40
2.3.2.9 Corrosion protection after welding .....	40
2.3.2.10 Corrosion protection measures.....	40
2.3.2.11 Planning measures .....	41
2.3.2.12 Component design measures.....	42
2.3.2.13 Coating measures .....	42
2.3.2.14 Work on the vehicle.....	42
2.4 Interior .....	43
2.4.1 Modifications in the area of airbags.....	43
2.4.2 Modifications in the area of seats.....	43
2.4.2.1 Belt anchors .....	44
2.4.3 Forced ventilation.....	44
2.4.4 Acoustic insulation .....	44
2.4.5 eCall Emergency System .....	44
2.5 Electrics/electronics.....	45
2.5.1 Lighting .....	45
2.5.1.1 Vehicle lighting devices .....	45
2.5.1.2 Adjusting the headlights.....	47
2.5.1.3 Special lights .....	47
2.5.2 Vehicle electrical system.....	48
2.5.2.1 Electrical wiring / fuses.....	48
2.5.2.2 Additional circuits .....	49
2.5.2.3 Retrofitting electrical devices .....	50
2.5.2.4 Electromagnetic compatibility .....	52
2.5.2.5 Mobile communication systems .....	52
2.5.2.6 CAN bus .....	53
2.5.2.7 Current and signal take-off of vehicle electrical system potentials .....	54
2.5.3 Electrical interface for special vehicles .....	57
2.5.3.1 General notes on the interface for special vehicles .....	58
2.5.3.2 Customer-specific functional control unit (CFCU) .....	59
2.5.3.3 Overview of functions of customer-specific functional control unit, basic version .....	60
2.5.4 Vehicle battery.....	62

2.5.5 Retrofitting of alternators.....	63
2.5.6 Driver assist systems.....	64
2.5.7 Earth points.....	65
2.6 Engine peripherals / drive train.....	66
2.6.1 Engine / drive train components.....	66
2.6.2 Drive shafts.....	66
2.6.3 Fuel system.....	66
2.6.4 Exhaust system.....	68
2.6.4.1 Exhaust system (MAR*).....	69
2.6.5 SCR system (Euro 6).....	71
2.6.5.1 Installation position of the AdBlue® tank in the vehicle.....	72
2.6.5.2 Filling opening of the AdBlue® tank.....	72
2.7 Add-ons/units.....	74
2.7.1 Roof carriers.....	74
2.7.2 Towing brackets.....	75
2.7.2.1 Maximum trailer weights.....	75
2.7.2.2 Retrofitting a trailer towing bracket.....	75
2.8 Raising the vehicle.....	76
3 Modifications to closed bodies.....	77
3.1 Interior.....	77
3.1.1 Safety features.....	77
3.1.2 Retrofitting seats.....	78
3.1.2.1 Installation of standard seats.....	78
3.1.2.2 Installation of aftermarket product seats or use of standard seats deviating from the standard seating.....	79
4 Implementations of special bodies.....	80
4.1 Vehicles for transporting persons with restricted mobility.....	80
4.1.1 Base vehicle equipment.....	80
4.1.2 Selection of steering rack for conversions for people with disabilities.....	80
4.1.3 Notes on conversion solutions for the wheelchair transporter.....	81
4.1.4 Notes on installing manual operating devices for the foot brake:.....	81
4.1.5 Deactivating airbags / belt tensioner systems.....	81
4.2 Taxi / private hire car.....	83
4.2.1 Preparation ex works for taxis and private hire cars.....	83
4.3 Plug-in hybrid electric vehicle (PHEV).....	84
4.3.1 High-voltage system.....	84
5 Technical data.....	87
5.1 Build dimension drawings.....	87
5.2 Diagrams (foil templates).....	88
5.3 Current flow diagrams.....	89
5.4 CAD models.....	90
6 Weights (masses).....	91
7 Homologation.....	92
7.1 Notes on homologation of modifications and conversions.....	92
8 Listings.....	93
8.1 List of changes.....	93

\*Electronic Stability Control

# 1 General information

## 1.1 Introduction

These body builder guidelines provide body builders with important technical information which must be complied with when planning and manufacturing a body for road safety and operational reliability. The add-on, body, installation or conversion work required for this is referred to below as “body activities”.

Due to the vast number of body builders and types of conversion, it is not possible for Volkswagen AG to predict all possible changes which may occur due to the body activities, e.g. with regard to driving properties, stability, weight distribution, centre of gravity of the vehicle and its handling characteristics. Therefore, Volkswagen AG does not accept any liability for accidents or injuries arising from changes of this kind made to its vehicles, especially if the changes have a negative effect on the vehicle as a whole. As a result, Volkswagen AG only accepts liability for its own design, production and instruction services. The body builder itself is obliged to ensure that its body activities are not faulty in themselves, and also that they cannot result in defects or dangers on the vehicle as a whole. The body builder must also ensure the conformity of the body activities with the respective and applicable laws (in particular approval and registration processes). The body builder itself is liable in the event that this obligation is violated.

These body builder guidelines are intended for professional body builders. As a result, these body builder guidelines assume corresponding background knowledge. Note that some work (e.g. welding on load-bearing parts) is only allowed to be performed by appropriately qualified personnel. This requirement exists in order to avoid risks of injury and to achieve the quality needed in the body activities.

### 1.1.1 Concept of these guidelines

The following body builder guidelines are divided into 8 chapters so that you can find information rapidly:

1. Introduction
2. Technical data for planning
3. Modifications to closed bodies
4. Implementations of special bodies
5. Technical data
6. Weights (masses)
7. Notes on homologation of modifications and conversions
8. Listings

#### Information

For more information, see chapter 1.2.1.1 “Contact”, and chapter 1.2.2 “Body builder guidelines and consulting”.

It is essential that the limit values selected in chapter 2 “Technical data for planning” are complied with and are used as the basis for planning.

### 1.1.2 Means of representation

The following means of representation are used in these body builder guidelines:

#### Warning note

A danger note draws your attention to possible accident or injury risks to which you or other persons might be exposed.

#### Environmental note

An environmental note provides you with information about environmental protection.

#### Practical note

This note draws your attention to the risk of possible damage to the vehicle, as well as to regulations and provisions to be observed.

#### Information

This note indicates additional information.

### 1.1.3 Vehicle safety

#### Warning note

Before installing external add-ons or mechanical units, it is essential that you read the chapters in these body builder guidelines that are related to installation, as well as corresponding chapters in the instructions and information for the suppliers' mechanical units and in the detailed owner's manual for the base vehicle. Otherwise you will not be able to recognise dangers, and might expose yourself or others to danger.

We recommend that you use parts, mechanical units, conversion parts or accessories that have been tested by Volkswagen AG for the corresponding vehicle type.

Have the vehicle's safety checked immediately if non-recommended parts, mechanical units, conversion parts or accessories are used.

#### Practical note

It is essential that you comply with European vehicle approval or UN ECE R regulations, as well as national registration regulations and also technical vehicle regulations. This is because body activities on the vehicle can alter the vehicle type under registration regulations and the operating permit may be invalidated.

This applies in particular to:

- modifications which change the vehicle type approved in the operating permit
- modifications which might be expected to endanger road users or
- modifications which impair the exhaust or noise emissions characteristics.

### 1.1.4 Operational safety

#### Warning note

Incorrect interventions in electronic components and their software may result in these no longer functioning. Due to the networking of electronics, systems that were not modified can be affected.

Malfunctions to the electronics can significantly impair the operational safety of the vehicle.

Have work on or modifications to electronic components performed by a qualified specialist workshop which has the necessary specialist knowledge and tools for performing the necessary work.

Volkswagen AG recommends a Volkswagen AG customer service workshop for this purpose.

Service by a qualified specialist workshop is essential, in particular for safety-relevant work and work on safety-relevant systems.

Some safety systems only operate when the engine is running. Therefore, do not switch the engine off when driving.

### 1.1.5 Note on copyright

The texts, pictures and data contained in these body builder guidelines are subject to copyright. This also applies to editions on CD-ROM, DVD or other media.



## 1.2 General notes

The following pages contain technical guidelines for body builders and equipment fitters on the design and assembly of bodies. The body builder guidelines must be strictly adhered to when performing any modifications to the vehicle. The current version of the German edition of the body builder guidelines is the exclusive authority for the most up-to-date information.

This also applies to legal claims. Should the body builder guidelines include references to legal regulations, then no guarantee can be provided for the completeness and correctness of this content, or that it is up-to-date. Country-specific features can vary.

### 1.2.1 Product and vehicle information for body builders

#### 1.2.1.1 Contact in Germany

If you have questions concerning vehicle models from Volkswagen Commercial Vehicles, you can contact us via the internet portals of Volkswagen AG ([www.customized-solution.com](http://www.customized-solution.com)) or via one of the following methods:

<b>Free hotline (from a German landline)</b>	00 800-2878 66 49 33 (00 800-CUSTOMIZED)
<b>Contact (email)</b>	<a href="mailto:customizedsolution@volkswagen.de">customizedsolution@volkswagen.de</a>
<b>Personal contacts</b>	<a href="https://www.customized-solution.com/de/de/service-informationen/kundenbetreuung">https://www.customized-solution.com/de/de/service-informationen/kundenbetreuung</a>

#### 1.2.1.2 International contact

Please contact the body builder's support personnel at the responsible importer for technical advice relating to Volkswagen Commercial Vehicles models and as a point of contact for conversions.

To find the contact person responsible for you, please register on the Volkswagen AG CustomizedSolution portal (<https://www.customized-solution.com>).

Help is available for the registration option using the "Help" menu option.

<b>International hotline</b>	00-800-2878 66 49 33 (00-800-CUSTOMIZED)
<b>Email</b>	<a href="mailto:customizedsolution@volkswagen.de">customizedsolution@volkswagen.de</a>
<b>Personal contacts</b>	<a href="https://www.customized-solution.com/de/de/service-informationen/kundenbetreuung">https://www.customized-solution.com/de/de/service-informationen/kundenbetreuung</a>

#### 1.2.1.3 Electronic repair and workshop information from Volkswagen AG (erWin\*)

Body builders can access repair and workshop information, e.g.

- Current flow diagrams
- Workshop manuals
- Maintenance
- Self-study Programmes

via the Electronic Repair and Workshop Information System from Volkswagen AG (erWin\*).

<http://erwin.volkswagen.de/erwin/showHome.do>

Body builders with Integrated or PremiumPartner status are eligible for discounted annual licences that can be requested in the CustomizedSolution Portal under My CustomizedSolution Portal/Requirements/Planning and Development.

Body builders in export with the Partner status receive information in this regard from their point of contact at the importer.

\*Information system, subject to payment

#### 1.2.1.4 Genuine Parts Online Ordering Portal\*

For the purchase of spare parts and for the research of Volkswagen Genuine Parts, our latest parts catalogues are available on the Internet in the “Genuine Parts Online Ordering Portal”:

<http://www.partslink24.com>

\*Information system, subject to payment

#### 1.2.1.5 Online Owner’s Manual

Detailed information about the functions and handling of your vehicle can be found in your Owner’s Manual which is enclosed with your vehicle ex-works. In addition to the hard copy of the Owner’s Manual, the following link and VIN number of the vehicle can be used to receive the Owner’s Manual in electronic form.

[https://userguide.volkswagen.de/public/vin/login/de\\_DE](https://userguide.volkswagen.de/public/vin/login/de_DE)

#### 1.2.1.6 European Type Approval (ETA) and EC Certificate of Conformity (CoC)

Directive (EU) 2018/858 of the European Parliament establishes the standard for the approval of motor vehicles and their trailers, and of systems, components and separate technical units intended for such vehicles.

Provisions were also adopted in these guidelines for the approval of vehicles produced in several stages: the multi-stage approval process. Accordingly, each manufacturer involved in the construction of a vehicle is itself responsible for the approval of modified or added scopes in its production stage.

The manufacturer may choose one of the four following methods:

- EU type approval (ETA)
- EU type approval for small series
- National small series type approval
- Individual approval

CoC = Certificate of Conformity. A document that verifies the conformity of certain goods – and therefore also of vehicles and bodies – in accordance with the recognised (international) standards. The purpose of this EC Certificate of Conformity is to facilitate the approval of goods on international markets. As a result, the document is needed above all in import and export as part of the customs clearance procedure.

The manufacturer, the owner of an EU type approval or EU small series type approval, is obliged to provide a Certificate of Conformity with every vehicle which corresponds to an approved type. If you are planning to apply multi-stage type approval, an agreement must be concluded in accordance with the 2018/858/EU regulation.

### 1.2.1.7 Worldwide Harmonised Light Vehicles Test Procedure (WLTP)

New consumption values/ranges calculated in accordance with the new WLTP standards apply from September 2017 for new passenger cars entering the market and from September 2018 for new light commercial vehicles entering the market.

As of 1 September 2018, certified WLTP measurements must be available for all newly registered passenger cars. The rule enters into force for larger light commercial vehicles one year later on 1 September 2019. 28+6 markets in Europe are affected by the WLTP.

WLTP stands for Worldwide Harmonised Light Vehicles Test Procedure. This is a worldwide standardised testing procedure for determining fuel consumption / electric range and exhaust emissions.

It is replacing the NEDC (New European Driving Cycle) test procedure that has been in force since 1992.

Unlike the NEDC, the WLTP takes into account individual special equipment and conversion solutions for weight, aerodynamics, electrical system requirements (no-load current) and rolling resistance which have an impact on the fuel consumption / electric range and exhaust emissions. This includes, in particular, changes that result in a larger end face, a different radiator inflow area, a higher kerb weight for the vehicle or changes to the tyre size or the rolling resistance. Special equipment that consumes power, such as the air conditioning system or seat heating, still remains switched off for the duration of the test procedure.

Before initial approval, conversions or add-ons where WLTP is relevant can be made if they are approved by way of an individual approval or multi-stage type approval.

The Volkswagen type approval can be used for the multi-stage type approval for vehicles with conversions or add-ons that remain within the ISC parameters / maximum technical specifications for add-on parts. If the add-on or conversion is outside the ISC parameters / maximum technical specifications defined by the manufacturer for add-on parts, the body builder must demonstrate compliance with the exhaust gas emissions requirements / electric range.

Information about the ISC parameters / maximum technical specifications for add-on parts can be found on the Volkswagen CustomizedSolution portal. Please ask your technical service/test centre for advice if you have questions about alternatives.

To determine the consumption values of converted new vehicles in compliance with the WLTP procedure and to obtain a WLTP certification, the "WLTP Conversion Calculator" is available to you.

You can find more information as a Registered Converter on the CustomizedSolution portal / WLTP:

Germany / International: <https://www.customized-solution.com>

### 1.2.1.8 WLTP homologation for upgrades/conversions

For information on this topic, see chapter 7

### 1.2.1.9 Manufacturer's declaration

We issue a manufacturer's declaration for the base vehicle for the following scopes:

- Electromagnetic compatibility (EMC)
- Dangerous goods transport ADR 2017 for vehicles EX/II (explosive substances)

Please contact our customer support:

[nutzfahrzeuge@volkswagen.de](mailto:nutzfahrzeuge@volkswagen.de)

### 1.2.2 Body builder guidelines, consulting

The body assembly guidelines define the requirements for body builders and coachwork specialists for construction and assembly of custom body-related parts and conversions for Volkswagen Commercial Vehicles.

The body builder guidelines must be strictly adhered to when performing any modifications to the vehicle.

The statutory requirements, technical vehicle regulations and guidelines stated in the Directive are not comprehensive. When making modifications to vehicles, all applicable statutory requirements and all technical vehicle regulations and guidelines must be observed. The work safety regulations of the trade association and the Machinery Directive must be observed.

Ensure that no modification adversely affects the functional reliability and safety of the running gear, the body or the electric system. Modifications must only be performed by qualified specialists and in accordance with the generally acknowledged rules of the automotive industry.

Prerequisites for modifications to used vehicles:

The vehicle shall be in a good overall condition, i.e. structural parts such as longitudinal and cross members, pillars etc. shall not be corroded to such an extent that structural stability might be adversely affected.

Vehicles whose modifications might affect the validity of the general certificate of roadworthiness must be presented to an authorised testing centre for approval. It is recommended to clarify in advance with the relevant authority whether approval is required. Please contact us in case of inquiries for proposed modifications.

When inquiring about planned modifications, please enclose two sets of design drawings of the complete scope of the modification, including weights, centre of gravity and dimensions, which also clearly show how the body is attached to the chassis.

Please also provide information about the intended operating conditions of the vehicle.

If bodies comply with the present body builder guidelines, no additional approval by Volkswagen AG is required for the presentation of the vehicle at the relevant authority examining roadworthiness.

#### 1.2.2.1 Letter of non-objection

Volkswagen AG does not issue body approvals for non-Volkswagen bodies. It merely provides body builders with important information and technical specifications for dealing with the product in these guidelines. As a result, Volkswagen AG recommends that all work should be carried out on the base vehicle and the body in accordance with the current Volkswagen body builder guidelines applicable to the vehicle in question.

Volkswagen AG does not recommend body activities which

- are not conducted according to these Volkswagen body builder guidelines
- exceed the gross vehicle weight rating
- exceed the gross axle weight rating.

Volkswagen AG issues letters of non-objection on a voluntary basis, as follows:

The assessment conducted by Volkswagen AG is exclusively based on the documents submitted by the body builder which is carrying out the modifications. Only the expressly designated scopes are tested and ensured and essentially compatible.

The safety certificate relates to the presented overall vehicle, and not

- to the design of the overall body,
- its functions or
- the planned use.

Safety is only provided if the design, production and installation are carried out by the body builder performing the modifications in accordance with the state of the art and in accordance with the applicable body builder guidelines of Volkswagen AG – and assuming any deviations from these guidelines have been declared to be technically safe. The letter of non-objection does not release the body builder who is performing the modifications from its responsibility for the product, or from its obligation to carry out its own calculations, tests and a trial of the entire vehicle in order to ensure that the operational safety, road safety and driving properties of the overall vehicle it has manufactured are acceptable. Accordingly, it is necessary to ensure that the body builder exclusively accepts its responsibility for ensuring that its body activities are compatible with the base vehicle as well as the operational and road safety of the vehicle. It is expressly stated that the letter of non-objection from Volkswagen AG does not represent a technical approval for the investigated changes.

In the course of assessment of a presented vehicle, an assessment report is written as a means of obtaining a letter of non-objection (LONO report).

The following assessment results are possible:

- Classified as “safe”  
If the overall vehicle is classified as “safe”, the Sales department can subsequently issue the LONO certificate.
- Classified as “not safe”  
Classification as “not safe” in the individual categories:
  - + base vehicle configuration
  - + impairment of the base vehicle and possibly
  - + sole body item

leads to a corresponding classification of the overall vehicle. This means no LONO certificate can be issued initially.

In order for a not-safe classification to be resolved, the safety certificate report states the necessary change for each item in question. In order for the letter of non-objection to be obtained, these points will have to be addressed by the body builder and documented in a clearly comprehensible manner in a report along the same lines as the LONO report. On the basis of this detailed report, it is possible for the desk-review assessment to be completed with a positive result.

Depending on the defective points, it may be necessary not only to provide documentation of the defect resolution but also for the vehicle from the first inspection to be presented again. The first report indicates if it will be necessary for a new assessment to be carried out on the vehicle.

The assessment report may also contain “notes/recommendations”.

Notes/recommendations are technical remarks which do not have any effect on the letter of non-objection. They should be regarded as advice and suggestions for further consideration to support the continuous improvement of the final product for the customer.

In addition, notes/recommendations “solely relating to the conversion” can also be formulated. The notes and recommendations stated as “solely relating to the body/conversion” must be dealt with and documented before the vehicle can be presented in the CustomizedSolutionPortal.

#### Practical note

Country-specific laws, directives and approval regulations shall be observed!

### 1.2.2.2 Application for the letter of non-objection

Before starting any work on the vehicle, verifiable technical documentation and drawings must be submitted to the responsible department (see chapters 1.2.1.1 “Contact in Germany” and 1.2.1.2 “International contact”) as part of the letter of non-objection evaluation.

Speedy handling of the request requires:

- Documents preferably in standardised digital formats (e.g. PDF, DXF, STEP)
- Technical data and documentation should be complete

The following details must be included:

- Vehicle type
- + Vehicle design (Multivan)
- + Wheelbase
- + Frame overhang
- Vehicle identification number (if already available)
- Any deviations from these body builder guidelines must be indicated on all documentation
- Axle load calculation
- All data about dimensions, weight and centre of gravity (weighing certificate)
- Special operating conditions (e.g. poor road conditions, extreme dust, high altitude, or ambient temperature extremes)
- Certificates (e-registration, seat tensile test)
- Attachment of the body on the vehicle
- Type of fixation for the body or add-ons to the vehicle frame (e.g. bolted connections)
- + Positioning
- + Type
- + Size
- + Number
- + Property class
- Type of fixation for the body or add-ons to the vehicle frame (bolting, bonding, welding)
- Photographic documentation of the conversion
- All documents must clearly correlate with the conversion (e.g. drawings marked with allocated numbers).
- General (functional) description of deviations from the series vehicle, or added components.
- Electric wiring diagram
- + Details of the consumption of additional electrical equipment.

Complete documentation avoids the need for clarification queries and accelerates the processing.

### 1.2.2.3 Legal entitlements

- There is no legal entitlement for a letter of non-objection to be issued.
- Due to ongoing technical development and the information derived from this, Volkswagen AG is entitled to refuse a letter of non-objection even if a comparable certificate had been issued formerly.
- The letter of non-objection can be restricted to individual vehicles.
- The subsequent issue of a letter of non-objection may be refused for vehicles that have already been completed or delivered.
- The body builder is solely responsible for:
  - + the function and compatibility of its body activities with the base vehicle.
  - + road safety and operational reliability.
  - + all body activities and installed parts.

### 1.2.3 Warranty and product liability of the body builder

UN ECE Regulation No. 155 for vehicle cyber security and UN ECE Regulation No. 156 for vehicle software updates apply to all new vehicle types from the middle of 2022 and to all new vehicle registrations from the middle of 2024; these contain new requirements for automotive cyber security and updates.

Insofar as modifications are made to the vehicle, the body builder shall also ensure that these regulations are applied and complied with. The body builder's or equipment fitter's warranty conditions apply to the body builder's or equipment fitter's scope of supply. Therefore, warranty claims associated with complaints to this scope of supply cannot be made under the warranty conditions applicable to Volkswagen Commercial Vehicles.

Defects of bodies, installations and conversions provided by third parties as well as defects of the vehicle caused by the said bodies, installations or conversions are excluded from the Volkswagen warranty and also from the Volkswagen paint and body warranty. This also applies to accessories which were not installed and/or supplied by the vehicle manufacturer.

The body builder or equipment fitter is solely responsible for the design and assembly of bodies and the execution of conversions.

All modifications must be documented by the body builder or equipment fitter.

The body builder is responsible for ensuring that all modifications it performs comply with the technical vehicle regulations, specifications and standards that apply in the countries of registration.

Due to the multitude of modifications and diversity of operating conditions, the information provided by Volkswagen AG is subject to the reservation that modified vehicles are not tested by Volkswagen AG. Modifications may affect the properties of the vehicle.

For reasons of liability, the body builders or fitters must provide the following information in writing to their customers:

“Due to the modifications\* to your Volkswagen Commercial Vehicles base vehicle, the properties of your base vehicle may have changed. Please understand that Volkswagen AG does not assume any liability for any negative effects resulting from the modifications\* to the vehicle.”

In individual cases, Volkswagen AG reserves the right to demand evidence of the information being passed on to the customer.

No general legal entitlement for the approval of a body modification exists, even if such approval was previously granted.

If bodies comply with the present guidelines, no additional approval by Volkswagen AG is required for the presentation of the vehicle at the relevant authority examining roadworthiness.

\* At this point, the term “modification” may be substituted by a more precise description of the work performed, e.g. by “camping equipment installation” or “wheelbase extension”.

### 1.2.4 Ensuring traceability

Body dangers only detected after delivery can mean that subsequent measures in the market will be necessary (customer information, warning, call-back). To make these measures as efficient as possible, it is necessary to be able to trace the product after delivery. For this purpose, and in order to be able to use the central vehicle register (CVR) operated by the Federal Motor Transport Authority or comparable registers abroad for tracing the affected vehicle keepers, we strongly recommend that body builders should store the serial number / identification number of their body linked to the vehicle identification number of the base vehicle in their databases. For this purpose, it is also recommended that customers' addresses are stored and that subsequent owners are provided with a means of registration.

### 1.2.5 Trademarks

VW badges and VW emblems are trademarks of Volkswagen AG. VW badges and VW emblems are not allowed to be removed without authorisation, or to be attached in a different location.

#### 1.2.5.1 Positions on rear of the vehicle

VW badges and VW emblems which are enclosed in the delivery must be fitted in the location intended by Volkswagen.

#### 1.2.5.2 Appearance of overall vehicle

If the vehicle does not correspond to the appearance and the quality requirements set by Volkswagen AG, then Volkswagen AG reserves the right to request removal of the Volkswagen AG trademarks.

#### 1.2.5.3 Non-Volkswagen trademarks

Non-Volkswagen badges are not allowed to be attached next to Volkswagen badges.

### 1.2.6 Recommendations for vehicle storage

Extended storage times cannot always be avoided. The following measures are recommended to ensure that vehicle quality is not affected by long-term storage:

At vehicle delivery:

- Open all ventilation flaps, set blower to maximum speed.
- Put manual gearbox into 1st gear or lever of automatic gearbox into park position. Do not engage reverse gear. Do not apply the parking brake.

Check the battery open-circuit voltage (depending on the vehicle equipment):

Battery open-circuit voltage	Reading/measure
<10% or <11.6 V	Battery defective/totally discharged/ fully charge battery immediately
10% to 80% or 11.6 to <12.5 V	Battery not able to start/ fully charge battery immediately
≥80% or ≥12.5 V	Battery voltage OK.

A maximum charging voltage of 14.8 volts must not be exceeded.



## After delivery of vehicle:

- Check weekly for aggressive deposits (e.g. bird droppings, industrial deposits) and clean if necessary.
- Brake clean the brake discs every three months.
- Check tyre pressure at least once a month. The tyre pressure sticker states the correct tyre pressure for tyres fitted at the factory. The information applies to summer tyres, all-season tyres and winter tyres. The tyre pressure sticker is located either on the driver seat console or on the inside of the tank flap (see chapter 1.2.1.5 “Online owner’s manuals”).
- Check the battery open-circuit voltage in accordance with the maintenance cycle (in accordance with the information above):
  - + Every 6 weeks for vehicles without transport mode or
  - + Every 3 months for vehicles with transport mode or
  - + Every 6 months if there is a permanently attached solar panel.

## Activate and deactivate transport mode:

Transport mode is a function of the vehicle to conserve the battery when the vehicle is delivered to the dealer. The mode is activated at the factory before delivery and is only used to transfer the vehicle from the production site to the dealer. When activated, certain power consumers such as the radio and central locking are switched off to conserve the battery.

Before the vehicle handover to the customer, the transport mode is deactivated again by the customer service workshop with the VAS tester.

**Practical note**

When recharging the battery, use only a current-controlled battery charger with voltage limiter and IU or IUoU characteristic and a minimum charge current of 10 amps. A maximum charging voltage of 14.8 volts must not be exceeded. The battery must always be charged for at least 24 hours. This does not apply when using a charger with a full-charge indicator.

When connecting the battery charger, the following connection specification must be observed under all circumstances:

- Positive: always connect to jump-start terminal, if fitted, otherwise to battery positive terminal
- Negative: always at the body earth provided for charging, as the direct connection of a battery charger to the negative terminal of the battery in some vehicles can lead to falsification of the battery status recording by the on-board electronics.

**Practical note**

Charging the battery when it is installed is recommended. Series and parallel charging of batteries is unauthorised.

## Information

You can find further information about vehicle storage in the following documents:

- Owner's Manual
- Vehicle care programme.

### 1.2.7 Compliance with environmental rules and regulations

#### Environmental note

The following principles of environmentally friendly design and material selection should be followed right from the planning stage of fitted components or bodies, and the statutory requirements in the EU Directive on End-of-Life Vehicles 2000/53/EC should also be taken into account.

The body builder is responsible for ensuring that all modifications it performs comply with the environmental regulations, specifications and standards that apply in the countries of registration and sale. These may go beyond the existing prerequisites of the base vehicle and are the responsibility of the body builder.

The body builder must ensure that attachments and add-on parts (conversions) comply with all applicable environmental rules and regulations, in particular but not exclusively EU directive 2000/53/EC concerning end-of-life vehicles and the REACH regulation (EC) 1907/2006 relating to restrictions on the marketing and use of certain dangerous substances and preparations (“low flammability” and certain flame-retardant agents).

The registered keeper must keep all assembly documentation concerning the modification and hand it over together with the vehicle to the dismantler. This ensures that modified vehicles are processed in compliance with environmental rules and regulations at the end of their life cycle.

Materials which represent a potential risk such as halogen additives, heavy metals, asbestos, CFCs and chlorinated hydrocarbons shall be avoided.

- EU Directive 2000/53/EC must be adhered to.
- Preferably, materials which allow valuable substance recycling and closed material cycles shall be used.
- The material and production process shall be selected so that only low amounts of easily recyclable waste are generated.
- Plastics shall only be used where these offer advantages in terms of cost, function or weight.
- In the case of plastics, especially composite materials, only mutually compatible substances from one material family may be used.
- With regard to components that are relevant for recycling, the number of plastic types used shall be kept as low as possible.
- It is necessary to check whether a component can be manufactured from recycled material or with recycled additives.
- Care shall be taken to ensure that recyclable components can be removed easily, e.g. by means of snap-lock connections, predetermined breaking points, good accessibility, use of standard tools.
- Simple, environmentally friendly removal of the fluids shall be ensured by means of drain plugs etc.
- Wherever possible, the components shall not be painted or coated; instead, dyed plastic parts shall be used.
- Components in areas at risk of accident shall be designed to be tolerant of damage, repairable and easy to exchange.
- All plastic parts shall be identified according to the VDA material sheet 260 (“Components of motor vehicles; Identification of materials”), e.g. “PP-GF30R”.

### 1.2.8 Recommendations for inspection, maintenance and repair

A service schedule outlining inspection and servicing work must be provided for the modifications performed by the body builder or accessories fitter. These instructions or schedules must include the maintenance and inspection intervals as well as the required operating fluids and materials and the spare parts. It is also important to specify parts and components with a limited service life which are to be checked at regular intervals in order to ensure service reliability and timely replacement where required.

This should be supported by a repair manual including tightening torques, settings and tolerances as well as other relevant specifications. Special tools, including their source of supply, must also be stated.

Body builders / fitters must also state which work may only be performed only by themselves or by their authorised workshops.

If the body builder's or accessory fitter's scope of supply includes electric, electronic, mechatronic, hydraulic or pneumatic systems, then current flow diagrams and diagnosis routines or similar documentation facilitating a systematic search for faults should be provided.

Please observe the Volkswagen AG owner's manual for the inspection, maintenance and repair of the base vehicle.

Please observe the Volkswagen AG owner's manual for the inspection, maintenance and repair of the base vehicle. Please only use brake fluids and engine oils approved by Volkswagen for your vehicle.

More detailed information on brake fluids and engine oils can be found in the Owner's Manual for your vehicle (see also chapter 1.2.1.5 "Online Owner's Manual").

### 1.2.9 Accident prevention

Body builders shall ensure that the bodies comply with applicable legal rules and regulations as well as all regulations regarding work safety and accident prevention. All safety rules and the information material provided by accident insurance providers shall be observed.

All technically feasible measures must be taken to prevent unsafe operation.

Country-specific laws, directives and approval regulations must be observed.

The body builder is responsible for the compliance with these laws, rules and regulations.

For further information about commercial freight traffic in the Federal Republic of Germany please contact:

<b>P.O. box address</b>	Berufsgenossenschaft für Fahrzeughaltungen Fachausschuss "Verkehr" Sachgebiet "Fahrzeuge" Ottenser Hauptstrasse 54 D-22765 Hamburg
<b>Telephone</b>	+49 (0) 40 39 80 - 0
<b>Fax</b>	+49 (0) 40 39 80-19 99
<b>Email</b>	<a href="mailto:info@bgf.de">info@bgf.de</a>
<b>Home page</b>	<a href="http://www.bgf.de">http://www.bgf.de</a>

### 1.2.10 Quality system

Worldwide competition, increased quality requirements placed on the overall Transporter product by customers, national and international product liability legislation, new forms of organisation and increasing pressure on costs mean that effective quality assurance systems are demanded in all areas of the automotive industry. The requirements of a quality management system of this kind are described in DIN EN ISO 9001.

For the reasons stated above, Volkswagen AG strongly recommends that all body builders should set up and maintain a quality management system with the following minimum requirements:

Definition of responsibilities and authorisations including organisational plan.

- Description of the processes and procedures.
- Appointment of a quality management representative.
- Performing contract and build feasibility checks.
- Performing product checks based on specified instructions.
- Regulating the handling of faulty products.
- Documentation and archiving of test results.
- Ensuring the quality records of employees are up to date.
- Systematic monitoring of test equipment.
- Systematic material and parts identification.
- Performing quality assurance measures at the suppliers.
- Ensuring the availability of process, working and test instructions, and that they are up to date, in the departments and in the workplace.

## 1.3 Planning bodies

### Practical note

In addition to a user and maintenance friendly design (see chapter 2.3.2.10 “Corrosion protection measures”), the right choice of materials and therefore observance of corrosion protection measures are important during the planning of bodies.

### 1.3.1 Selecting the base vehicle

The base vehicle needs to be selected carefully to ensure safe usage in the respective field.

When planning, please consider the following for the use in question:

- Wheelbase
- Engine/gearbox
- Final drive ratio
- Gross vehicle weight rating
- Seating version (number and arrangement)
- Electrics scopes (e.g. interior lighting, battery, e-interface for special vehicles, customer-specific functional control unit (CFCU\*)). See chapter 2.5 “Electrics/electronics”.

### Practical note

Before carrying out body building or conversion measures, the supplied base vehicle should be checked with regard to the fulfilment of applicable requirements.

Please choose the appropriate electrical interface for the planned use of the vehicle.

See chapter 2.5.3 “Electrical interface for special vehicles”.

\*CFCU: customer-specific functional control unit, see also chapter 2.5.3.3.

You will find more information on the available Multivan versions and body versions in the sales documentation.

Please contact us (see chapters 1.2.1.1 “Contact in Germany” and 1.2.1.2 “International contact”).

### Information

On the Volkswagen AG homepage, you can put together your vehicle using the configurator and view the special equipment available:

<https://www.volkswagen-nutzfahrzeuge.de/de/modelle.html>

### 1.3.2 Vehicle modifications

Before starting work on the body, the body builder should check whether the vehicle is suitable for the planned body.

Build dimension drawings, product information and technical data can be obtained from the relevant department or via the communication system for the planning of bodies (see chapter 1.2.1.1 “Contact in Germany”, 1.2.1.2 “International contact” and 1.2.2 “Body builder guidelines, consulting”).

Furthermore, the special equipment available from the factory should be noted (see chapter 1.4 “Special equipment”).

Vehicles delivered from the factory comply with European directives and the national laws (except for some vehicles for countries outside Europe).

The vehicles also need to meet the European directives and the national laws after the modifications have been made.

#### Information

Please note that a majority of the EC directives announced to date have been annulled by Regulation (EC) 661/2009 “General Safety”. The EC directives have been replaced by new EU directives or UNECE regulations with the same corresponding content.

#### Practical note

Sufficient space must be provided in order to guarantee the function and operating safety of the components.

#### Warning note

Do not modify the steering or brake system! Modifications to the steering and brake system can result in these systems no longer working correctly and failing. This may result in the driver losing control of the vehicle and causing an accident.

#### Practical note

Modifications to the noise encapsulation can have effects which are relevant to registration.

### 1.3.3 Vehicle acceptance

The officially recognised appraiser or tester from the body builder must be informed about modifications to the vehicle.

#### Practical note

Country-specific laws, directives and approval regulations shall be observed!



## 1.4 Optional equipment

We recommend using the special equipment from Volkswagen AG that can be obtained with a PR number for optimum adaptation of the body to the vehicle.

You can obtain information on special equipment provided by Volkswagen under PR numbers from your authorised repairer or from your available contacts for product and vehicle information for body builders (see chapters 1.2.1.1 “Contact in Germany” and 1.2.1.2 “International contact”). Please also note chapter 5 “Implementation of special bodies”.

### Information

You can also put your vehicle together with the configurator on the Volkswagen AG homepage and look at the available special equipment: <https://www.volkswagen-nutzfahrzeuge.de/de/modelle.html>

Special equipment (e.g. reinforced springs, frame reinforcements, anti-roll bars etc.) or equipment fitted later increase the kerb weight of the vehicle.

The actual vehicle weight and the axle loads should be determined and documented by weighing before and after the conversion. Not all additional equipment can be installed into every vehicle without problems. This applies in particular if it is fitted later on.

## 2 Technical data for planning

### 2.1 Base vehicle

#### 2.1.1 Vehicle dimensions

##### 2.1.1.1 Multivan basic data

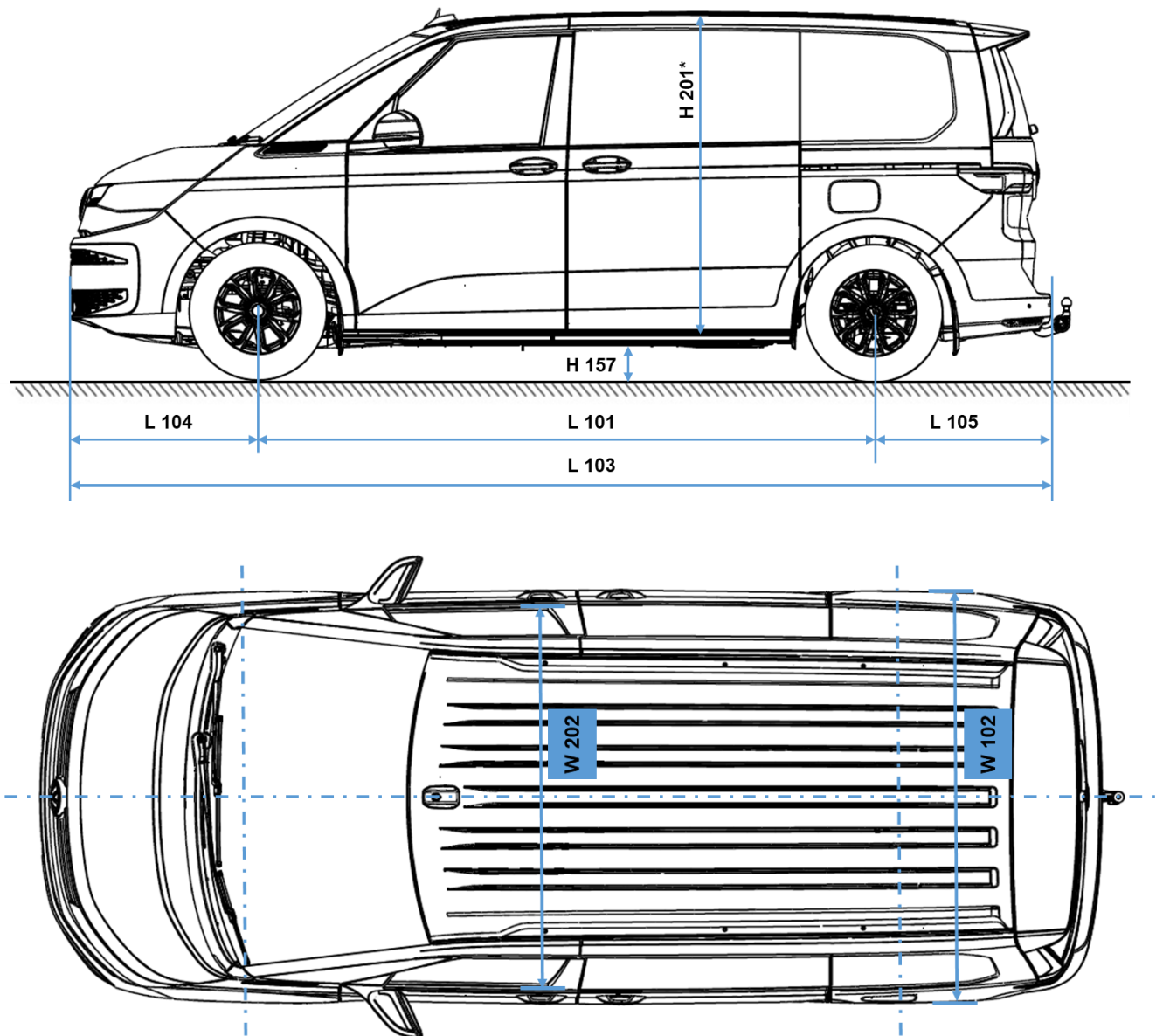

Fig. 1: Example vehicle dimensions of short + long Multivan (acc. to DIN 70020, P1)

\* The roof heights can be found in the basic data table under the term H201.

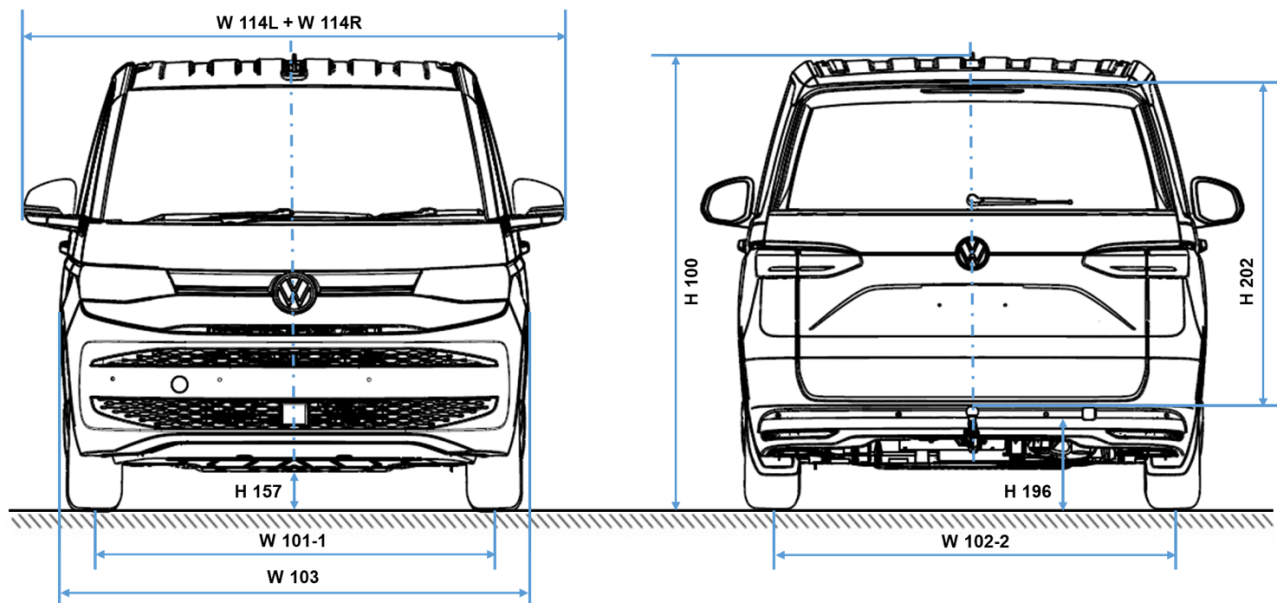

Fig. 2: Example vehicle dimensions of short + long Multivan (acc. to DIN 70020, P1)

Multivan basic data (ML1**) (All engines)			Multivan [mm]	Multivan long [mm]
Dimensions	L101	Wheelbase	3124	3124
	L103	Vehicle length	4973	5173
	L102	Vehicle length with rigid towing bracket (removable ball coupling)	5076	5276
	L515	Centre of gravity position, load compartment, distance from front axle (FA), 3-seater	3661	3761
	W103	Vehicle width (measuring point: door handle)	1941	1941
	H100	Vehicle height body	1907	1907
		-> lowered	1887	1887
	L104	Front overhang length	952	952
	L105	Rear overhang length	897	1097
		Rear overhang length with towing bracket	1000	1200
	W101-1	Track at front -> for rim offset 60 / standard running gear -> for rim offset 58 / standard running gear -> for rim offset 60 / lowered -> for rim offset 58 / lowered	1659	1659
			1663	1663
			1664	1664
1669			1669	
W102-2	Track at rear -> for offset 60 / standard running gear -> for rim offset 58 / standard running gear -> for rim offset 60 / lowered -> for rim offset 58 / lowered	1659	1659	
		1663	1663	
		1664	1664	
		1669	1669	

Multivan basic data (ML1**) (All engines)			Multivan [mm]	Multivan long [mm]
	WX 1	Maximum rear axle width	1922	1922
	WX 2	Maximum front axle width	1918	1918
	H157	Ground clearance between axles acc. to 2007/46/EC	161	161
	A117	Breakover angle -> lowered	11.8°	11.8°
			10.8°	10.8°
A116-1	Front overhang angle at full load, limited by spoiler -> lowered	18°	18°	
		16.1°	16.1°	
Dimensions	A116-2	Rear ramp angle at full load, limited by bumper -> lowered	16.6°	13.2°
			16.3°	13.1°
Turning circle	D102	Minimum turning circle	12.1m	12.1m
Wheels/tyres		Basic tyres***	Smallest tyre 195/75 R16 xl 100H  Largest tyre 245/45 R19 xl 102 H	
Load compartment measurements	L202	Length of the loading platform (EC 1230/2012) not for M1 registration	1147	1347
	L212-1	Luggage compartment length 1st row of seats (without 2nd and 3rd row of seats)	2425	2625
		Luggage compartment floor length, 2nd row of seats (without 3rd row of seats)	1316	1516
		Luggage compartment length, 3rd row of seats	461	661
	F201-1	Load compartment area -> behind the front seats -> behind the 2nd row of seats	3.3 m <sup>2</sup>	3.5 m <sup>2</sup>
			1.7 m <sup>2</sup>	1.9 m <sup>2</sup>
	W200	Largest luggage compartment width -> without 2nd and 3rd row of seats -> behind 3rd row of seats	1665	1665
			1245	1245
	W202	Width between wheel housings	1207	1207
	H212	Height of the luggage compartment, minimum (with 2nd luggage compartment floor)	462	462
	H505	Loading height	1312	1312
	H196	Load sill height above ground level	580	583
H508	Clear opening height of sliding door	1173	1173	
L903	Clear opening width of sliding door	931	931	

Multivan basic data (ML1**)			Multivan	Multivan long
(All engines)			[mm]	[mm]
Load compartment measurements	H101-M	Maximum vehicle height	1907	1907
	H110	Vehicle height with rear lid open	2143	2146
	H202	Body opening height	1169	1169
	W206	Largest width of rear opening	1312	1312
Garage dimensions	W120-1	Vehicle width, front doors open	3804	3804
	W114-L	Y-coordinate of exterior mirror on driver side	1123	1123
	W114-R	Y-coordinate of exterior mirror on passenger side	1123	1123
Vehicle interior dimensions	H61-1	Effective headroom – 1st seat row	1024	1024
	H61-2	Effective headroom – 2nd seat row	1001	1001
	H61-3	Effective headroom – 3rd seat row	975	975

\* ML3 – measurement load, loaded

\*\* ML1 – measurement load, unloaded

\*\*\* The permitted tyre size varies depending on the engine and the gross vehicle weight rating.

### 2.1.2 Ramp angle and breakover angle

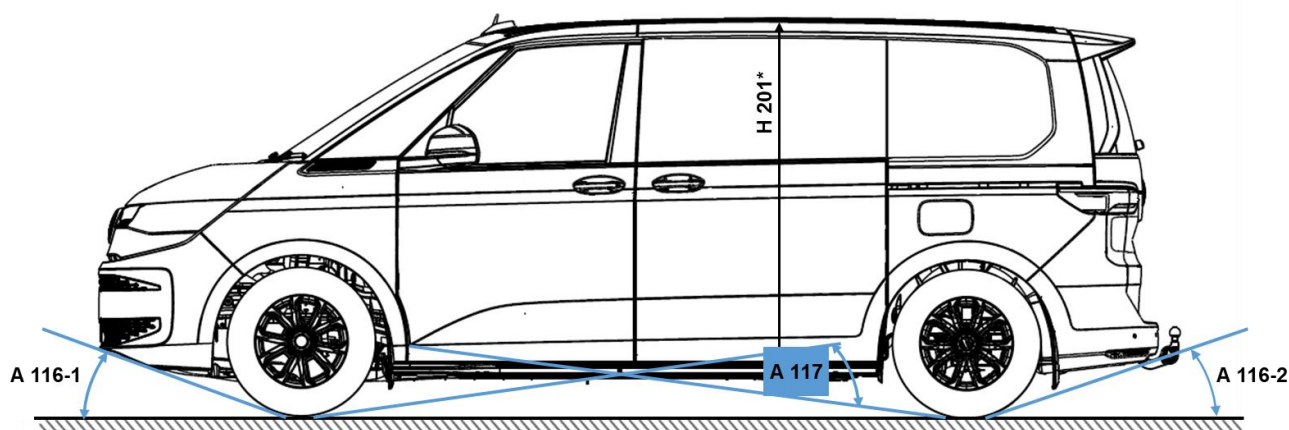

Fig. 1: Example vehicle dimensions of short + long Multivan (acc. to DIN 70020, P1)

The values for the overhang angle (A116) and the breakover angle (A117) can be found in the basic data table (see chapter 2.1.1.1).

## 2.2 Running gear

### 2.2.1 Permitted weights and unladen weights

#### Warning note

ATTENTION! Compliance with the maximum gross axle weight ratings specified in these body builder guidelines is required for conversions that lead to an increase in the base vehicle's axle weight rating (e.g. in the case of weight increases). If these values are exceeded, the durability of all components (and in particular the wheel hubs) must be checked and safeguarded using suitable measures.

Volkswagen AG offers the Multivan in the following weight classes: 2,600 kg, 2,750 kg and 2,850 kg.

#### Information

Load ratings depend on the engine. Equipment features can influence the payload or load weight by increasing/reducing the unladen weight. The weight values stated in the technical data refer to the standard, basic vehicle equipment. Weight tolerances of +5% in production are permitted in accordance with DIN 70020 and must be taken into account if necessary.

Installing special equipment reduces the payload.

The actual payload of a vehicle that is calculated from the difference between the gross vehicle weight rating and unladen weight can only be determined by weighing an individual vehicle.

### Practical note

For permanent installations, the running gear must be adjusted afterwards. Otherwise, it can lead to premature, uneven wear on the front axle tyres.

Once the customer has loaded the vehicle to a normal load level for its purposes, the running gear must be measured again in accordance with the workshop manual, based on the current height of the edge of the wheel housing.

For more information, refer to the Workshop Manuals from Volkswagen AG:

<http://erwin.volkswagen.de/erwin/showHome.do>

#### 2.2.2 Turning circle

See the basic data table (chapter 2.1.1 “Vehicle dimensions”).

#### 2.2.3 Authorised tyre sizes

The Volkswagen owner's manual provides information about the wheel/tyre combinations authorised by Volkswagen AG in conjunction with snow chains (see the table of basic data in chapter 2.1.1 “Vehicle dimensions”).

#### 2.2.4 Modifications to axles

Modifications to the axles are not permitted, because they can lead to an impairment in the driving properties and unstable driving behaviour.

#### 2.2.5 Modifications to the steering system

Modifications to the steering system are not permitted.

Exceptions, e.g. conversions for people with disabilities, shall be approved by Volkswagen AG prior to the conversion.

Please contact us before starting your conversion (see chapter 1.2.1.1 “Contact in Germany”,

1.2.1.2 “International contact”).

## 2.2.6 Brake system and brake control system ESC\*

### 2.2.6.1 General information

Changes to the brake system are not allowed under any circumstances:

- If the modification to the brake system goes beyond the scope of the operating permit.
- If the air inflow and outflow to and from disc brakes are modified.

#### Warning note

Work performed incorrectly on brake hoses, lines and cables may impair their function. This can lead to a failure of components or safety-relevant parts. Therefore, work on brake hoses, lines and cables should only be performed by a qualified specialist workshop.

\*Electronic Stability Control

### 2.2.6.2 Routing additional lines along the brake hoses/brake lines

No other additional lines are allowed to be fastened to brake hoses and brake lines.

Additional lines must remain at a sufficient distance from brake hoses and brake lines under all operating conditions, and are not allowed to touch or chafe against such brake hoses/lines under any circumstances (see chapter 2.5.2.1 “Electrical wiring/fuses”).

### 2.2.7 Modification of springs, suspension mounting, dampers

The spring rates are never allowed to be modified.

We recommend using optimally matching springs from the Volkswagen delivery range for the vehicle with body.

Modifications to the springs must be appraised and recorded by the applicable technical test centre / monitoring organisation / technical service. Modifications that are not recorded and registered can result in invalidation of the vehicle’s operating permit.

#### Practical note

We indicate that when the vehicle is converted to an air-sprung suspension system due to a change in the vibration behaviour of the wheels, this can lead to possible faulty displays of the factory-installed tyre pressure indicator (TPLI).

Please contact us before making any planned modifications to the running gear (see chapters 1.2.1.1 “Contact in Germany” and 1.2.1.2 “International contact”).

### 2.2.8 Wings and wheel housings

The required clearance for the wheels including snow chains must be complied with.

Please take note of the information in the build dimension drawing.



## 2.3 Body-in-white

### 2.3.1 Roof loads

#### 2.3.1.1 Dynamic roof loads

Vehicle type	Max. roof load
Vehicles with normal roof and two base carriers	100 kg
Vehicles with normal roof and an additional base carrier	100 kg

See chapter 2.7.1 “Roof carriers” regarding the fitting of roof carriers.

The limit value for the maximum centre of gravity position of the vehicle is not allowed to be exceeded.

#### 2.3.1.2 Static roof loads

The values in the table (see chapter 2.3.1.1 “Dynamic roof loads”) refer to permissible roof loads when the vehicle is moving.

When using a static roof load, the following applies:

A static roof load of up to 250 kg does not cause any damage to the vehicle if the loads are evenly distributed. The maximum roof load may only be used when the vehicle is stationary. Vehicle operation with the static roof load is expressly prohibited. All available connection points of the body for roof carrier systems in the roof area must be used.

Direct loading of the roof surface is not permitted. One-sided loads can cause damage to the roof.

Volkswagen AG offers no warranty for damage to the vehicle resulting from improper use.

### 2.3.2 Modifications to the body-in-white

Changes to the body are not allowed to impair the function and strength of units and operating devices of the vehicle, neither may they reduce the strength of weight-bearing parts.

During vehicle conversions and installation of bodies, it is not permitted to make any modifications which impair the function and freedom of movement of the suspension (e.g. for maintenance and inspection work) or the accessibility to the same.

#### 2.3.2.1 Screw connections

If series-production bolts / nuts have to be renewed, it is only permitted for bolts / nuts to be used which have the:

- same diameter.
- same strength.
- same bolt standard or bolt type.
- same surface coating (corrosion protection, coefficient of friction).
- same thread pitch.

Comply with VDI guideline 2862 during all installations.

Shortening the free clamping length, changing over to waisted shank and use of bolts with a shorter free thread proportion are not permitted.

Furthermore, take the settling behaviour of screw connections into account.

When attaching components to the base vehicle using screws, made sure that no panels or other components of the base vehicle are bent or damaged.

The use of Volkswagen tightening torques assumes that the total coefficient of friction is in the range  $\mu_{\text{tot}} = 0.08$  to  $0.14$  for the particular items being bolted together.

If bolts are tightened by torque and final tightening angle at Volkswagen, no change of design is possible.

#### **Risk of accident**

No safety-relevant bolted connections, e.g. for wheel guidance, steering and brake functions, may be modified. Otherwise the designated function may be impaired. This may result in the driver losing control of the vehicle and causing an accident. The new installation is to be carried out according to VW Customer Service instructions, using suitable standard parts. We recommend the use of Volkswagen genuine parts.

#### **Information**

Information about Volkswagen customer service instructions can be provided by any Volkswagen Customer Service.

### 2.3.2.2 Welding work

The following instructions must be observed before carrying out welding work on the body:

- Welding work should only be undertaken by people with appropriate qualifications.
- Before starting welding work, it is necessary to remove components which might contain gases representing a fire or explosion hazard, e.g. fuel system, or else to protect them with a fireproof cover against airborne sparks.
- Welding, soldering and thermal bonding or the use of hot air in the direct vicinity of the high-voltage components, the high-voltage wires and on the high-voltage battery are not permitted. If a sufficient distance cannot be maintained, the components must be removed. The information in the vehicle-specific repair instructions must be observed.
- Work on the high-voltage components may only be performed by qualified personnel
- For welding work near seat belts, airbag sensors or the airbag control unit, these components must be removed before work begins and for the duration of the work.
- Before starting welding work, cover the springs and spring bellows to protect them against weld spatter. Springs are not allowed to be touched with welding electrodes or welding tongs.
- No welding is allowed on mechanical units such as the engine, gearbox, axles.
- Remove and cover the battery positive and negative terminal clamps.
- Directly connect the earth clamp of the welding machine to the part to be welded. The earth clamp is not allowed to be connected to mechanical units such as the engine, gearbox, axles.
- The housings of electronic components (e.g. control units) and electrical wiring are not allowed to be touched with the welding electrode or earth clamp of the welding machine.
- The electrodes are only allowed to be used with direct current via the positive terminal for welding. Always weld from bottom towards the top.

#### Warning note

Incorrectly undertaken welding work can lead to a failure of safety-relevant components, and thus cause accidents.

#### Risk of injury

Welding in the area of the restraint systems (airbag or belts) can lead to these systems ceasing to function properly.

Welding in the area of child restraint systems is therefore prohibited.

#### Warning note

Special safety notes must be observed when working on electric vehicles. Failure to observe safety notes can result in a fatal electric shock.

### Warning note

The voltage within the high-voltage vehicle electrics and high-voltage battery is life-threatening!

Touching damaged orange-coloured high-voltage wires and high-voltage battery may result in a fatal electric shock. The high-voltage system may be active even if the ignition is switched off!

- Never carry out any work on the high-voltage vehicle electrics, orange-coloured high-voltage wires, high-voltage components or high-voltage battery. Work on the high-voltage system may only be performed by qualified specialist companies with appropriate accreditation to perform such work.
- Never modify, damage, dismantle or disconnect from the high-voltage system any of the orange-coloured high-voltage wires, high-voltage components or high-voltage battery.
- Work in the vicinity of high-voltage components, high-voltage wires and on the high-voltage battery may not be carried out until after de-energisation. The high-voltage battery **cannot** be de-energised. The high-voltage disconnection may only be performed by suitably qualified and trained specialist staff.
- If there is a fault in the high-voltage system, the drive is automatically deactivated where necessary, and a corresponding indicator may be displayed in the instrument cluster. Should this be the case, the drive will remain deactivated until the fault has been rectified by suitably qualified and trained specialist staff.
- The various Volkswagen policies must be observed when carrying out any work on the high-voltage vehicle electrics, including in particular on the orange-coloured high-voltage wires, high-voltage components or high-voltage battery.

**Practical note**

Disconnect the battery prior to starting welding work.  
Airbags, seatbelts, the airbag control unit and airbag sensors shall be protected against weld spatter, and removed if necessary.

**Information**

The required safety notes can be requested. Please contact us (see chapter 1.2.1 “Product and vehicle information for body builders”).

**2.3.2.3 Welded connections**

In order to achieve high-quality welds, the following basic recommendations are given:

- Thoroughly clean the areas to be welded.
- Apply several short weld beads, rather than one long one.
- Make symmetrical beads, in order to limit shrinkage.
- Avoid making more than three welds at any one point.
- Avoid welding in work-hardened areas.
- Spot welds and stitch welding should be offset.

**2.3.2.4 Selection of welding process**

The mechanical properties of welds depend on which welding process is selected, and on the geometry of the parts to be connected. If welding overlapping metal panels, the welding process depends on the accessibility of the sides:

Accessible sides	Welding process
1	Shielding gas hole spot welding
2	Spot welding

### 2.3.2.5 Spot welding

Spot welding is used for overlapping parts with access on both sides. Avoid spot welding of more than two layers of metal panels.

#### Distance between spot welds:

In order to avoid shunt effects, the specified distances between the spot welds must be maintained ( $d = 10e + 10 \text{ mm}$ ).

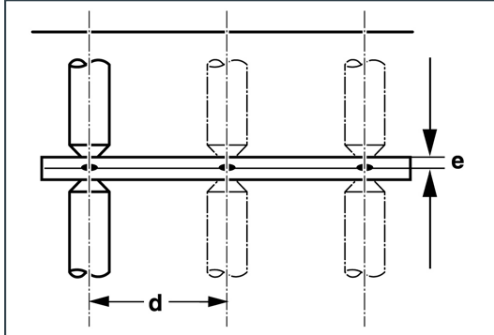

Ratio between panel thickness and distance between welds

d Distance between spot welds

e Panel thickness

#### Distance from the edge of the panel:

In order to avoid damage to the molten core, the specified distances from the edge of the panel must be maintained ( $L = 3e + 2 \text{ mm}$ ).

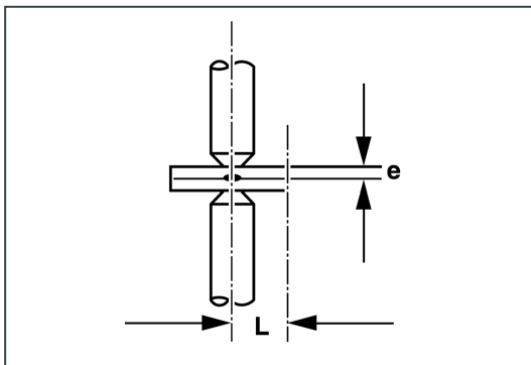

Ratio between panel thickness and distance from edge

e Panel thickness

L Distance from the edge of the panel

### 2.3.2.6 Shielding gas hole spot welding

If overlapping panels can only be welded on one side, it is possible to achieve the connection by protective gas hole spot welding or tacking. If the connection is achieved by punching or drilling and then hole spot welding, the drilling area must be deburred before welding.

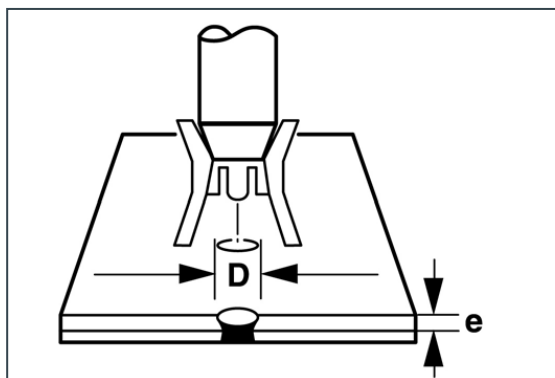

Ratio between panel thickness and hole diameter

D – hole diameter [mm]	4.5	5	5.5	6	6.5	7
e – panel thickness [mm]	0.6	0.7	1	1.25	1.5	2

The mechanical quality can additionally be improved by using slots ( $l = 2 \times b$ ).

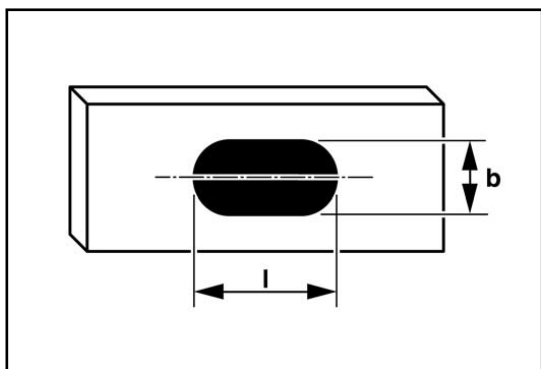

Ratio between width and length of slots

b Width of slot

l Length of slot

### 2.3.2.7 Tacking

If panels are >2 mm thick, overlapping panels can also be connected by tacking  
( $30 \text{ mm} < L < 40 \times e$ ;  $d > 2 L$ ).

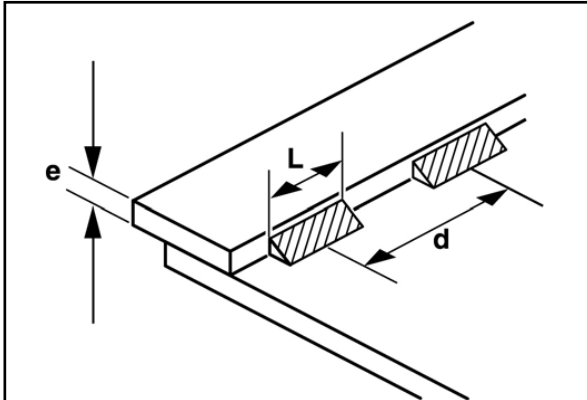

Ratio between panel thickness and distance between welds

d Distance between tack welds

e Panel thickness

L Length of tack weld

### 2.3.2.8 Welding is not allowed

Welding is not allowed:

- On mechanical units such as the engine, gearbox, axles etc.
- On the chassis frame except if there is a frame extension.
- On the A and B-pillars.
- On the upper and lower chords of the frame.
- In bend radii.
- In the area of airbags.
- Hole welding is only permitted in the vertical webs of the frame longitudinal member.

### 2.3.2.9 Corrosion protection after welding

After all welding work on the vehicle, it is necessary to comply with the specified corrosion protection measures  
(See chapter 2.3.2.10 “Corrosion protection measures”.)

### 2.3.2.10 Corrosion protection measures

Following conversion and installation work on the vehicle, surface and corrosion protection shall be applied to the affected points.

#### Practical note

Only the corrosion protection agents tested and approved by Volkswagen are allowed to be used for all corrosion protection measures.



### 2.3.2.11 Planning measures

Corrosion protection should be taken into account in the planning and design in the form of a suitable material selection and component design.

#### Information

If two different metallic materials are connected together by an electrolyte (e.g. moisture from the air) then this will give rise to a galvanic connection. The result will be electrochemical corrosion, and the less noble metal will suffer damage. The electrochemical corrosion will be all the greater the further apart the metals in question are in the electrochemical series.

Therefore, the components must have a suitable treatment or insulation applied to them in order to prevent electrochemical corrosion, or the corrosion must be kept at a low level by a suitable choice of materials.

#### Avoidance of contact corrosion by electrical insulation

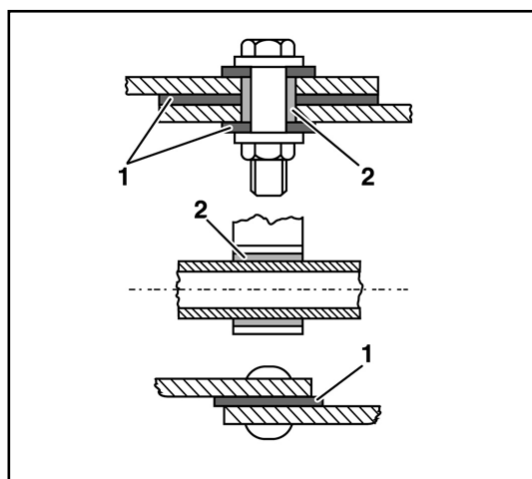

Avoidance of contact corrosion

1 Insulating washer

2 Insulating sleeve

Contact corrosion can be avoided by using electrical insulation such as washers, sleeves or tubes. Avoid welding work on inaccessible cavities.

### 2.3.2.12 Component design measures

Design measures, in particular in the design of connections between the same or different materials, can be used for providing corrosion protection:

Corners, edges, beads and folds represent locations where dirt and moisture can collect.

Suitable surfaces, drains and the avoidance of gaps at component connections represent means by which corrosion can be counteracted by design measures.

Gaps at welded connections as a feature of the design, and how to avoid them

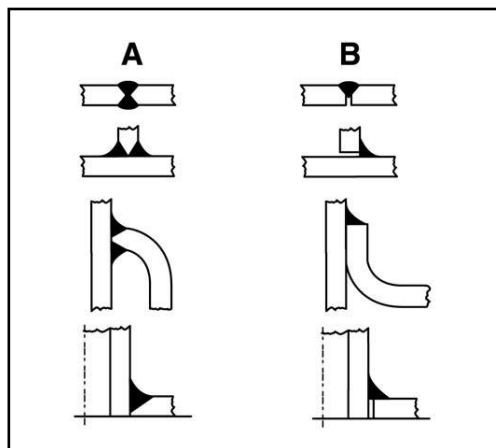

Application examples of welded connections

A = Favourable	B = Unfavourable
(through-welded)	(gap)

### 2.3.2.13 Coating measures

It is possible to protect the vehicle against corrosion by applying protective coatings (e.g. galvanizing, painting or high-temperature zinc application)

(See chapter 2.3.2.10 "Corrosion protection measures").

### 2.3.2.14 Work on the vehicle

After all work on the vehicle:

- Remove drilling chips.
- Deburr edges.
- Remove scorched paint and thoroughly prepare the surfaces for painting.
- Apply a primer to all bare metal parts, and paint them.
- Apply a wax-based corrosion protection agent to cavities.
- Carry out corrosion protection measures on the underbody and frame components.

## 2.4 Interior

### 2.4.1 Modifications in the area of airbags

Modifications on the airbag system and the belt tensioner system as well as on and in the area of airbag components, the airbag sensors and the airbag control unit are not permitted. Please also refer to chapter 4.1 “Vehicles for transporting persons with restricted mobility”.

The interior fittings shall be designed so that the airbag deployment areas are left unobstructed (see also chapter 3.1 “Interior”). For information about the deployment zones of the airbags, refer to the owner's manual of the vehicle.

#### Warning note

Modifications or incorrectly performed work on seatbelts and seatbelt anchor points, belt tensioners or airbags or their cabling could impair the correct function of these components. They might be activated inadvertently or fail in the event of an accident.

### 2.4.2 Modifications in the area of seats

The strength data for seats available ex-works is only valid in conjunction with the original attachment system.

#### Warning note

Only fit seat covers or protective covers that are expressly approved for use in the vehicle.  
The use of non-approved covers may prevent the side airbag from deploying.

#### Practical note

Modifications to the original series production condition can result in the withdrawal of type approval.  
Country-specific laws, directives and approval regulations shall be observed!

#### Information

You will find detailed information on torques etc. in the workshop manuals.  
Volkswagen AG workshop manuals and workshop information can be downloaded from the Internet at **erWin\*** (Electronic Repair and Workshop Information from Volkswagen AG):  
<http://erwin.volkswagen.de/erwin/showHome.do>

\*Information system from Volkswagen AG, subject to payment

#### 2.4.2.1 Belt anchors

The body builder is solely responsible for fitting additional belt points.

The necessary proof is to be provided by the body builder. Country-specific laws, directives and approval regulations shall be observed!

#### 2.4.3 Forced ventilation

Replacement measures must be created for vehicle modifications of any kind that can influence the standard forced ventilation.

This is important in several respects:

- Closing comfort of the doors
- Possible flow rate of the heating blower
- Pressure equalisation on airbag deployment

Ventilation slits must be installed in the partition wall in closed bodies with a partition wall.

In this case, make sure that the new forced ventilation cross sections are not smaller than the standard cross sections.

Air inlets and outlets are not allowed to be fitted in the immediate vicinity of sources of noise or exhaust gases.

#### 2.4.4 Acoustic insulation

During conversions, make sure that the noise level of interior noise is not changed. Noise insulating materials can be installed to reduce the noise level in the vehicle interior. This must be manufactured from flame-retardant materials.

#### 2.4.5 eCall Emergency System

In the event of an accident, the EU eCall Emergency System can help to reduce the time it takes until emergency services arrive at the scene. Data is transmitted to the emergency response coordination centre via the OCU communication model.

The emergency call therefore does not depend on a mobile telephone being ready for operation, but does require a mobile phone connection and the possibility of locating the vehicle via GPS or Galileo. It is triggered automatically by the crash sensors or manually by the driver using the SOS button. The emergency call automatically goes to the nearest emergency response coordination centre.

##### General conditions:

The ecall Emergency System consists of the following components:

- Communication module (OCU)
- Emergency call button
- Microphone
- Additional loudspeaker for telematics
- Aerials for mobile network
- Global satellite navigation system
- and their connections and cables.

As this is a certified system, no changes to components of the ecall Emergency System are permitted.

It should also be ensured in particular that the acoustic properties of the eCall Emergency System (emergency call loudspeakers and microphone) are not changed by constructional changes to the vehicle.

## 2.5 Electrics/electronics

Incorrect interventions in electronic components and their software may result in these no longer functioning as intended. Due to the networking of electronics, systems that were not modified can be affected. Malfunctions to the electronics can significantly impair the operational safety of your vehicle.

Work on or modifications to electronic components, in particular work on safety-relevant systems, is only allowed to be performed by a qualified specialist workshop, and by qualified specialist personnel who have the necessary specialist knowledge and tools for performing the necessary work.

Interventions in the vehicle electrical system/vehicle electronics can result in invalidation of the warranty/operating permit.

If modifications are made to the electrical system, take the vehicle to a VW workshop in order to delete the entries in the event memory at the completion of work. If a VAS tester is available, the event memory can also be deleted by trained personnel of the body builder.

### 2.5.1 Lighting

#### 2.5.1.1 Vehicle lighting devices

Comply with the country-specific registration provisions with regard to the complete lighting devices (lighting and turn indicator devices). Failing to comply can result in the operating permit being invalidated.

The headlights and tail light clusters are designed with LED technology as standard. The bulb failure monitor cannot be deactivated.

We recommend using Volkswagen Genuine tail light clusters or a product with E test symbol in LED technology.

Please note that in the completed (converted) vehicle, it is necessary to comply with the add-on regulations and dimensions of all technical lighting equipment acc. to UNECE Regulation UNECE-R 48.

Applicable accordingly to all vehicle types:

ECE Regulation:	Lighting equipment	Vehicle dimensions	Comment
UNECE-R 48, 6.12	Parking lights	Permitted for vehicle dimensions: Width*: $\leq 2,000$ mm and length: $\leq 6,000$ mm	The parking light is not prescribed. It is not permitted in longer and wider vehicles, and shall be deactivated if necessary.
UNECE-R 48, 6.13	End-outline marker lights	1) Only permitted for vehicles with a width: $\geq 1,800$ mm 2) Prescribed for vehicles with a width: $> 2,100$ mm	Applies to all Transporter models
UNECE-R48, 6.18	Side marker lights	Prescribed for vehicles with a length: $\geq 6,000$ mm	Permitted for other vehicles.
UNECE-R48, 6.5	Side turn signals Category 6	Prescribed for N1/M2 vehicles with length $> 6,000$ mm and N2 vehicles	Also permitted for other vehicles, any category 5 lights that are present should be taken out of service.
UNECE-R 48, Paragraph 6.7	3rd brake light		Since 1 November 2013, it is mandatory in Germany for M1 and N1 vehicles with a closed body!

\*Vehicle width measured after conversion without mirror

If a vehicle becomes longer than 6 m or wider than 2 m without mirrors due to the body, the parking light is not permitted.  
For these vehicles the parking light function must be decoded from the convenient control unit (onboard supply control unit (BCM)).

Category 5 side turn signals are installed on the Multivan (in the front wings).

These lights are only permitted for vehicles in class M<sub>1</sub> as well as for vehicles in class N<sub>1</sub> or M<sub>2</sub>, providing they are not more than six metres long.

This means the standard side turn signals are only sufficient for vehicles up to 3.5 t gross vehicle weight rating and up to 6 m in length.

### 2.5.1.2 Adjusting the headlights

The country-specific registration provisions apply.

The basic setting for the headlights must be put into effect and must be included in the configuration of the new construction status (e.g. fixed installations or add-on parts or changes to running gear components) of the vehicle.

It must be ensured that the adjustment range of the headlight range control complies with potential load levels.

For springs that deviate from the base vehicle and for settings for the headlight range control potentiometer (LWR Poti) that deviate from the vehicle wallet, these must be documented with regard to load levels, and must be attached to the vehicle wallet.

#### Information

More information about headlight settings can be found in the Volkswagen AG repair information/Maintenance Manual on the internet:  
<http://erwin.volkswagen.de/erwin/showHome.do>

\*Information system from Volkswagen AG, subject to payment

### 2.5.1.3 Special lights

#### 2.5.1.3.1 Rotating light, yellow light

Comply with the country-specific registration provisions when installing special lights.

Please also comply with the following chapters during the conversion:

- Chapter 2.2.1 “Permitted weights and unladen weights”
- Chapter 2.5.3 “Electrical interface for special vehicles”
- Chapter 2.5.4 “Vehicle battery”

#### 2.5.1.3.2 Roof-mounted turn signals

Comply with the country-specific registration provisions when installing special lights.

Please also comply with the following chapters during the conversion:

- Chapter 2.2.1 “Permitted weights and unladen weights”
- Chapter 2.5.3 “Electrical interface for special vehicles”
- Chapter 2.5.4 “Vehicle battery”

## 2.5.2 Vehicle electrical system

Please note:

For bodies and conversions with electromagnetic switching mechanisms (such as relays, magnetic switches, contactors and solenoid valves), these components must be equipped with integrated protective diodes (free-wheel diodes/anti-surge diodes), in order to exclude interference voltage peaks from the vehicle electrical system and the control units. If no protective diodes are integrated, these must be retrofitted antiparallel to the switch coil.

### Information

Please refer to “Additional technical information”\* in the CustomizedSolution portal for more information on protecting the control units integrated in the vehicle electrical system from interference voltage peaks of electromagnetic superstructures and modifications.

Please contact us (see chapters 1.2.1.1 “Contact in Germany” and 1.2.1.2 “International contact”).

\*Registration required.

### 2.5.2.1 Electrical wiring / fuses

The following points shall be complied with if routing modifications are required:

- Avoid routing over sharp edges.
- Avoid routing inside excessively narrow cavities and close to moving parts.
- No additional lines are allowed to be fastened to brake hoses and brake lines.
- Additional lines must remain at a sufficient distance from brake hoses and brake lines under all operating conditions, and are not allowed to touch or chafe against such brake hoses/lines under any circumstances.
- Only lead-free PVC jacketed cables with an insulation limit temperature >105°C must be used.
- Connections must be made professionally and must be water-tight.
- The cable shall be dimensioned according to the current drawn and protected by fuses.

Max. continuous current [A]	Rated current of fuse [A]	Wire cross-section [mm <sup>2</sup> ]
0 – 4	5*	0.35
4.1 – 8	10*	0.5
8.1 – 12	15*	1
12.1 – 16	20*	1.5
16.1 – 24	30*	2.5
24.1 – 32	40**	4
32.1 – 40	50**	6
40.1 – 80	100	10
80.1 – 100	125	16
100.1 – 140	175	25
140.1 – 180	225	35
180.1 – 240	300	50

\* Shape C; DIN 72581 blade-type connector

\*\* Shape E; DIN 72581 blade-type connector



**Warning note**

No additional electrical cables or other lines are allowed to be secured to existing lines such as brake or fuel lines or cables, because standard holders might otherwise be overloaded. An independent attachment solution must be found.

**2.5.2.2 Additional circuits**

Additional circuits shall be safeguarded against the main circuit by means of suitable fuses.

All cables must be dimensioned according to the load, and protected against pulling off and the effects of impacts and heat.

When unprotected cables are routed in the area of the battery, these cables must be protected with special anti-cut hoses in accordance with series production (e.g. Aramid hose/Kevlar).

Information about sources for obtaining anti-cut hoses can be provided if required.

Please contact us (see chapter 1.2.1.1 "Contact in Germany" and chapter 1.2.1.2 "International contact").

For bodies and conversions with electromagnetic switching mechanisms (such as relays, magnetic switches, contactors and solenoid valves), these components must be equipped with integrated protective diodes (free-wheel diodes/anti-surge diodes), in order to exclude interference voltage peaks from the vehicle electrical system and the control units. If no protective diodes are integrated, these must be retrofitted antiparallel to the switch coil.

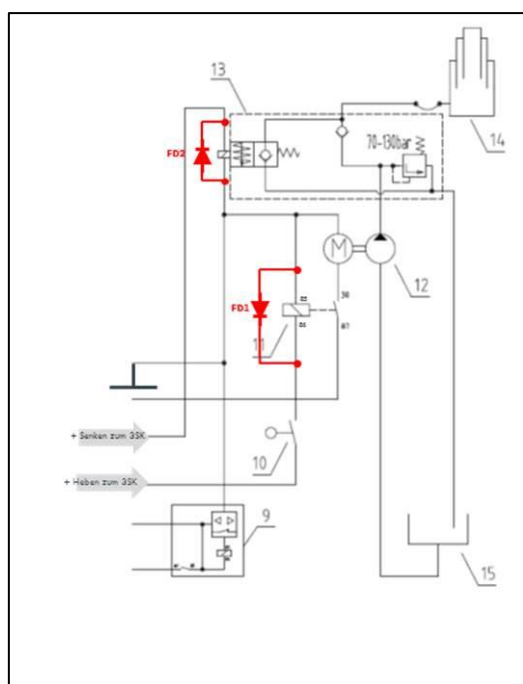

Fig. 1: Tipping control circuit

11-Electro-hydraulic tipping valve

12-Hydraulic pump with motor

13-Motor relay (lifting tipper bed)

FD1-Free-wheeling diode for motor relay

FD2-Free-wheeling diode for tipping valve

**Practical note**

For subsequent superstructures and modifications for vehicles, it is essential to make sure there are no voltage spikes >150 V in the vehicle electrical system. For conversions, suitable measures must be taken to ensure this (e.g. by using protection diodes).

**Information**

Please refer to “Additional technical information”\* in the CustomizedSolution portal for more information on protecting the control units integrated in the vehicle electrical system from interference voltage peaks of electromagnetic superstructures and modifications.

Please contact us (see chapters 1.2.1.1 “Contact in Germany” and 1.2.1.2 “International contact”).

**2.5.2.3 Retrofitting electrical devices**

Note the following for retrofitting additional electrical consumers:

- The no-load current of the basic vehicle is optimised at 20 mA. Additional electrical equipment (e.g. data loggers) which is permanently connected to the permanent positive terminal 30 reduces the time after which the vehicle engine can be reliably started by discharging the starter battery.  
Even 100 mA of additional no-load current drains 2.4 Ah per day from the battery
- If the electrical power requirement is higher, the alternators approved by Volkswagen for the vehicle must be used.
- No further loads are allowed to be connected to assigned fuses.
- No additional cables are allowed to be connected to existing cables (e.g. with insulation-piercing terminals).
- Fuse electrical equipment adequately by means of additional fuses.
- All installed electrical devices will be checked acc. to UNECE-R10 and will bear the “E” mark.

**Warning note**

Incorrect intervention or installations in the vehicle electrics/vehicle electronics can impair their function. This can lead to a failure of components or safety-relevant parts and consequently to accidents or damage to the vehicle

**Practical note**

The negative terminal of electrical consumers must always be located at the intended body earth and not at the negative battery terminal, as this can lead to falsification of the battery status detection by the on-board electronics.

**Information**

Furthermore interventions in the vehicle electrical system/vehicle electronics can result in invalidation of the warranty/operating permit.

#### 2.5.2.4 Electromagnetic compatibility

Electromagnetic compatibility (EMC) is defined as the property of an electrical system enabling it to behave neutrally with full functionality in the

vicinity of other systems. Active systems in the surrounding area are not disrupted by the system, nor is system itself impaired.

Electrical interference in motor vehicle electrical systems is caused by the individual electrical loads. At Volkswagen AG, the factory-fitted electronic components have been checked for their electromagnetic compatibility in the vehicle.

When electrical or electronic systems are retrofitted, it is also necessary to check and demonstrate their electromagnetic compatibility.

The devices shall possess a type approval in accordance with UNECE-R 10 and shall bear the “e” mark.

Volkswagen does not issue a manufacturer’s declaration for electromagnetic compatibility when additional devices are subsequently installed by body builders.

Should you have any questions, please contact Volkswagen AG. Please refer to chapter 1.2.1 “Product and vehicle information for body builders”.

#### 2.5.2.5 Mobile communication systems

##### 1. Mobile phones

Commercially available mobile phones may be operated in the vehicle interior. Observe the respective national regulations for the transmission powers during use. Information about the radio bands can be found in the current vehicle-related manufacturer's declaration.

An installation set with external aerial is recommended for an optimum transmission and reception quality and to connect to wireless networks outside of the vehicle. The appropriate interface is available for the mobile phone ex-works as special equipment.

##### 2. Mobile phones for authorities and organisations with security tasks

Two-way radios complying with the technical directives of authorities and organisations with security tasks may be installed and operated in the vehicle with the appropriate installation set (according to the vehicle-specific manufacturer’s declaration).

#### Information

Additional information about the operation of mobile two-way radios is available in the “vehicle-specific manufacturer’s declaration” for the Multivan.

It is filed in the body builder portal of Volkswagen AG under the heading: “Additional technical information”\*.

\*Registration required.

### 2.5.2.6 CAN bus

#### Warning note

Interventions in the CAN bus and connected components are unauthorised.

The CAN BUS must not be modified due to the networking and internal monitoring of electrical equipment (e.g. by interrupting, extending or “tapping”, and reading and writing). Any modification to the wiring harness in terms of length, cross-section or resistance could cause failure of safety-relevant components or result in a loss of comfort.

Internal and external vehicle diagnosis is possible via the OBD diagnostic connection (SAE 1962). Each control unit is self-diagnosis capable and has a fault memory.

Communication with the control unit can be carried out using ODIS (Offboard Diagnostic Information System) and the software that has been developed for this purpose.

#### Practical note

The body builder can use the external CAN bus interfaces on the CFCU to exchange predefined data with the data bus system of the base vehicle (CIA 447 or J1939).

Outside of these interfaces and predefined data strings, no data may be exchanged with the internal data bus of the base vehicle. Furthermore, no online interfaces may be connected to the above CAN BUS interfaces (an online interface is an interface that can potentially be connected to the Internet, such as \*Wi-Fi, Bluetooth, \*NFC, \*NAD, etc.).

In case of non-compliance, the body builder is required to have a new system test performed according to UN ECE R 155.

To prevent outside intervention in the vehicle control system, the vehicle manufacturers (OEM) are constantly implementing the UNECE regulations on cyber security (CS) and software update management system (SUMS).

If vehicles are modified or supplemented by body builders following delivery by the vehicle manufacturer, the specifications from the UNECE regulations must also be observed and implemented.

\* WLAN = wireless local area network

\*NFC= near field communication (contactless data transmission using radio frequency identification (RFID) technology),

\*NAD= network access device (telephone module)

### Information

Your Volkswagen customer service department can provide you with further information

#### 2.5.2.7 Current and signal take-off of vehicle electrical system potentials

If an electrical interface is not available or, if it is not yet available, a current take-off may take place on a limited basis, taking into account the conditions specified in section 2.5.2.2 "Additional electrical circuits".

Depending on the vehicle equipment,

the current take-off may take place at specific unoccupied fuse locations of fuse holder C.

#### Terminal 15 ignition, take-off for additional electrical equipment

At the free fuse location SC64 (see Fig. 1), the current take-off must be limited to 3 A and protected with a maximum of 5 A.

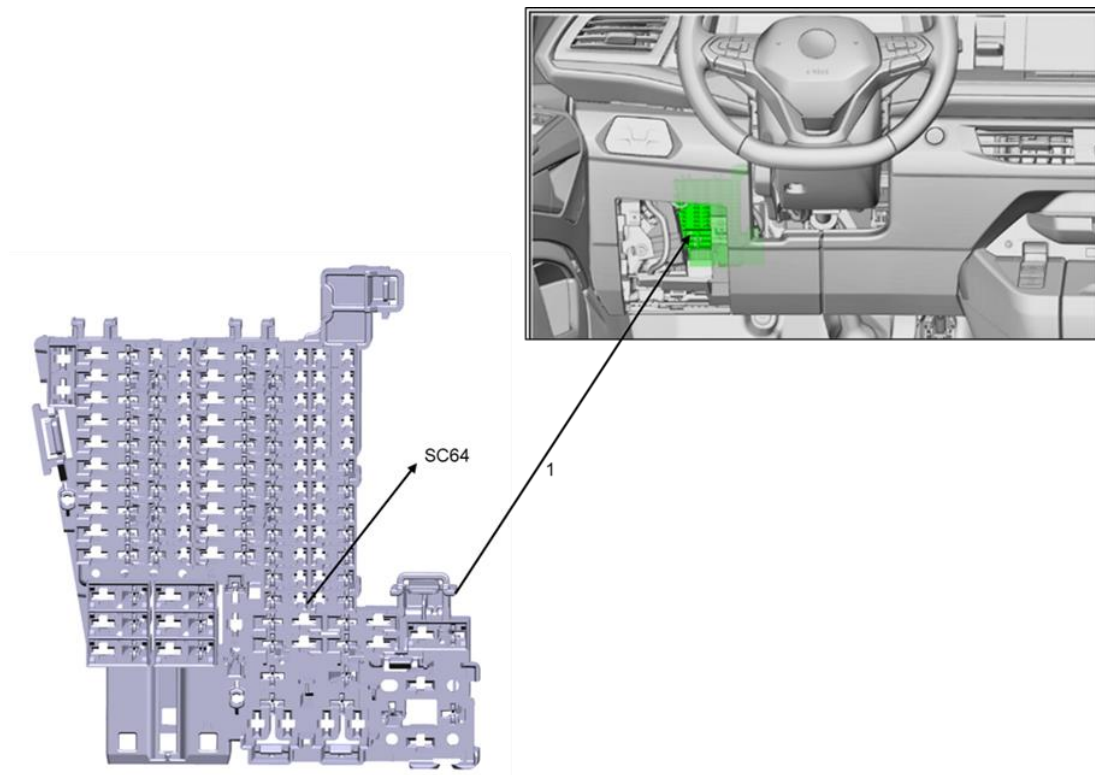

Fig. 1 Fuse holder C, left of dash panel

Fuse holder C is located in the bottom left of the dash panel.

- Next to the steering wheel on left-hand drive models
- Behind the glove compartment on right-hand drive models

The exact position and description can be found in the Owner's Manual of your vehicle.

**Terminal 30 permanent positive, take-off for small electrical equipment**

The take-off for terminal 30 can be implemented at the free fuse location SC 15 (see Fig. 2) of fuse holder C. The current draw must be limited to 3 A and protected with a maximum of 5 A.

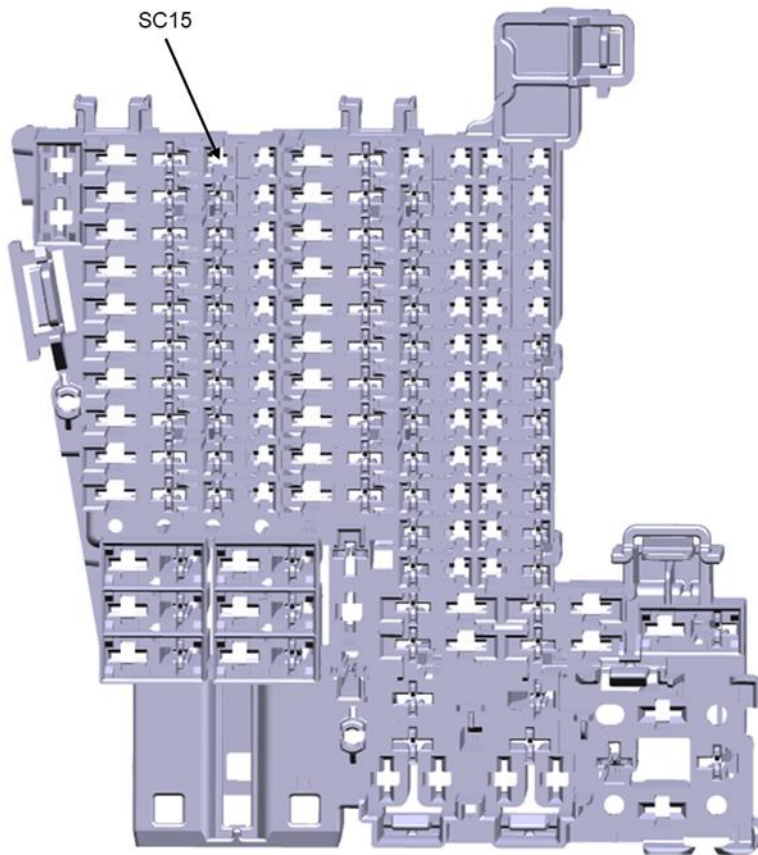

Fig. 2 Fuse holder C, left of dash panel

The position of fuse holder C can be found in Figure 1 or in the Owner's Manual of your vehicle.

### Terminal 30 permanent positive, take-off for large electrical equipment

#### Petrol and diesel engines

The take-off for terminal 30 can be implemented at the free screw connection (see figure below, position 3 ) of the central battery fuse. The current draw must be limited to 100 A and protected with an additional fuse (inline fuse) with a maximum of 125 A. The protection must be implemented in the immediate vicinity of the battery (maximum distance of 100 mm)

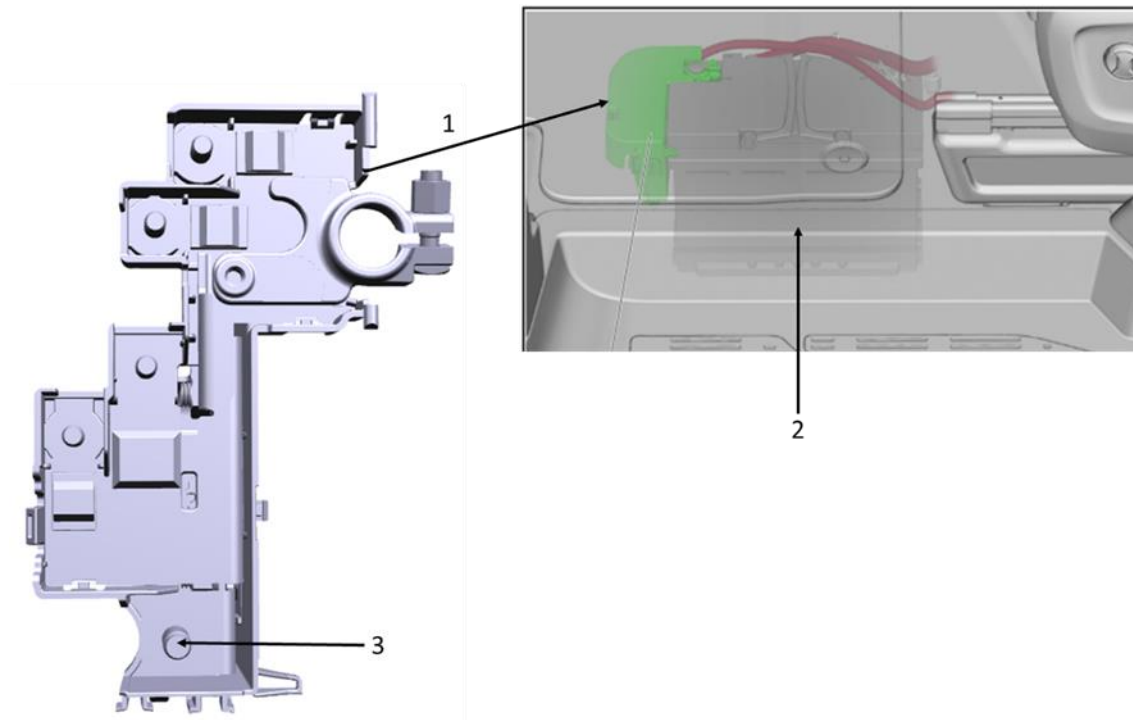

Fig. 3 Fuse holder A on the battery central fuse in the vehicle floor in front of the left-hand seat.

1= Fuse holder A

2= Battery

3= Free screw connection



### Terminal 30 permanent positive – take-off for large electrical equipment

#### PHEV (Plug-In Hybrid Electric Vehicle)

The take-off for terminal 30 can be implemented on the PHEV at the threaded bolt (see figure below, item 1) of the battery central fuse. The current draw must be limited to 100 A and protected with an additional fuse (inline fuse) with a maximum of 125 A. The protection must be implemented in the immediate vicinity of the battery (maximum distance of 100 mm).

See Fig. 3 for the position of the battery central fuse

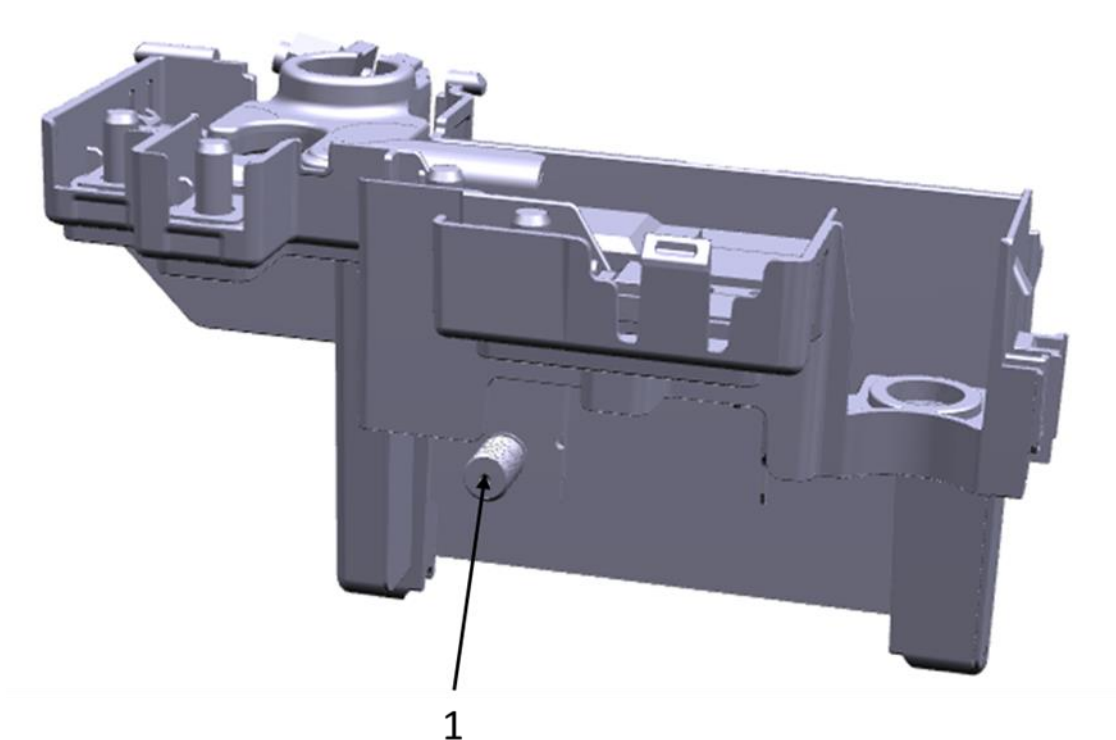

Fig. 4 Fuse holder A of the battery central fuse

#### 2.5.3 Electrical interface for special vehicles

There is one interface for external use in special vehicles and by body builders:

Customer-specific functional control unit (CFCU): control unit with access to the vehicle's CAN network.

The interface can be ordered using the following equipment numbers (PR numbers):

PR number	Description
ISO	Without an interface for external use, series production
IS2	Interface for external use, basic CFCU with body builder programming, without electrical terminal strip – without preparation for telematics
IP1	Fleet management system interface, CFCU with taxi programming

### 2.5.3.1 General notes on the interface for special vehicles

Basic requirements for using the interface:

- These interfaces are only allowed to be used by authorised specialist personnel.
- Inappropriate interventions can result in damage to the vehicle and breakdowns, and may also invalidate the operating permit.
- The parameters of the special vehicle control unit are only allowed to be set in consultation with Volkswagen.
- Connections must be made properly (see section 2.5.2.1 “Electrical wiring/fuses”).

Subject to technical modifications.

The following points must be observed at all times:

- VDE guidelines for configuration and fitting of electrical wiring and components (cable cross sections, fuses etc.)
- Only components approved by Volkswagen are allowed to be used for adapting to the vehicle electrical system.
- When using additional electrical equipment, the body builder must ensure a balanced current supply.
- EMC safety for connections after the interface is the responsibility of the company fitting out the vehicle.
- The cable cross sections of the interfaces will be maintained throughout the entire circuit, i.e. no cross-section reductions are permitted after the interface.
- Energy must only be supplied to the vehicle electrical system at potentials expressly provided for this purpose and will be fused externally in accordance with VDE guidelines.
- All electrical wiring connected to the vehicle electrical system shall be reliably and durably protected against overload to battery “+”.
- Earth potential: The specified potentials always refer to the vehicle body earth.

#### Information

Volkswagen AG workshop manuals and circuit diagrams can be downloaded from the Internet at **erWin\*** (Electronic Repair and Workshop Information from Volkswagen AG):  
<http://erwin.volkswagen.de/erwin/showHome.do>

\*Information system from Volkswagen AG, subject to payment

### 2.5.3.2 Customer-specific functional control unit (CFCU)

The functional control unit enables close integration of the base vehicle and the body.

It makes it possible to provide almost 3,000 different signals from the base vehicle that, when required, are used to activate the body functions or are also connected in logic blocks (freely configurable).

#### Basic CFCU

- Programmability and configurable inputs and outputs
- ASIL-B Ready (functional safety ISO 26262)
- Display of vehicle information as well as control of the body builder functions
- Ex-works functions (taxi programming only with CFCU PR number IP1)

Digital inputs	16
Analogue inputs	8
Outputs	24

#### Information

All inputs and outputs can be loaded up to the respective specified rated values.

Corresponding technical rated values can be found in the technical customer documentation for the CFCU.

Overloading can result in damage to the control unit, or even its destruction.

The customer-specific functional control unit (CFCU) is located behind the glove compartment on the passenger side (see Fig. 1).

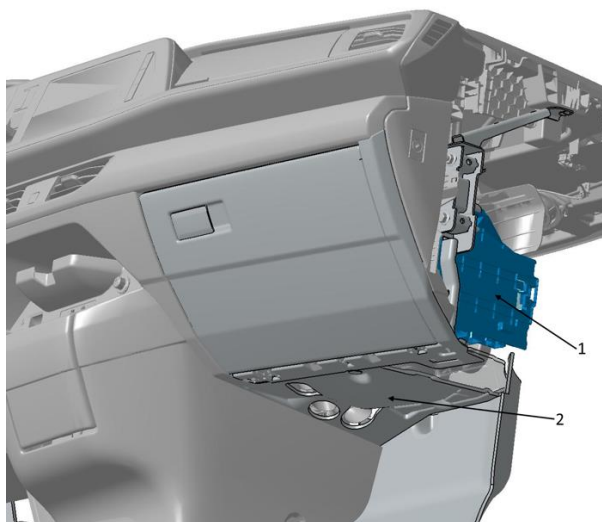

Fig. 1: Location of the CFCU, illustration for left-hand drive vehicle. On the right-hand drive vehicle, the CFCU is located on the other side accordingly.

1 = CFCU

2 = cover under the glove compartment

### 2.5.3.3 Overview of functions of customer-specific functional control unit, basic version

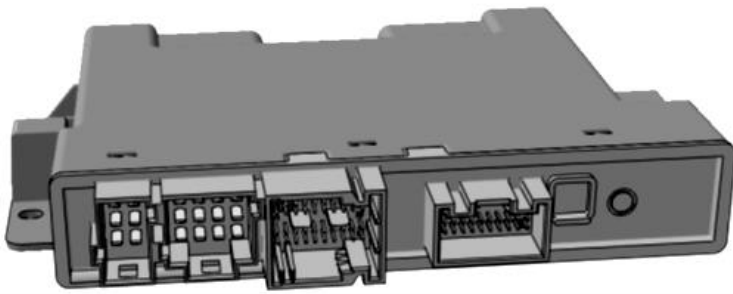

Fig.: View of customer-specific functional control unit, basic version

#### Basic CFCU

- Programmability and configurable inputs and outputs
- ASIL-B Ready (functional safety ISO 26262)
- Display of vehicle information as well as control of the body builder functions
- Ex-works functions (taxi programming only with CFCU PR number IP1)

#### Interfaces

- CIA447
- J1939

#### **Information**

Technical documentation on the CFCU and further information on the requesting and processing procedure can be found in the CustomizedSolution portal under the link:

[CFCU Functional Control Unit | CustomizedSolution Portal \(customized-solution.com\)](https://www.customized-solution.com).

You must register on the CustomizedSolution portal in order to access this.

The configuration of the customer-specific functional control unit (CFCU) can be ordered via the CS portal.

### Practical note

The body builder can use what is known as the body builder CAN\* (also called J1939 or FMS\*\* CAN) and the CANopen CAN (also called CIA447) of the CFCU as an open CAN bus to communicate with the base vehicle for read access and in some cases write access as well. When the second-generation CFCU is used, it is then also possible to use both CAN interfaces in parallel.

To prevent outside intervention in the vehicle control system, the vehicle manufacturers (OEM) gradually implemented the UNECE regulations on cyber security (CS) and software update management system (SUMS). If vehicles are modified or supplemented by body builders following delivery by the vehicle manufacturer, the specifications from the UNECE regulations must also be observed and implemented.

In the future, it must therefore be technically ensured that no unauthorised messages are written to the respective vehicle CAN via external interfaces or online. External messages on the CAN can affect the base vehicle's vehicle control system.

The body builder must ensure that no online control units may be connected to the CFCU, in order to minimise this risk.

### 2.5.4 Vehicle battery

The main battery is installed in the floor area on the left in front of the driver seat.

PR no.	Designation	Battery capacity	Dimensions (Length × height × width) [mm]	Max. weight [kg]
J2D	AGM* absorbent glass mat battery	68 Ah / 380 A	278 x 190 x 175	21

\*AGM : absorbent glass mat battery

If a vehicle is not used for a long time, its battery gradually discharges due to the electrical loads (e.g. clock, tachograph, 12 volt socket) and can suffer permanent damage.

To prevent this damage from occurring, check the battery open-circuit voltage in accordance with the maintenance cycle and charge the battery (see chapter 1.2.6 “Recommendations for vehicle storage”).

#### Practical note

Avoid totally discharging the battery. Totally discharging the battery may cause permanent damage to the battery.

The battery voltage must be higher than 12.25 V.

The battery voltage under load must never fall below 11.9 V. If necessary, an idle phase (electrical equipment off) must be implemented until the open-circuit voltage increases to 12.25 V.

### 2.5.5 Retrofitting of alternators

If additional electrical equipment is retrofitted, the increased power requirement can be met by using more powerful alternators.

The following equipment is available ex works for this purpose:

Order number (PR number)	Designation
NY0	Battery / alternator standard capacity
8GU *	Alternator 140 A
8GV	Alternator 180 A
9G0 *	Alternator 230 A
9G1 **	Alternator 220 A
9G6 **	Alternator 160–250 A

\* Expected release in the second quarter of 2024 with release of UNECE 155/156 Cyber Security

\*\* Expected to be discontinued in the second quarter of 2024 with the release of UNECE 155/156 Cyber Security

Please use the PR number ordered to find out which alternator has been installed in your vehicle ex works. The alternator version installed is determined by the equipment ordered in the base vehicle. In hybrid vehicles, the PR No. 8GJ DC/DC converter is fitted; **no** alternator can be modified.

If other alternators are to be retrofitted, the following points should be observed:

- Vehicle parts and their function should not be impaired by the installation of a generator.
- The capacity of the battery and power supplied by the alternator must be dimensioned sufficiently.
- The alternator circuit requires additional fusing (see “Electrical wiring / fuses”).
- The cable cross-section should be dimensioned according to the current drawn (see chapter 2.5.2.1 “Electrical wiring/fuses”).
- The higher power requirement can make it necessary to replace the starter/alternator warning harness. We recommend Volkswagen genuine parts for this.
- Ensure that electrical wiring is routed correctly (see chapter 2.5.2.1 “Electrical wiring/fuses”).
- The accessibility of the ancillaries installed and simple maintenance possibilities may not be impaired.
- The necessary air supply and the engine cooling may not be impaired.
- The guidelines of the equipment manufacturer for the compatibility with the base vehicle should be observed.
- The Owner's Manual and the maintenance manual for the ancillaries should be handed over when the vehicle is delivered.

### 2.5.6 Driver assist systems

#### Warning note

Improper interventions in, or installations in, vehicle systems, safety-relevant components or driver assist systems can impair their function. This can result in failure or malfunctions of components or safety-relevant components. Accidents or damage to the vehicle may occur as a result.

#### Practical note

In vehicles with assist systems (such as the Lane Assist), conversions may cause falsification of the calibration. Flawless function of the multifunction camera and the ACC\* would not be ensured. Once a body has been built or conversion made, a calibration of the driver assist systems installed must therefore be carried out by an authorised specialist workshop.

#### Information

More information on installation and removal of the assist systems, such as ACC\* and multi-function camera can be found in the repair guideline (wheels, tyres, vehicle measurement repair group 44 and electrical system, repair group 96) on the Internet at: **erWin\*\*** (Electronic Repair and Workshop Information from Volkswagen AG): <http://erwin.volkswagen.de/erwin/showHome.do>

\*AdaptiveCruiseControl

\*\*Information system from Volkswagen AG, subject to payment



### 2.5.7 Earth points

Use the earth points provided by Volkswagen for subsequent electrical add-ons or installations to ensure an optimum earth connection to the base vehicle.

#### Warning note

The use of other earth points can lead to malfunctions in safety systems. This can lead to a failure of components or safety-relevant parts and to error messages in the instrument cluster.

A maximum of 4 terminals are allowed to be screwed to an earth point.  
The earth points of the safety systems are not allowed to be used for bodies.

#### Information

You will find a general overview and more information on earth points in the current circuit diagram sheet no. 801/1.

Volkswagen AG workshop manuals and workshop information can be downloaded from the Internet at **erWin\*** (Electronic Repair and Workshop Information from Volkswagen AG):

<http://erwin.volkswagen.de/erwin/showHome.do>

\*Information system from Volkswagen AG, subject to payment

Please contact us if you have any further requirements (see chapters 1.2.1.1 "Contact in Germany" and 1.2.1.2 "International contact").

## 2.6 Engine peripherals / drive train

In the event of modifications to noise-relevant components such as the engine, exhaust system, tyres, air intake system etc., noise measurements shall be carried out acc. to EC Directives. The permitted values are not allowed to be exceeded.

The national regulations and directives apply.

Components for sound insulation that are installed as standard must not be modified or removed (see also chapter 2.4.4 "Acoustic insulation").

### 2.6.1 Engine / drive train components

- No modifications to the engine air intake system are permitted.
- Subsequent solutions regarding engine speed control are not possible.
- Modifications to the cooling system (radiator, radiator grille, air ducts etc.) are not permitted.
- Keep cooling air intake areas clear.

### 2.6.2 Drive shafts

The correct configuration and implementation of a modified powertrain prevents noise and vibration, and should only be performed by a company which is qualified to build drive shafts.

Only genuine Volkswagen parts should be used.

### 2.6.3 Fuel system

No modifications are permitted to the fuel system, and any such modifications may result in invalidation of the vehicle's operating permit.

If the fuel system has to be modified for the conversion, the body builder is solely responsible for the work being carried out correctly, including all the components and materials used.

A new operating permit must be applied for from the registration authority.

Comply with the following points if making any modifications to the fuel system:

- The whole system must be permanently leak-proof in all operating conditions.
- Ensure good quality refuelling if modifications are made to the tank filler pipe, and avoid any siphon effect in the pipe routing.
- All components that come into contact with fuel must be suitable for the particular type of fuel used (e.g. petrol/diesel/ethanol additive etc.) and the ambient conditions in the installation location.
- Hoses must retain their shape and remain adequately stable throughout the service life, in order to ensure that there is no constriction in the cross section (e.g. hoses acc. to DIN 73379-1)
- Multi-ply hoses should be preferred.
- Install reinforcing support sleeves at the connections between hose sections so as to prevent any constriction at the clip connection and to guarantee leak-tightness.
- At the connections, use spring-type clips which automatically compensate for possible settling behaviour of the material and to maintain the preload. Hose clips with worm threads must be avoided.
- All parts of the fuel filler system must be routed at a sufficient distance from moving parts, sharp edges and components at high temperature, in order to avoid damage.
- In vehicles with petrol engines (also applies to plug-in hybrid vehicles), the activated charcoal filter is located directly on the fuel tank. The position of the activated charcoal container and its purge line to the engine must not be changed. The same applies to the position of the fresh air intake in the wheel housing.
- In the case of plug-in hybrid vehicles, a shut-off valve (FTIV: fuel tank isolation valve) and a pressure sensor are also integrated on the fuel tank. The entire ventilation concept for the fuel tank must be left unmodified.
- Do not attach heat-conducting components or components that restrict the installation space.
- Modifications to the fuel pump, fuel line length and fuel line routing are not permitted. Modifications to these mutually matched components can impair the function of the engine.

- Modifications to the body in the area of the fuel tank require the fuel tank to be removed first.
- If the body builder replaces the standard tank with a different fuel tank, it must be ensured that the ground clearance with the new tank is not less than that with the standard tank. Exceptions are possible for vehicles for special applications (e.g. vehicles for transporting people with disabilities). Please contact us (see chapter 1.2.1.1 “Contact in Germany” and 1.2.1.2 “International contact”).

Comply with the workshop manuals of Volkswagen AG.

#### Information

Volkswagen AG workshop manuals and workshop information can be downloaded from the Internet at **erWin\*** (Electronic Repair and Workshop Information from Volkswagen AG):  
<http://erwin.volkswagen.de/erwin/showHome.do>

\*Information system from Volkswagen AG, subject to payment

### 2.6.4 Exhaust system

Modifications to the exhaust system up to the centre silencer and in the area of the components for exhaust treatment (catalytic converter, lambda probe etc.) are never permitted.

If a modification is required to the exhaust system for the add-on/removal/conversion nevertheless, this can have effects which are relevant to registration. Please contact us in advance regarding the scope of your conversion so that we can advise you.

We recommend that you use VW genuine parts and comply with the workshop manuals of Volkswagen AG.

#### Information

You will find further information on installation and removal of the exhaust system on the Internet at **erWin\*** (Electronic Repair and Workshop Information from Volkswagen AG):  
<http://erwin.volkswagen.de/erwin/showHome.do>

\*Information system from Volkswagen AG, subject to payment

#### Information

Country-related regulations and guidelines shall be complied with

Exceptions require the approval of Volkswagen AG before the conversion, and shall be documented in a registration report detailing the modifications and adjustments made.

Please contact us before starting your conversion (see chapters 1.2.1.1 “Contact in Germany” and 1.2.1.2 “International contact”).

#### Warning note

Attention! Danger of fire!

The lengths and routings of the exhaust system have been configured optimally with regard to their temperature properties. Modifications may result in relatively high to extreme heating of the exhaust system and the surrounding components (drive shafts, fuel tank, floor panel etc.).

2.6.4.1 Exhaust system (MAR\*)

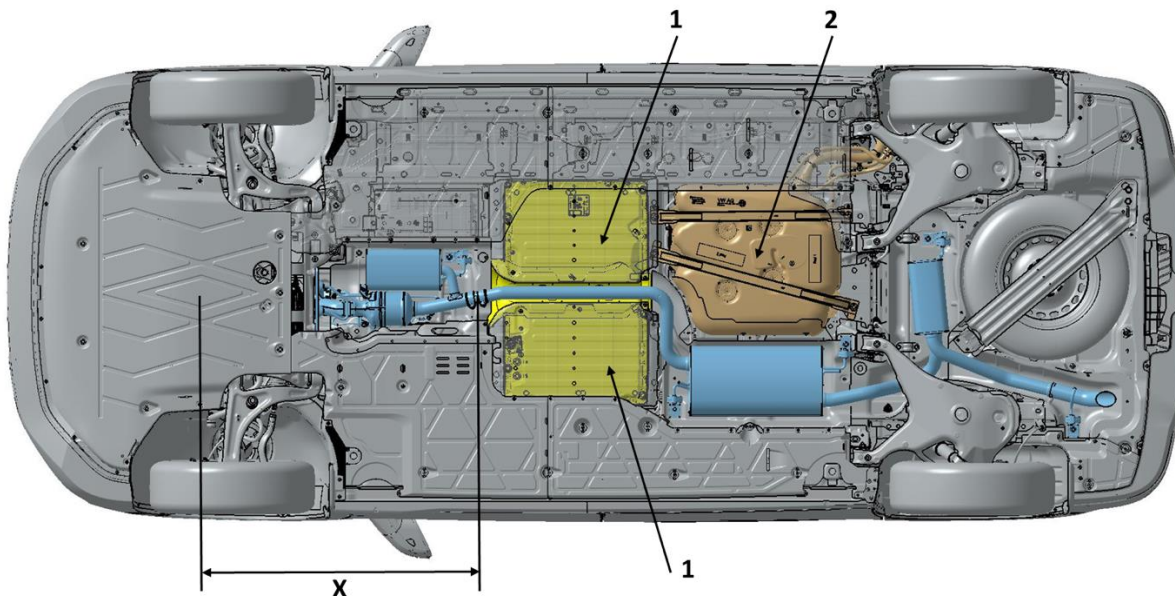

Fig. 1: Exhaust system, short MAR\* overhang with PHEV\*\* (plug-in hybrid electric vehicle) (illustration: drive type 4x2, 160 kW)

1: High-voltage battery

2: Fuel tank

X: Area in which modifications are not permitted.

\*MAR: emission control module

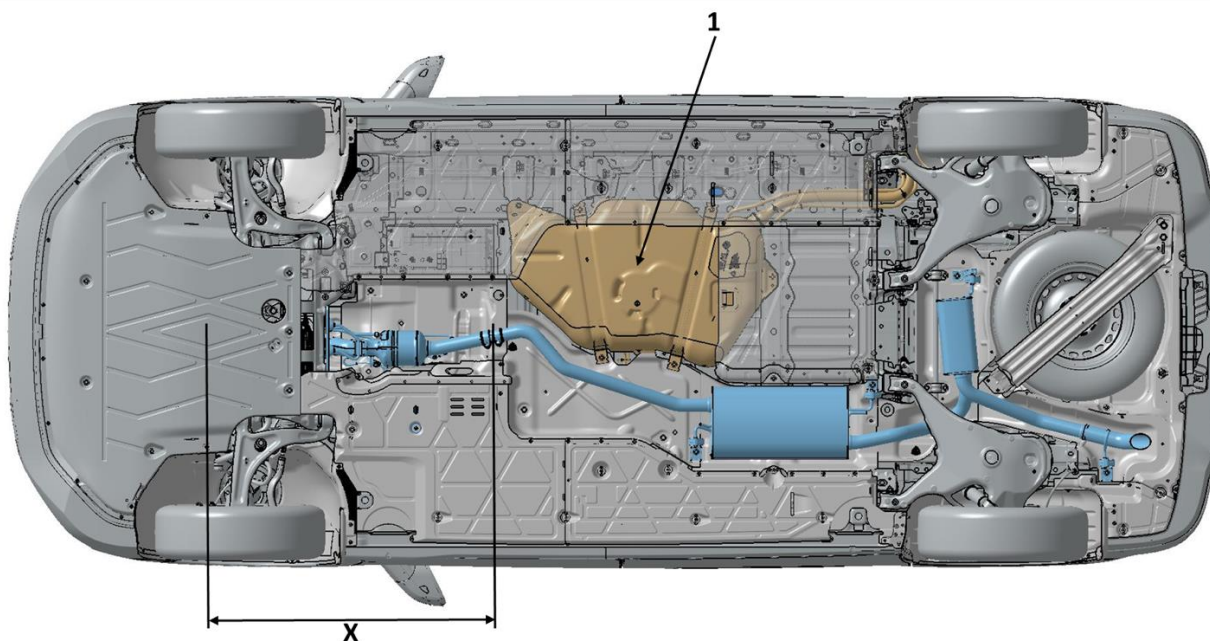

Fig. 2: Exhaust system, short MAR\* overhang (illustration: drive type 4x2, 100 kW TSI)

1: Fuel tank

X: Area in which modifications are not permitted.

\*MAR: emission control module

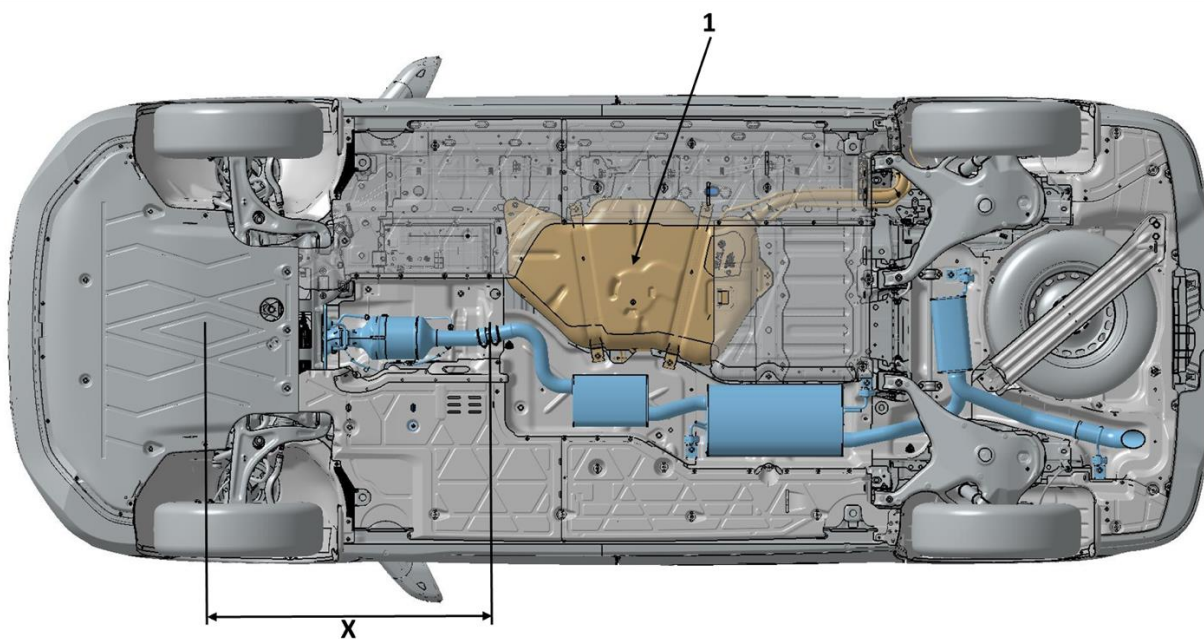

Fig. 3: Exhaust system, short MAR\* overhang (illustration: drive type 4x2, 150 kW TFSI)

1: Fuel tank

X: Area in which modifications are not permitted.

\*MAR: emission control module

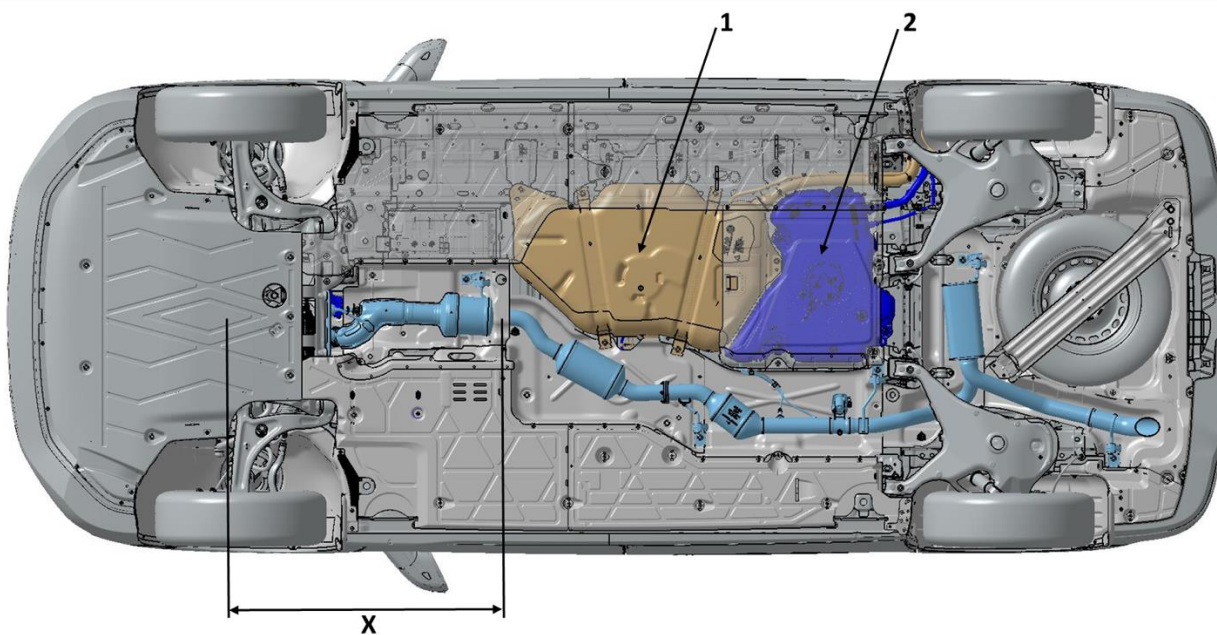

Fig. 4: Exhaust system, short MAR\* overhang (illustration: drive type 4x2, 110 kW TDI)

1: Fuel tank

2: AdBlue tank

X: Area in which modifications are not permitted.

\*MAR: emission control module

Modifications to exhaust systems with an SCR system are not permitted under any circumstances. Neither the geometry nor the position of the sensors are allowed to be changed.

If a modification to the exhaust system due to body design, removal or conversion is nevertheless required, this can have consequences relevant to approval. Please contact the body builder's support team in advance regarding the extent of your conversion so that we can advise you.

Changes as a result of add-ons or conversions are only possible outside of the SCR emission control system area indicated by X (see Figs. 1 to 4).

#### Practical note

When working on lines carrying AdBlue®, comply with the workshop manuals from Volkswagen AG. Otherwise, AdBlue® could crystallise and lead to damage to system components.

### 2.6.5 SCR system (Euro 6)

An ex-works SCR system is available to meet Euro 6 emissions regulations for diesel engines.

The SCR catalytic converter selectively converts the nitrogen oxide (NO<sub>x</sub>) exhaust gas component into nitrogen and water. This conversion is undertaken using AdBlue®, a synthetically manufactured, aqueous reducing agent. AdBlue® comprises 32.5 per cent high-purity urea and demineralised water. The AdBlue® solution is not mixed with the fuel, but carried in a separate tank.

From here, the AdBlue® is injected continuously into the exhaust gas line in front of the SCR catalytic converter. The AdBlue® reacts with the nitrogen oxides in the SCR catalytic converter and is split into nitrogen and water. The dosing is determined by the exhaust mass flow. The engine management system is informed by an NO<sub>x</sub> sender after the SCR catalytic converter and ensures exact dosing. The AdBlue® reducing agent is non-poisonous, odourless and water-soluble.

### 2.6.5.1 Installation position of the AdBlue® tank in the vehicle

The AdBlue tank is found at the rear of the underbody, on the left (in the direction of travel).

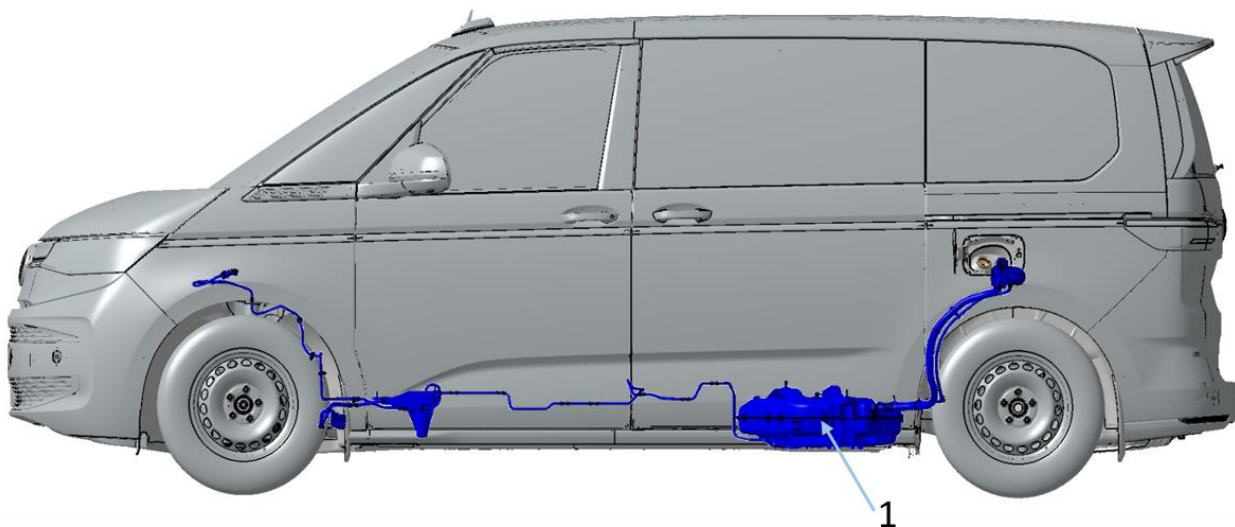

Fig.1 Installation position of the AdBlue tank on the vehicle / 1 AdBlue tank

The SCR system, which consists of an AdBlue tank, line and metering valve, forms an optimised electrical-hydraulic unit. The location of the reducing agent tank, the heated metering line and their relative position to the vehicle shall not be changed (see chapter 2.6.4 “Exhaust system”).

### 2.6.5.2 Filling opening of the AdBlue® tank

The filling opening of the AdBlue tank is located behind the tank flap next to the fuel filling opening.

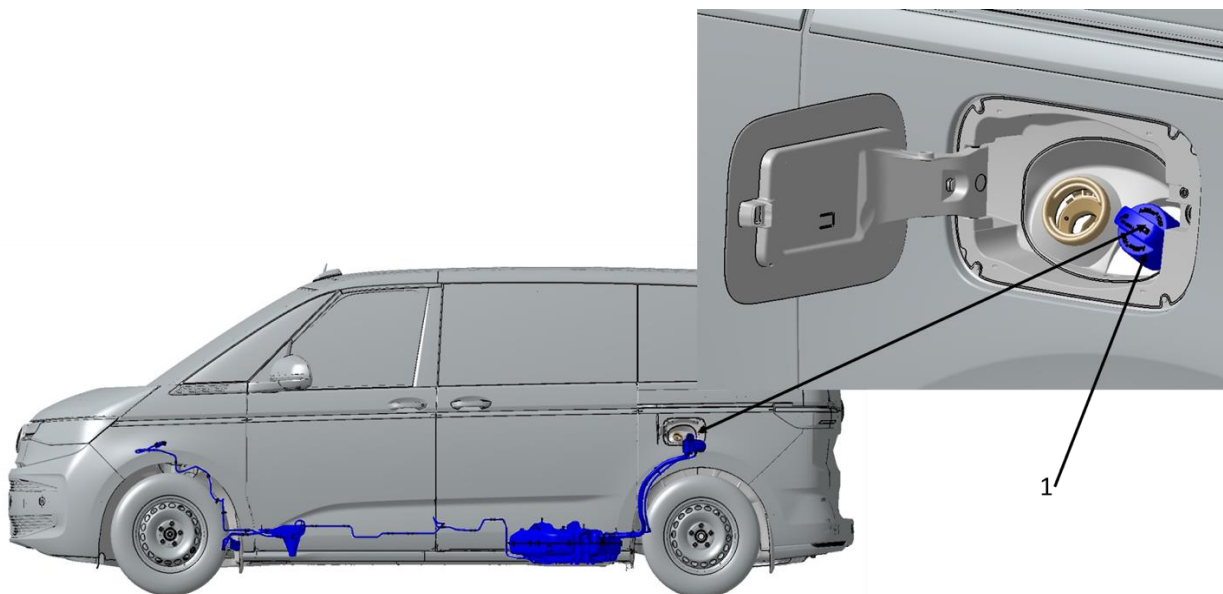

Fig.1 Filling opening of the AdBlue® tank in the engine compartment (schematic diagram) / single filler neck of the AdBlue tank



**Practical note**

AdBlue® attacks surfaces such as painted surfaces, aluminium, plastics, clothing and carpets. If AdBlue® is spilled, wipe it up as quickly as possible with a damp cloth and plenty of cold water. Remove crystallised AdBlue® with warm water and a sponge.

More information about AdBlue® is available in ISO standards ISO 22241-1 to 5.

**Practical note**

To ensure the purity of AdBlue®, never reuse AdBlue® that has been extracted from the reducing agent tank.

Comply with the country-specific laws and regulations regarding correct storage and disposal.

**Information**

More information and safety instructions for the SCR system can be found in the Owner's Manual for your vehicle and the Workshop Manuals of Volkswagen AG online:  
<http://erwin.volkswagen.de/erwin/showHome.do>

## 2.7 Add-ons/units

### 2.7.1 Roof carriers

Roof loads raise the centre of gravity of the vehicle and lead to a high dynamic axle load shift. Also, there is greater body lean when driving on rough roads and when cornering. The vehicle handling is significantly impaired.

For this reason, roof loads should be avoided if at all possible.

At least two base carriers are required to secure the roof load! In the case of very long objects, another base carrier must be used at the rear mounting point. The maximum permissible roof load of 100 kg must not be increased if another base carrier is added.

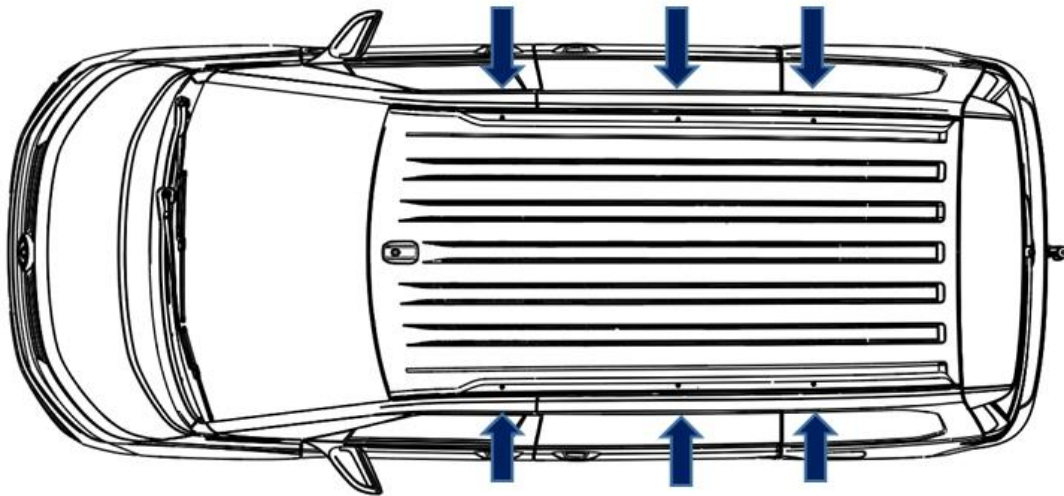

Fig. 1: Standard roof mounting points

## 2.7.2 Towing brackets

### 2.7.2.1 Maximum trailer weights

Only trailer towing brackets approved by the factory are permitted to be used as hitches.

Trailer towing brackets (ball hitches) can be ordered as optional equipment ex-works using the following PR numbers:

- 1D7 \*: Preparation for towing bracket
- 1M9: Folding towing bracket with electrical unlocking (including trailer stabilisation)  
Maximum trailer weight 750 kg unbraked and 1,600 to 2,000 kg braked (depending on engine) with 12% hill climbing ability.
- The gross vehicle weight rating may not be exceeded.

\* Only in markets without UNECE requirements

The maximum permitted draw bar weight is 80 kg.

The max. permitted gross combination weight specified in the papers must not be exceeded. The actual weight of the trailer load is not allowed to exceed the permitted gross weight of the towing vehicle.

### 2.7.2.2 Retrofitting a trailer towing bracket

Comply with the following points when retrofitting a trailer towing bracket:

- When fitting a trailer towing coupling in the EU, the specified installation dimensions and clearances in the current version of UNECE-R 55 must be observed. Any other applicable national regulations must be taken into account.
- The necessary clearance of the trailer behind the towing vehicle must be guaranteed (UNECE-R 55).
- The vehicle shall be presented to a motor vehicle test centre with responsibility for this matter.
- No factory-fitted extension to the trailer towing coupling is available.
- There are attachment points in the vehicle longitudinal members.
- The gross vehicle weight rating depends on the engine and must be determined before retrofitting.
- Unspecified details shall be selected in a reasonable manner.
- The test of dimensions and angles shall be undertaken with suitable length and/or angle measuring instruments.

## 2.8 Raising the vehicle

1. With lifting platforms

The vehicle is only allowed to be raised at the lifting points provided. Refer to the corresponding repair manual for information about the lifting points.

2. With a jack

See the owner's manual for the procedure and jacking points on all vehicle variants.

## 3 Modifications to closed bodies

### 3.1 Interior

The following points shall be observed without fail for conversions:

The driver and front passenger airbag units, the airbags and the belt tensioners are pyrotechnical objects.

Their handling, transport and storage are subject to legislation on potentially explosive substances, and the responsible public authority or government agency must therefore be notified. Purchase, transport, storage, installation and removal as well as disposal are only allowed to be performed by trained personnel in accordance with the corresponding safety regulations.

Modifications in the cockpit area and above the shoulder line shall be conducted in accordance with the criteria of the head impact tests acc. to UNECE-R 21. This applies in particular to the deployment zones of airbags (wooden trim, additional installations, mobile telephone retainers, bottle holders etc.).

Painting or surface treatment of the dash panel, steering wheel impact absorber and the tear seams of the airbags is not permitted.

The permitted centre of gravity position and axle loads are not allowed to be exceeded.

The interior fitting-out shall be configured with soft edges and surfaces.

Installations shall be manufactured from flame-retardant materials, and be firmly installed.

Unhindered access to the seats shall be guaranteed.

No projecting parts, corners or edges that could cause injuries are allowed to be located in the area of the seats.

#### 3.1.1 Safety features

##### Warning note

In case of interventions by the body builder in the structure of the vehicle, such as

- modifications to the seats and consequently altered kinematics of the occupants in case of a crash
- modifications to the front body
- installations of parts in the vicinity of the exit openings and the deployment range of the airbags (see owner's manual of the vehicle)
- installation of third-party seats
- modifications to the doors

the safe function of the front airbag, side airbag and belt tensioners is no longer guaranteed. This could result in personal injuries.

Vehicle components that cause vibration must not be installed near the airbag control unit or the sensors.

Modifications to the floor structure in the area of the airbag control unit or the satellite sensors are also unauthorised.

The Multivan is equipped with head and thorax airbags in the 1st row of seats in all equipment lines.

In the 2nd and 3rd rows of seats, curtain airbags and seat belts are installed in the standard equipment for all vehicles.

**Important note:**

Please note that deactivation of the side airbag causes the airbag warning light in dash panel to light up continuously. For information about the deployment zones of the airbags, refer to the owner's manual of the vehicle.

**3.1.2 Retrofitting seats****3.1.2.1 Installation of standard seats**

- The strength data for seats available ex-works is only valid in conjunction with the series attachment system.
- When installing seat belts and belt locks, only Volkswagen genuine parts must be used.

**Retrofitting of standard seats in the passenger compartment**

When retrofitting standard seats, make sure that the added seats are entered in the registration documents. Only the number of seats that have been ordered are documented in the registration documents after production of the vehicle. A belt system for the maximum number of standard seats is fitted in the vehicle for all equipment lines.

**Seat position detection:**

The seat position detection for retrofitted series seats must be coded in the instrument cluster.

**Warning note**

When the seat belts and seats are re-fitted, the prescribed bolts must be used and tightened to the original torque. You will find detailed information on torques in the workshop manuals.

Only fit seat covers or protective covers that are expressly approved for use in the vehicle.

Otherwise, the side airbag in the 1st row of seats cannot unfold optimally if triggered and therefore cannot protect the occupants optimally.

**Information**

Volkswagen AG workshop manuals and workshop information can be downloaded from the Internet at **erWin\*** (Electronic Repair and Workshop Information from Volkswagen AG):

<http://erwin.volkswagen.de/erwin/showHome.do>

Or contact your Volkswagen Commercial Vehicles partner.

\*Information system from Volkswagen AG, subject to payment

### 3.1.2.2 Installation of aftermarket product seats or use of standard seats deviating from the standard seating

As an alternative to retrofitting standard seats in accordance with chapter 3.1.2.1, seats can also be installed subject to the following conditions:

- A seat deviating from the standard seating must be equipped with 3-point belts. Seat units without seat belts, or with two-point belts are not permitted.
- Seats and safety belts and their fastenings must be tested or approved in accordance with the laws, directives and approval regulations that apply in the countries of registration.
- It is essential not to exceed the height of the centre of gravity (H-point) when retrofitting seats. (see definition of H-point as per VW 80310). Refer to the build dimension drawings for more information and current documents about the position of the H-point.
- If seat belts and belt locks other than those available from the factory are installed, ensure that all registration-related regulations are observed. (Please also refer to chapter 2.4.2.1 “Belt anchor points”.)

#### Warning note

Seats must not be attached to the wheel housing. This also applies to wheel housings that are lowered. Otherwise damage could be caused to the vehicle (e.g. wheel housing and tyres) and accidents could result.

If seats other than those available from the factory are installed with factory seat belts, only belt locks that fit with the buckles on the factory seat belts may be used.

Otherwise the seat belt cannot be locked in the belt lock as intended and persons could be injured in the event of an accident.

#### Practical note

Modifications to the original series production condition can result in the withdrawal of type approval.

Country-specific laws, directives and approval regulations shall be observed!

## 4 Implementations of special bodies

### 4.1 Vehicles for transporting persons with restricted mobility

A wide range of driving aids for disabled persons, catering to persons with various disabilities, is available as optional equipment from Volkswagen AG. For more information, please contact your Volkswagen dealership.

#### Information

For more information, refer to the Volkswagen AG website at:

<https://www.volkswagen-nutzfahrzeuge.de/de/modelle/branchenloesungen-und-umbauten/menschen-mit-behinderung.html>

#### 4.1.1 Base vehicle equipment

When planning the special vehicle, select the equipment of the base vehicle according to the requirements of the future application (see also chapter 1.3.1 “Selecting the base vehicle”).

Please note that certain conversions are only allowed to be used by people with corresponding entries in their driving licence.

#### Practical note

For ease of implementation, we recommend also ordering the customer-specific function control unit (CFCU\*) with body builder programming.

Further information can be found in chapter 2.5.3 “Electrical interface for special vehicles”.

\*CFCU: customer-specific functional control unit, see also chapter 2.5.3.3.

#### 4.1.2 Selection of steering rack for conversions for people with disabilities

In addition to the standard power steering (PR no. 1N3), Volkswagen offers the T7 with power steering with mobility aid (PR no. 1N5) as special equipment.

The power steering is given a lower steering torque by setting a different mobility characteristic. This has an effect particularly at relatively slow vehicle speeds (parking, urban driving).



#### 4.1.3 Notes on conversion solutions for the wheelchair transporter

- If the routing of the exhaust system is modified or if sections of the pipe are cut out, it is necessary to ensure that there are adequate clearances to other components even when the exhaust system expands at operating temperature, and that touching is avoided.
- The general certificate of roadworthiness of the whole vehicle will be invalidated if the exhaust system is modified. The wheelchair transporter is classified as a “special purpose” vehicle, which means the approval for the whole vehicle is retained. If a modified rear silencer is used, it is only necessary to provide verification of the noise level during “driving past at accelerated speed” for the vehicle.
- If modifications are made to the exhaust system and the fuel system, it is necessary to ensure adequate protection against fire by fitting heat shields.
- If the vehicle rear is converted to create a flat ramp for easy wheelchair access, it should be ensured that this area has adequate ground clearance so that a sufficiently large ramp angle can be achieved (e.g. ferry, multi-storey car park with the permitted rear axle load).
- Any PDC sensors must remain in their original position and function as in the production vehicle.

#### 4.1.4 Notes on installing manual operating devices for the foot brake:

- Do not modify the brake pedal when installing manual operating devices. Select a clamped solution for connecting the manual operating device.
- The operating travel of the manual operating device must also be sufficient for a blocking braking, with reserve travel for a circuit failure.
- If a manual operating device is used for the accelerator and brake, the standard pedals must be covered by suitable means.

#### 4.1.5 Deactivating airbags / belt tensioner systems

The customer service workshop can also deactivate/reprogram the driver airbag/belt tensioner in exceptional cases, e.g. for drivers with a disability (with entry in the driving licence), if there is insufficient distance to the steering wheel or if a smaller steering wheel for wheelchair users is fitted (self-drive) and no airbag can be installed. For more information, please contact Volkswagen customer service.

The following points should be observed when deactivating airbag/belt tensioner systems:

1. The registration document for airbag/belt tensioner systems issued by Volkswagen Dealership must be stored in the vehicle wallet and handed over to the next owner on sale of the vehicle.
2. A warning sticker indicating this deactivation must be attached to the dash panel in clear view and must not be removed before the airbag is reactivated.
3. Alterations to/deactivations of functions (airbag, belt tensioner, seat-occupied sensor etc.) must be entered immediately in the vehicle documents (TÜV, DEKRA, responsible technical service).
4. Other users/purchasers of the vehicle must be informed that the specified safety systems have been deactivated and of the increased safety risk this entails.
5. We strongly recommend that deactivated airbags/belt tensioner systems are reactivated by a Volkswagen dealership before the vehicle is sold. This applies in particular if the vehicle is sold or permanently transferred to persons who do not fulfil the requirements for airbag deactivation.

**Warning note**

Deactivation means that the additional safety function of the airbag/belt tensioner is no longer ensured. Accidents may result in more severe injuries than those in which the airbag/belt tensioner is activated. Vehicle occupants have a greater risk of injury.

**Practical note**

Please note that permanently deactivating or removing the driver airbag also invalidates the belt unit type approval (belt tensioner, belt retractor). If an airbag is deactivated, the corresponding belt unit (for systems without airbags) must always also be adapted.

Follow the procedure for deactivating airbags specified in the workshop manual (see General body repairs, interior, repair group 1.8 Airbag deactivation and repair group 69 Passenger protection).

You can find the Workshop Manual online at **erWin\*** (Electronic Repair and Workshop Information from Volkswagen AG):

<https://erwin.volkswagen.de/erwin/showHome.do>

\*Information system from Volkswagen AG, subject to payment

Special information for deactivating side airbags (replacing driver seat with disability seat):

1. In Germany, the second regulation (2.SprengV) of the Explosives Act (SprengG) applies to the storage and preservation of seats with side airbags. Customers who wish to store removed seats at their homes must first clarify the requirements for private storage with the responsible trade supervisory board.
2. To store a removed seat, a safety plug must be fitted on the detached cables.

Please also comply with the following chapters during your conversion:

- 1.3.1 Selecting the base vehicle
- 2.2.1 Permitted weights and unladen weights
- 2.3.2 Modifications to the body-in-white
- 2.5.2.1 Electrical wiring and fuses
- 2.5.2.3 Retrofitting electrical devices
- 2.5.3 Electrical interface for special vehicles
- 2.5.4 Vehicle battery
- 2.5.5 Retrofitting of alternators
- 2.6.3 Fuel system
- 2.6.4 Exhaust system
- 3.1.1 Safety features

## 4.2 Taxi / private hire car

### 4.2.1 Preparation ex works for taxis and private hire cars

The following setups are available ex works with PR numbers:

- Taxi setup without provision for radio (PR number F4E).
- Private hire car setup without provision for radio (PR number F5P).

The IP1 interface is the content of the F4E and F5P equipment.

Additional taxi equipment, such as roof sign provisions and taxi alarm, are available for the German market.

## 4.3 Plug-in hybrid electric vehicle (PHEV)

### 4.3.1 High-voltage system

The high-voltage system consists of the following components:

- High-voltage battery
- Power electronics
- Electric motor
- High-voltage air conditioner compressor
- High-voltage battery charging unit
- High-voltage battery charging socket
- Orange-coloured high-voltage wires and connectors
- High-voltage heater

All work carried out on the high-voltage system must be performed exclusively by a suitably qualified specialist company deploying suitably qualified and trained staff in accordance with Volkswagen's policies.

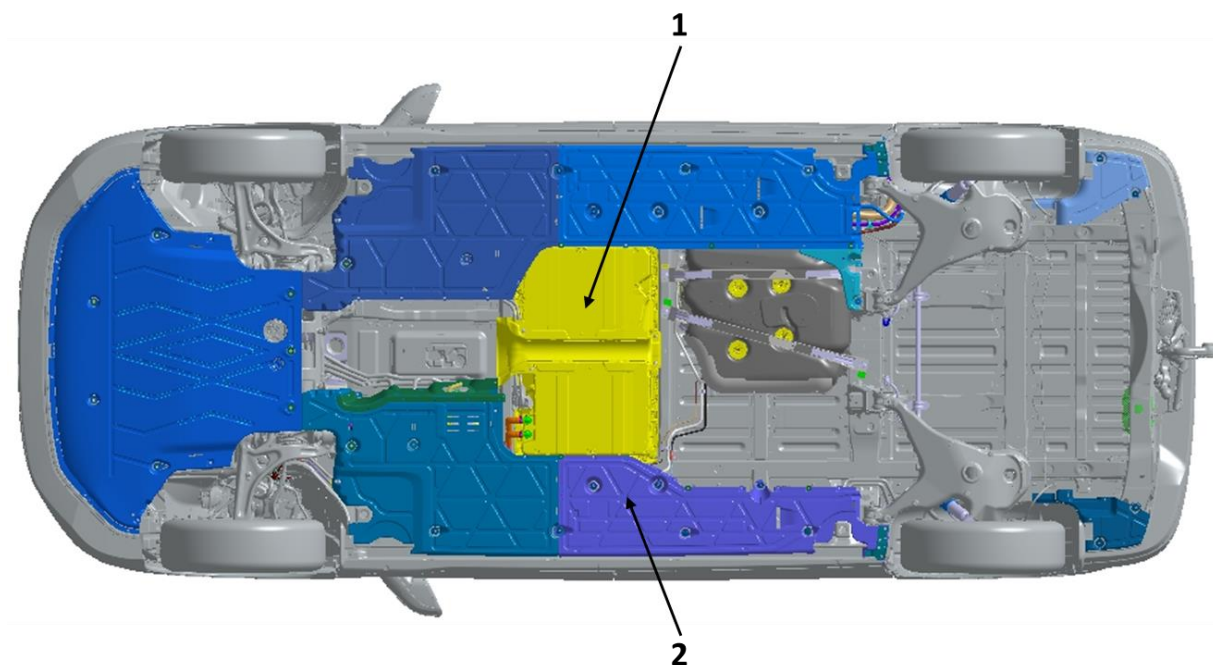

Fig. 1: Bottom view of high-voltage battery position

1 – lithium-ion high-voltage battery

2 – underbody cladding

#### Practical note

Modifications to the electric drive system are not permitted. Solutions regarding engine speed control are not possible. Modifications to the cooling system (radiator, air intake, air ducts etc.) are not permitted. Cooling air inlet surfaces must be kept clear.

**Warning note**

Special safety notes must be observed when working on electric vehicles. Failure to observe safety notes can result in a fatal electric shock.

**Information**

The required safety notes can be requested. Please contact us (see chapter 1.2.1 “Product and vehicle information for body builders”).

**Warning note**

Changes to the electrical drive system can lead to the system ceasing to function properly. Control of the vehicle may be lost.

**Warning note**

The voltage within the high-voltage vehicle electrics and high-voltage battery is life-threatening!

Touching damaged orange-coloured high-voltage wires and high-voltage battery may result in a fatal electric shock. The high-voltage system may also be active even if the ignition is switched off.

- Never carry out any work on the high-voltage vehicle electrics, orange-coloured high-voltage wires, high-voltage components or high-voltage battery. Work on the high-voltage system may only be performed by qualified specialist companies with appropriate accreditation to perform such work.
- Never modify, damage, dismantle or disconnect from the high-voltage system any of the orange-coloured high-voltage wires, high-voltage components or high-voltage battery.
- Work in close proximity to high-voltage components, high-voltage wires or high-voltage battery using machining, deforming or sharp-edged tools or heat sources, such as welding, soldering, hot-air or thermal bonding, may only be carried out if the voltage has been disconnected beforehand. The high-voltage battery cannot be de-energised. The high-voltage disconnection may only be performed by suitably qualified and trained specialist staff.
- If there is a fault in the high-voltage system, the drive is automatically deactivated where necessary, and a corresponding indicator may be displayed in the instrument cluster. Should this be the case, the drive will remain deactivated until the fault has been rectified by suitably qualified and trained specialist staff.
- The various Volkswagen policies must be observed when carrying out any work on the high-voltage system, including in particular on the orange-coloured high-voltage wires, the high-voltage components or the high-voltage battery.

## 5 Technical data

### 5.1 Build dimension drawings

Please refer to our build dimension drawings for the dimensions of the Multivan.

They are available for download in DXF, TIFF and PDF format at the CustomizedSolution portal of Volkswagen AG. All files (except PDFs) are packed as Zip archives. The files can be unpacked using Winzip (PC) or Ziplt (MAC).

#### Information

Current build dimension drawings are available for download from the CustomizedSolutionPortal of Volkswagen AG under the “Technical drawings” menu option.

## 5.2 Diagrams (foil templates)

Vehicle views of the Multivan in 1:20 scale are available for download in TIF, DXF and EPS format to help you create diagrams. All files are packed as Zip archives. The files can be unpacked using Winzip (PC) or Ziplt (MAC).

### Information

Current diagrams are available for downloading from the CustomizedSolutionPortal of Volkswagen AG under the “Foil templates” menu item.



## 5.3 Current flow diagrams

For detailed information about this topic, refer to the workshop manuals and circuit diagrams of Volkswagen AG.

### Information

Volkswagen AG workshop manuals and circuit diagrams can be downloaded from the Internet at **erWin\*** (Electronic Repair and Workshop Information from Volkswagen AG):  
<http://erwin.volkswagen.de/erwin/showHome.do>

\*Information system from Volkswagen AG, subject to payment

## 5.4 CAD models

As a registered body builder, you can receive 3-D data models in the formats CATIA V.5 and STEP for design purposes.

### Information

The available 3D data can be found on the CustomizedSolutionPortal of Volkswagen AG under "Technical information/CAD data"\*.

\*Registration required.

## 6 Weights (masses)

When ordering your vehicle, please note that the kerb weight increases when additional equipment is selected and the available payload capacity is therefore reduced.

Due to the continual changes to the base vehicle, all vehicle weights are available via the country-specific sales documents on the Internet or via the CustomizedSolution Portal ([www.customized-solution.com](http://www.customized-solution.com)).

We recommend determining the definitive kerb weight of the entire vehicle by weighing before the conversion.

For further questions, please contact your Volkswagen Commercial Vehicles dealer, your importer or our Customer Care (see chapter 1.2.1.1 "Contact in Germany", 1.2.1.2 "International contact").

### Practical note

For masses/dimensions, the following weight tolerances apply:

- 3% for vehicle classes M/N (except for special purpose vehicles).
- 5% for special purpose vehicles.

# 7 Homologation

## 7.1 Notes on homologation of modifications and conversions

### Amendments to legislation from 1 January 2022 Regulation (EU) 2018/858 EU and national (Art. 44 and Art. 45)

Affected: vehicle class M1

For complete vehicles completed ex works at the OEM, the following applies:

Complete vehicles that have been modified with add-ons/conversions after completion ex works and before initial registration must resubmit CO<sub>2</sub>/consumption values for the second stage.

These can be identified using the WLTP calculator in accordance with the available homologations.

There are ways for you to calculate weight changes. The mass in the ready-to-drive state must be taken into account. If individual values are not available for the respective conversion, a type approval can be applied for in coordination with the technical service / regulatory authority.

The vehicles are available ex works with full CoC \* in accordance with Euro 6d or Euro 6EB \*\* Light Duty in accordance with WLTP. The maximum permissible mass after the conversion can be determined using the WLTP calculator. Valid for the approved engine-gearbox variants (see offer for countries). The values for the maximum vehicle weights after the conversion depend on the drive/equipment combination of the base vehicle and the conversion type.

\*CoC Certificate of Conformity

\*\*Release expected from week 21/2024

#### Information

For all vehicles / engine-gearbox variants for which no values can currently be generated using the WLTP calculation tool, please contact your responsible technical service and check whether individual approval or multi-stage type approval is possible.

## 8 Listings

### 8.1 List of changes

Changes to the body builder guidelines compared to the data status of September 2023.

Chapter no.	Chapter heading	Scope of change
1	General information	
1.1	Introduction	
1.1.1	Concept of this Owner's Manual	
1.1.2	Means of representation	
1.1.3	Vehicle safety	
1.1.4	Operational safety	
1.1.5	Note on copyright	
1.2	General notes	
1.2.1	Product and vehicle information for body builders	
1.2.1.1	Contact in Germany	
1.2.1.2	International contact	
1.2.1.3	Electronic Repair and Workshop Information from Volkswagen AG (erWin)	
1.2.1.4	Genuine parts online ordering portal	
1.2.1.5	Online owner's manual	
1.2.1.6	European Type Approval (ETA) and Certificate of Conformity (CoC)	
1.2.1.7	Worldwide Harmonised Light Vehicles Test Procedure (WLTP)	
1.2.1.8	WLTP homologation for upgrades/conversions	
1.2.1.9	Manufacturer's declaration	
1.2.2	Body builder guidelines, consulting	
1.2.2.1	Letter of non-objection	Contact updated , wording adjusted.
1.2.2.2	Application for the letter of non-objection	
1.2.2.3	Legal entitlements	
1.2.3	Warranty and product liability of the body builder	
1.2.4	Ensuring traceability	
1.2.5	Badges	
1.2.5.1	Positions on rear of the vehicle	
1.2.5.2	Appearance of whole vehicle	
1.2.5.3	Non-Volkswagen badge	
1.2.5.4	Type plates	
1.2.6	Recommendations for vehicle storage	Information updated
1.2.7	Compliance with environmental rules and regulations	
1.2.8	Recommendations for inspection, maintenance and repair	
1.2.9	Accident prevention	
1.2.10	Quality system	
1.3	Planning bodies	
1.3.1	Selecting the base vehicle	Contact updated
1.3.2	Vehicle modifications	

Chapter no.	Chapter heading	Scope of change
1.3.3	Vehicle acceptance	
1.4	Special equipment	Contact updated
2	Technical data for planning	
2.1	Base vehicle	
2.1.1	Vehicle dimensions	
2.1.1.1	Multivan basic data	
2.1.2	Ramp angle and breakover angle	
2.2	Running gear	
2.2.1	Permitted weights and unladen weights	
2.2.2	Turning circle	
2.2.3	Authorised tyre sizes	
2.2.4	Modifications to axles	
2.2.5	Modifications to the steering system	
2.2.6	Brake system and brake control system ESC	
2.2.6.1	General notes	
2.2.6.2	Routing of additional cables	
2.2.7	Modification of springs, suspension mounting, dampers	
2.2.8	Wings and wheel housings	
2.3	Body-in-white	
2.3.1	Roof loads/vehicle roof	
2.3.1.1	Dynamic roof loads	
2.3.1.2	Static roof loads	
2.3.2	Modifications to the body-in-white	
2.3.2.1	Screw connections	
2.3.2.2	Welding work	
2.3.2.3	Welded connections	
2.3.2.4	Selection of welding process	
2.3.2.5	Spot welding	
2.3.2.6	Shielding gas hole spot welding	
2.3.2.7	Tacking	
2.3.2.8	Welding is not allowed	
2.3.2.9	Corrosion protection after welding	
2.3.2.10	Corrosion protection measures	
2.3.2.11	Planning measures	
2.3.2.12	Component design measures	
2.3.2.13	Coating measures	
2.3.2.14	Work on the vehicle	
2.4	Interior	
2.4.1	Modifications in the area of airbags	
2.4.2	Modifications in the area of seats	
2.4.2.1	Belt anchors	
2.4.3	Forced ventilation	
2.4.4	Acoustic insulation	
2.4.5	eCall Emergency System	
2.5	Electrics/electronics	
2.5.1	Lighting	

Chapter no.	Chapter heading	Scope of change
2.5.1.1	Vehicle lighting devices	
2.5.1.2	Adjusting headlights	
2.5.1.3	Special lights	
2.5.1.3.1	Rotating light, yellow light	
2.5.1.3.2	Roof-mounted turn signals	
2.5.2	Electrical system	
2.5.2.1	Electrical wiring/fuses	
2.5.2.2	Additional electrical circuits	
2.5.2.3	Retrofitting electrical devices	Chapter updated
2.5.2.4	Electromagnetic Compatibility	
2.5.2.5	Mobile communication systems	
2.5.2.6	CAN bus	
2.5.2.7	Current and signal take-off of vehicle electrical system potentials	
2.5.3	Electrical interface for special vehicles	
2.5.3.1	General information on the interfaces for special vehicles	Chapter updated
2.5.3.2	Customer-specific functional control unit (CFCU)	Chapter updated
2.5.3.3	Overview of Basic CFCU functions	Chapter updated
2.5.4	Vehicle battery	
2.5.5	Retrofitting alternators	Chapter on PR numbers updated
2.5.6	Driver assist systems	
2.5.7	Earth points	
2.6	Engine peripherals / drive train	
2.6.1	Engine / drive train components	
2.6.2	Drive shafts	
2.6.3	Fuel system	
2.6.4	Exhaust system	
2.6.4.1	Exhaust system (MAR) with PHEV	
2.6.5	SCR system	
2.6.5.1	Installation position of the AdBlue tank in the vehicle	
2.6.5.2	Filling opening of the AdBlue® tank	
2.7	Add-ons/units	
2.7.1	Roof carriers	
2.7.2	Towing brackets	
2.7.2.1	Maximum trailer weights	Designation of PR numbers adapted.
2.7.2.2	Retrofitting a trailer towing bracket	
2.8	Raising the vehicle	
3	Modifications to closed bodies	
3.1	Interior	
3.1.1	Safety features	
3.1.2	Retrofitting seats	
3.1.2.1	Installation of standard seats	
3.1.2.2	Installation of seats from after market suppliers	
4	Implementation of special bodies	
4.1	Vehicles for transporting persons with restricted mobility	
4.1.1	Base vehicle equipment	

Chapter no.	Chapter heading	Scope of change
4.1.2	Selection of steering rack	
4.1.3	Notes on conversion solutions for the wheelchair transporter	
4.1.4	Notes on installing manual operating devices	
4.1.5	Deactivating airbags	
4.2	Taxi/private hire car	
4.2.1	Preparation for taxis and private hire cars	Note added.
4.3	Plug-in hybrid electric vehicle (PHEV)	
4.3.1	High-voltage system	
5	Technical data	
5.1	Build dimension drawings	Chapter/link updated
5.2	Diagrams (foil templates)	Chapter/link updated
5.3	Current flow diagrams	
5.4	CAD models	Chapter/link updated
6	Weight tables	
7	Homologation	
7.1	Notes on homologation of modifications and conversions	Chapter revised in terms of content and format.
8	Listings	
8.1	List of changes	Changes entered
Last page	Address, mailroom slot	Vehicle designation and issue version updated



# Body builder guidelines

## The Multivan

Body builder guidelines

Subject to change without notice

Edition March 2024

Internet:

<https://www.volkswagen-nutzfahrzeuge.de>

<https://www.customized-solution.com>

Consulting for body builders in Germany is available from the listed address.

Volkswagen Commercial Vehicles

Brieffach 2949

Postfach 21 05 80

D-30405 Hannover