



Body builder guidelines

The ID Buzz (from model year 2022)



Table of contents

1 General information	5
1.1 Introduction	5
1.1.1 Concept of these guidelines	5
1.1.2 Means of representation	6
1.1.3 Vehicle safety	6
1.1.4 Operational safety	8
1.1.5 Note on copyright	8
1.2 General notes	9
1.2.1 Product and vehicle information for body builders	9
1.2.1.1 Contact in Germany	9
1.2.1.2 International contact	9
1.2.1.3 Electronic repair and workshop information from Volkswagen AG (erWin*)	10
1.2.1.4 Genuine Parts Online Ordering Portal*	10
1.2.1.5 Online Owner's Manual	10
1.2.1.6 European Type Approval (ETA) and EC Certificate of Conformity (CoC)	10
1.2.1.7 Worldwide Harmonised Light Vehicles Test Procedure (WLTP)	11
1.2.1.8 WLTP homologation for upgrades/conversions	11
1.2.1.9 Manufacturer's declaration	11
1.2.2 Body builder guidelines, consulting	12
1.2.2.1 Letter of non-objection	12
1.2.2.2 Application for the letter of non-objection	14
1.2.2.3 Legal entitlements	14
1.2.3 Warranty and product liability of the body builder	15
1.2.4 Ensuring traceability	15
1.2.5 Trademarks	15
1.2.5.1 Positions on rear of the vehicle	15
1.2.5.2 Appearance of overall vehicle	16
1.2.5.3 Non-Volkswagen trademarks	16
1.2.6 Recommendations for vehicle storage	16
1.2.7 Compliance with environmental rules and regulations	18
1.2.8 Recommendations for inspection, maintenance and repair	19
1.2.9 Accident prevention	19
1.2.10 Quality system	20
1.3 Planning bodies	21
1.3.1 Selecting the base vehicle	21
1.3.2 Vehicle modifications	22
1.3.2.1 Modifications to the underbody area of the high-voltage battery and the drive	23
1.3.2.2 Body side panels	26
1.3.2.3 Electrics	26
1.3.3 Vehicle acceptance	26
1.4 Optional equipment	27
2 Technical data for planning	28
2.1 Base vehicle	28
2.1.1 Vehicle dimensions	28
2.1.1.1. Basic data for ID Buzz Cargo	28
2.1.1.2. Overhang and breakover angle of ID Buzz Cargo	31
2.1.1.3. Basic data for ID Buzz	32
2.1.1.4. Overhang and breakover angle of ID Buzz	35

2.2 Running gear	36
2.2.1 Permitted weights and unladen weights	36
2.2.1.1 One-sided weight distribution	36
2.2.2 Turning circle	37
2.2.3 Authorised tyre sizes	37
2.2.4 Modifications to axles.....	37
2.2.5 Modifications to the steering system	37
2.2.6 Brake system and brake control system	37
2.2.6.1 General information	37
2.2.6.2 Routing additional lines along the brake hoses/brake lines.....	37
2.2.7 Modification of springs, suspension mounting, dampers.....	38
2.2.8 Wings and wheel housings.....	38
2.3 Body-in-white	39
2.3.1 Roof loads	39
2.3.1.1 Dynamic roof loads.....	39
2.3.1.2 Static roof loads	39
2.3.2 Modifications to the body-in-white.....	39
2.3.2.1 Screw connections.....	39
2.3.2.2 Welding work.....	40
2.3.2.3 Welded connections	43
2.3.2.4 Selection of welding process.....	43
2.3.2.5 Spot welding	43
2.3.2.6 Shielding gas hole spot welding	44
2.3.2.7 Tacking.....	45
2.3.2.8 Welding is not allowed	45
2.3.2.9 Corrosion protection after welding	45
2.3.2.10 Corrosion protection measures.....	46
2.3.2.11 Planning measures	46
2.3.2.12 Component design measures.....	47
2.3.2.13 Coating measures	47
2.3.2.14 Work on the vehicle.....	47
2.4 Interior	48
2.4.1 Modifications in the area of airbags.....	48
2.4.2 Modifications in the area of seats.....	48
2.4.2.1 Belt anchors	48
2.4.3 Forced ventilation.....	49
2.4.4 Acoustic insulation	49
2.4.5 eCall Emergency System	49
2.5 Electrics/electronics.....	50
2.5.1 Lighting	50
2.5.1.1 Vehicle lighting devices	50
2.5.1.2 Adjusting the headlights.....	50
2.5.2 Vehicle electrical system.....	51
2.5.2.1 Electrical wiring / fuses / in reference to the 12 V electrical system	51
2.5.2.2 Additional circuits	52
2.5.2.3 Fuse carrier with emergency cut-out connection	53
2.5.2.4 Electromagnetic compatibility	54
2.5.2.5 Mobile communication systems	54
2.5.2.6 CAN bus	55
2.5.3 Electrical interface for special vehicles	57

2.5.3.1	General notes on the interface for special vehicles	57
2.5.3.2	Electrical interface for special vehicles / electrical terminal strip IS1*	58
2.5.4	Vehicle battery – 12-V vehicle electrical system battery.....	59
2.5.4.1	230 V inverter.....	59
2.5.5	Driver assist systems.....	59
2.5.6	Earth points.....	61
2.6	Battery and drive for electric vehicle.....	62
2.6.1	High-voltage system	63
2.6.2	Charging the high-voltage battery.....	66
2.7	Add-ons/units.....	68
2.7.1	Roof carriers	68
2.7.2	Towing brackets	69
2.7.2.1	Maximum trailer weights	69
2.7.2.2	Retrofitting a trailer towing bracket	69
2.8	Raising the vehicle	70
3	Modifications to closed bodies	71
3.1	Interior	71
3.1.1	Safety features	71
3.1.2	Retrofitting and removal of standard seats	72
3.1.2.1	Seat-occupied recognition system	72
3.1.2.2	Installation of aftermarket product seats or use of standard seats deviating from the standard seating.....	73
3.1.3	Changes to the roof of the ID Buzz / ID Buzz Cargo	74
3.1.4	Subsequent roof cut-outs	74
3.1.5	Side wall cut-outs	76
3.1.6	Subsequent installation of windows	76
3.1.7	Modifying the partition wall/forced ventilation	77
3.1.8	Lashing rails.....	78
3.1.8.1	Retrofitting lashing rails	78
3.1.9	Universal floor	79
3.1.10	Shelf installation / workshop installation.....	80
4	Implementations of special bodies.....	82
4.1	Motor vehicles for the transport of persons with disabilities (KMP)	82
4.1.1	Base vehicle equipment.....	82
4.1.2	Notes on installing manual operating devices for the foot brake	82
4.1.3	Deactivating the airbag/belt tensioner system.....	82
5	Technical data	83
5.1	Build dimension drawings	83
5.2	Diagrams (foil templates).....	84
5.3	Current flow diagrams	85
5.4	CAD models	86
6	Weights (masses).....	87
7	Homologation.....	88
7.1	Notes on homologation of modifications and conversions	88
8	Listings	89
8.1	List of changes	89

*Electronic Stability Control

1 General information

1.1 Introduction

These body builder guidelines provide body builders with important technical information which must be complied with when planning and manufacturing a body for road safety and operational reliability. The add-on, body, installation or conversion work required for this is referred to below as “body activities”.

Due to the vast number of body builders and types of conversion, it is not possible for Volkswagen AG to predict all possible changes which may occur due to the body activities, e.g. with regard to driving properties, stability, weight distribution, centre of gravity of the vehicle and its handling characteristics. Therefore, Volkswagen AG does not accept any liability for accidents or injuries arising from changes of this kind made to its vehicles, especially if the changes have a negative effect on the vehicle as a whole. As a result, Volkswagen AG only accepts liability for its own design, production and instruction services. The body builder itself is obliged to ensure that its body activities are not faulty in themselves, and also that they cannot result in defects or dangers on the vehicle as a whole. The body builder must also ensure the conformity of the body activities with the respective and applicable laws (in particular approval and registration processes). The body builder itself is liable in the event that this obligation is violated.

These body builder guidelines are intended for professional body builders. As a result, these body builder guidelines assume corresponding background knowledge. Note that some work (e.g. welding on load-bearing parts) is only allowed to be performed by appropriately qualified personnel. This requirement exists in order to avoid risks of injury and to achieve the quality needed in the body activities.

1.1.1 Concept of these guidelines

The following body builder guidelines are divided into 8 chapters so that you can find information rapidly:

1. Introduction
2. Technical data for planning
3. Modifications to closed bodies
4. Implementations of special bodies
5. Technical data
6. Weights (masses)
7. Notes on homologation of modifications and conversions
8. Listings

Information

For more information, see chapter 1.2.1.1 “Contact” and chapter 1.2.2 “Body builder guidelines, consulting”.

It is essential that the limit values selected in chapter 2 “Technical data for planning” are complied with and are used as the basis for planning.

1.1.2 Means of representation

The following means of representation are used in these body builder guidelines:

Warning note

A danger note draws your attention to possible accident or injury risks to which you or other persons might be exposed.

Environmental note

An environmental note provides you with information about environmental protection.

Practical note

This note draws your attention to the risk of possible damage to the vehicle, as well as to regulations and provisions to be observed.

Information

This note indicates additional information.

1.1.3 Vehicle safety

Warning note

Before installing external add-ons or mechanical units, it is essential that you read the chapters in these body builder guidelines that are related to installation, as well as corresponding chapters in the instructions and information for the suppliers' mechanical units and in the detailed owner's manual for the base vehicle. Otherwise you will not be able to recognise dangers, and might expose yourself or others to danger.

We recommend that you use parts, mechanical units, conversion parts or accessories that have been tested by Volkswagen AG for the corresponding vehicle type. Have the vehicle's safety checked immediately if non-recommended parts, mechanical units, conversion parts or accessories are used.

Warning note

Special safety notes must be observed when working on electric vehicles. Failure to observe safety notes can result in a fatal electric shock.

Information

The required safety notes can be requested. Please contact us (see chapter 1.2.1 “Product and vehicle information for body builders”).

Practical note

It is essential that you comply with European vehicle approval or UN ECE R regulations, as well as national registration regulations and also technical vehicle regulations. This is because body activities on the vehicle can alter the vehicle type under registration regulations and the operating permit may be invalidated.

This applies in particular to:

- modifications which change the vehicle type approved in the operating permit
- modifications which might be expected to endanger road users or
- modifications which impair the exhaust or noise emissions characteristics.

1.1.4 Operational safety

Warning note

Incorrect interventions in electronic components and their software may result in these no longer functioning. Due to the networking of electronics, systems that were not modified can be affected.

Malfunctions to the electronics can significantly impair the operational safety of the vehicle.

Have work on or modifications to electronic components performed by a qualified specialist workshop which has the necessary specialist knowledge and tools for performing the necessary work.

Volkswagen AG recommends a Volkswagen AG customer service workshop for this purpose.

Service by a qualified specialist workshop is essential, in particular for safety-relevant work and work on safety-relevant systems.

Some safety systems only operate when the engine is running. Therefore, do not switch the engine off when driving.

1.1.5 Note on copyright

The texts, pictures and data contained in these body builder guidelines are subject to copyright.

This also applies to editions on CD-ROM, DVD or other media.

1.2 General notes

The following pages contain technical guidelines for body builders and equipment fitters on the design and assembly of bodies. The body builder guidelines must be strictly adhered to when performing any modifications to the vehicle. The current version of the German edition of the body builder guidelines is the exclusive authority for the most up-to-date information.

This also applies to legal claims. Should the body builder guidelines include references to legal regulations, then no guarantee can be provided for the completeness and correctness of this content, or that it is up-to-date. Country-specific features can vary.

1.2.1 Product and vehicle information for body builders

1.2.1.1 Contact in Germany

If you have questions concerning vehicle models from Volkswagen Commercial Vehicles, you can contact us via the internet portals of Volkswagen AG (www.customized-solution.com) or via one of the following methods:

Free hotline (from a German landline)	00 800-2878 66 49 33 (00 800-CUSTOMIZED)
Contact (email)	customizedsolution@volkswagen.de
Personal contacts	https://www.customized-solution.com/de/de/service-informationen/kundenbetreuung

1.2.1.2 International contact

Please contact the body builder's support personnel at the responsible importer for technical advice relating to Volkswagen Commercial Vehicles models and as a point of contact for conversions.

To find the contact person responsible for you, please register on the Volkswagen AG CustomizedSolution portal (<https://www.customized-solution.com>).

Help is available for the registration option using the "Help" menu option.

International hotline	00-800-2878 66 49 33 (00-800-CUSTOMIZED)
Email	customizedsolution@volkswagen.de
Personal contacts	https://www.customized-solution.com/de/de/service-informationen/kundenbetreuung or https://dealerportal.vw-group.com/jctumbau/web/international/faq

1.2.1.3 Electronic repair and workshop information from Volkswagen AG (erWin*)

Body builders can access repair and workshop information, e.g.:

- Current flow diagrams
- Workshop Manuals
- Maintenance
- Self-study Programmes

via the Electronic Repair and Workshop Information System from Volkswagen AG (erWin*).

<http://erwin.volkswagen.de/erwin/showHome.do>

Body builders with Integrated or PremiumPartner status are eligible for discounted annual licences that can be requested in the CustomizedSolution Portal under My CustomizedSolution Portal/Requirements/Planning and Development.

Body builders in export with the Partner status receive information in this regard from their point of contact at the importer.

*Information system, subject to payment

1.2.1.4 Genuine Parts Online Ordering Portal*

For the purchase of spare parts and for the research of Volkswagen Genuine Parts, our latest parts catalogues are available on the Internet in the “Genuine Parts Online Ordering Portal”:

<http://www.partslink24.com>

*Information system, subject to payment

1.2.1.5 Online Owner’s Manual

Detailed information about the functions and handling of your vehicle can be found in your Owner’s Manual which is enclosed with your vehicle ex-works. In addition to the hard copy of the Owner’s Manual, the following link and VIN number of the vehicle can be used to receive the Owner’s Manual in electronic form.

https://userguide.volkswagen.de/public/vin/login/de_DE

1.2.1.6 European Type Approval (ETA) and EC Certificate of Conformity (CoC)

Directive (EU) 2018/858 of the European Parliament establishes the standard for the approval of motor vehicles and their trailers, and of systems, components and separate technical units intended for such vehicles.

Provisions were also adopted in these guidelines for the approval of vehicles produced in several stages: the multi-stage approval process. Accordingly, each manufacturer involved in the construction of a vehicle is itself responsible for the approval of modified or added scopes in its production stage.

The manufacturer may choose one of the four following methods:

- EU type approval (ETA)
- EU type approval for small series
- National small series type approval
- Individual approval

CoC = Certificate of Conformity. A document that verifies the conformity of certain goods – and therefore also of vehicles and bodies – in accordance with the recognised (international) standards. The purpose of this EC Certificate of Conformity is to facilitate the approval of goods on international markets. As a result, the document is needed above all in import and export as part of the customs clearance procedure.

The manufacturer, the owner of an EU type approval or EU small series type approval, is obliged to provide a Certificate of Conformity with every vehicle which corresponds to an approved type. If you are planning to apply multi-stage type approval, an agreement must be concluded in accordance with the 2018/858/EU regulation.

1.2.1.7 Worldwide Harmonised Light Vehicles Test Procedure (WLTP)

New consumption values/ranges calculated in accordance with the new WLTP standards apply from September 2017 for new passenger cars entering the market and from September 2018 for new light commercial vehicles entering the market.

As of 1 September 2018, certified WLTP measurements must be available for all newly registered passenger cars. The rule enters into force for larger light commercial vehicles one year later on 1 September 2019. 28+6 markets in Europe are affected by the WLTP.

WLTP stands for Worldwide Harmonised Light Vehicles Test Procedure. This is a worldwide standardised testing procedure for determining fuel consumption / electric range and exhaust emissions.

It is replacing the NEDC (New European Driving Cycle) test procedure that has been in force since 1992.

Unlike the NEDC, the WLTP takes into account individual special equipment and conversion solutions for weight, aerodynamics, electrical system requirements (no-load current) and rolling resistance which have an impact on the fuel consumption / electric range and exhaust emissions. This includes, in particular, changes that result in a larger end face, a different radiator inflow area, a higher kerb weight for the vehicle or changes to the tyre size or the rolling resistance. Special equipment that consumes power, such as the air conditioning system or seat heating, still remains switched off for the duration of the test procedure.

Before initial approval, conversions or add-ons where WLTP is relevant can be made if they are approved by way of an individual approval or multi-stage type approval.

The Volkswagen type approval can be used for the multi-stage type approval for vehicles with conversions or add-ons that remain within the ISC parameters / maximum technical specifications for add-on parts. If the add-on or conversion is outside the ISC parameters / maximum technical specifications defined by the manufacturer for add-on parts, the body builder must demonstrate compliance with the exhaust gas emissions requirements / electric range.

Information about the ISC parameters / maximum technical specifications for add-on parts can be found on the Volkswagen CustomizedSolution portal. Please ask your technical service/test centre for advice if you have questions about alternatives.

To determine the consumption values of converted new vehicles in compliance with the WLTP procedure and to obtain a WLTP certification, the “WLTP Conversion Calculator” is available to you.

You can find more information as a Registered Converter on the CustomizedSolution portal / WLTP:

Germany / International: <https://www.customized-solution.com>

1.2.1.8 WLTP homologation for upgrades/conversions

For information on this topic, see chapter 7

1.2.1.9 Manufacturer's declaration

We issue a manufacturer's declaration for the base vehicle for the following scopes:

- Load increases and reductions
- Electromagnetic compatibility (EMC)
- Dangerous goods transport ADR 2017 for vehicles EX/II (explosive substances)

Please contact our customer support:

nutzfahrzeuge@volkswagen.de

1.2.2 Body builder guidelines, consulting

The body assembly guidelines define the requirements for body builders and coachwork specialists for construction and assembly of custom body-related parts and conversions for Volkswagen Commercial Vehicles.

The body builder guidelines must be strictly adhered to when performing any modifications to the vehicle.

The statutory requirements, technical vehicle regulations and guidelines stated in the Directive are not comprehensive. When making modifications to vehicles, all applicable statutory requirements and all technical vehicle regulations and guidelines must be observed. The work safety regulations of the trade association and the Machinery Directive must be observed.

Ensure that no modification adversely affects the functional reliability and safety of the running gear, the body or the electric system. Modifications must only be performed by qualified specialists and in accordance with the generally acknowledged rules of the automotive industry.

Prerequisites for modifications to used vehicles:

The vehicle shall be in a good overall condition, i.e. structural parts such as longitudinal and cross members, pillars etc. shall not be corroded to such an extent that structural stability might be adversely affected.

Vehicles whose modifications might affect the validity of the general certificate of roadworthiness must be presented to an authorised testing centre for approval. It is recommended to clarify in advance with the relevant authority whether approval is required. Please contact us in case of inquiries for proposed modifications.

When inquiring about planned modifications, please enclose two sets of design drawings of the complete scope of the modification, including weights, centre of gravity and dimensions, which also clearly show how the body is attached to the chassis. Please also provide information about the intended operating conditions of the vehicle.

If bodies comply with the present body builder guidelines, no additional approval by Volkswagen AG is required for the presentation of the vehicle at the relevant authority examining roadworthiness.

1.2.2.1 Letter of non-objection

Volkswagen AG does not issue body approvals for non-Volkswagen bodies. It merely provides body builders with important information and technical specifications for dealing with the product in these guidelines. As a result, Volkswagen AG recommends that all work should be carried out on the base vehicle and the body in accordance with the current Volkswagen body builder guidelines applicable to the vehicle in question.

Volkswagen AG does not recommend body activities which

- are not conducted according to these Volkswagen body builder guidelines
- exceed the gross vehicle weight rating
- exceed the gross axle weight rating.

Volkswagen AG issues letters of non-objection on a voluntary basis, as follows:

The assessment conducted by Volkswagen AG is exclusively based on the documents submitted by the body builder which is carrying out the modifications. Only the expressly designated scopes are tested and ensured and essentially compatible.

The safety certificate relates to the presented overall vehicle, and not

- to the design of the overall body,
- its functions or
- the planned use.

Safety is only provided if the design, production and installation are carried out by the body builder performing the modifications in accordance with the state of the art and in accordance with the applicable body builder guidelines of Volkswagen AG – and assuming any deviations from these guidelines have been declared to be technically safe. The letter of non-objection does not release the body builder who is performing the modifications from its responsibility for the product, or from its obligation to carry out its own calculations, tests and a trial of the entire vehicle in order to ensure that the operational safety,

road safety and driving properties of the overall vehicle it has manufactured are acceptable. Accordingly, it is necessary to ensure that the body builder exclusively accepts its responsibility for ensuring that its body activities are compatible with the base vehicle as well as the operational and road safety of the vehicle. It is expressly stated that the letter of non-objection from Volkswagen AG does not represent a technical approval for the investigated changes.

In the course of assessment of a presented vehicle, an assessment report is written as a means of obtaining a letter of non-objection (LONO report).

The following assessment results are possible:

- Classified as “safe”
If the overall vehicle is classified as “safe”, the Sales department can subsequently issue the LONO certificate.
- Classified as “not safe”
Classification as “not safe” in the individual categories:
 - + base vehicle configuration
 - + impairment of the base vehicle and possibly
 - + sole body item

leads to a corresponding classification of the overall vehicle. This means no LONO certificate can be issued initially.

In order for a not-safe classification to be resolved, the safety certificate report states the necessary change for each item in question. In order for the letter of non-objection to be obtained, these points will have to be addressed by the body builder and documented in a clearly comprehensible manner in a report along the same lines as the LONO report. On the basis of this detailed report, it is possible for the desk-review assessment to be completed with a positive result.

Depending on the defective points, it may be necessary not only to provide documentation of the defect resolution but also for the vehicle from the first inspection to be presented again. The first report indicates if it will be necessary for a new assessment to be carried out on the vehicle.

The assessment report may also contain “notes/recommendations”.

Notes/recommendations are technical remarks which do not have any effect on the letter of non-objection. They should be regarded as advice and suggestions for further consideration to support the continuous improvement of the final product for the customer.

In addition, “notes/recommendations solely relating to the conversion” can also be formulated. The notes and recommendations stated as “solely relating to the body/conversion” must be dealt with and documented before the vehicle can be included in the body builder portal.

Practical note

Country-specific laws, directives and approval regulations shall be observed!

1.2.2.2 Application for the letter of non-objection

Before starting any work on the vehicle, auditable technical documentation and drawings must be submitted to the responsible department as part of the letter of non-objection evaluation (see 1.2.1 “Product and vehicle information for body builders”).

Speedy handling of the request requires:

- Documents preferably in standardised digital formats (e.g. PDF, DXF, STEP)
- Technical data and documentation should be complete

The following details must be included:

- Vehicle type
- + Vehicle design
- + Wheelbase
- + Frame overhang
- Vehicle identification number (if already available)
- Any deviations from these body builder guidelines must be indicated on all documentation
- Axle load calculation
- All data about dimensions, weight and centre of gravity (weighing certificate)
- Special operating conditions (e.g. poor road conditions, extreme dust, high altitude, or ambient temperature extremes)
- Certificates (e-registration, seat tensile test)
- Attachment of the body on the vehicle
- Type of fixation for the body or add-ons to the vehicle frame (e.g. bolted connections)
- + Positioning
- + Type
- + Size
- + Number
- + Property class
- Type of fixation for the body or add-ons to the vehicle frame (bolting, bonding, welding)
- Photographic documentation of the conversion
- All documents must clearly correlate with the conversion (e.g. drawings marked with allocated numbers).
- General (functional) description of deviations from the series vehicle, or added components.
- Electric wiring diagram
- + Details of the consumption of additional electrical equipment.

Complete documentation avoids the need for clarification queries and accelerates the processing.

1.2.2.3 Legal entitlements

- There is no legal entitlement for a letter of non-objection to be issued.
- Due to ongoing technical development and the information derived from this, Volkswagen AG is entitled to refuse a letter of non-objection even if a comparable certificate had been issued formerly.
- The letter of non-objection can be restricted to individual vehicles.
- The subsequent issue of a letter of non-objection may be refused for vehicles that have already been completed or delivered.
- The body builder is solely responsible for:
 - + the function and compatibility of its body activities with the base vehicle.
 - + road safety and operational reliability.
 - + all body activities and installed parts.

1.2.3 Warranty and product liability of the body builder

UN ECE Regulation No. 155 for vehicle cyber security and UN ECE Regulation No. 156 for vehicle software updates apply to all new vehicle types from the middle of 2022 and to all new vehicle registrations from the middle of 2024; these contain new requirements for automotive cyber security and updates.

Insofar as modifications are made to the vehicle, the body builder shall also ensure that these regulations are applied and complied with. The body builder's or equipment fitter's warranty conditions apply to the body builder's or equipment fitter's scope of supply. Therefore, warranty claims associated with complaints to this scope of supply cannot be made under the warranty conditions applicable to Volkswagen Commercial Vehicles.

Defects of bodies, installations and conversions provided by third parties as well as defects of the vehicle caused by the said bodies, installations or conversions are excluded from the Volkswagen warranty and also from the Volkswagen paint and body warranty. This also applies to accessories which were not installed and/or supplied by the vehicle manufacturer.

The body builder or equipment fitter is solely responsible for the design and assembly of bodies and the execution of conversions.

All modifications must be documented by the body builder or equipment fitter.

The body builder is responsible for ensuring that all modifications it performs comply with the technical vehicle regulations, specifications and standards that apply in the countries of registration.

Due to the multitude of modifications and diversity of operating conditions, the information provided by Volkswagen AG is subject to the reservation that modified vehicles are not tested by Volkswagen AG. Modifications may affect the properties of the vehicle.

For reasons of liability, the body builders or fitters must provide the following information in writing to their customers:

"Due to the modifications* to your Volkswagen Commercial Vehicles base vehicle, the properties of your base vehicle may have changed. Please understand that Volkswagen AG does not assume any liability for any negative effects resulting from the modifications* to the vehicle."

In individual cases, Volkswagen AG reserves the right to demand evidence of the information being passed on to the customer.

No general legal entitlement for the approval of a body modification exists, even if such approval was previously granted.

If bodies comply with the present guidelines, no additional approval by Volkswagen AG is required for the presentation of the vehicle at the relevant authority examining roadworthiness.

* At this point, the term "modification" may be substituted by a more precise description of the work performed, e.g. by "camping equipment installation", "wheelbase extension".

1.2.4 Ensuring traceability

Body dangers only detected after delivery can mean that subsequent measures in the market will be necessary (customer information, warning, call-back). To make these measures as efficient as possible, it is necessary to be able to trace the product after delivery. For this purpose, and in order to be able to use the central vehicle register (CVR) operated by the Federal Motor Transport Authority or comparable registers abroad for tracing the affected vehicle keepers, we strongly recommend that body builders should store the serial number / identification number of their body linked to the vehicle identification number (VIN) of the base vehicle in their databases. For this purpose, it is also recommended that customers' addresses are stored and that subsequent owners are provided with a means of registration.

1.2.5 Trademarks

VW badges and VW emblems are trademarks of Volkswagen AG. VW badges and VW emblems are not allowed to be removed without authorisation, or to be attached in a different location.

1.2.5.1 Positions on rear of the vehicle

VW badges and VW emblems which are enclosed in the delivery must be fitted in the location intended by Volkswagen.

1.2.5.2 Appearance of overall vehicle

If the vehicle does not correspond to the appearance and the quality requirements set by Volkswagen AG, then Volkswagen AG reserves the right to request removal of the Volkswagen AG trademarks.

1.2.5.3 Non-Volkswagen trademarks

Non-Volkswagen badges are not allowed to be attached next to Volkswagen badges.

1.2.6 Recommendations for vehicle storage

Extended storage times cannot always be avoided. The following measures are recommended to ensure that vehicle quality is not affected by long-term storage:

Carry out the following when the vehicle is delivered:

- Check weekly for aggressive deposits (e.g. bird droppings, industrial deposits) and clean if necessary.
- 12-V battery: Determine the SoC* and, if necessary, complete the battery care programme (see the instructions “Carry out no later than every three months”).
- High-voltage battery: Read the state of charge in the instrument cluster.
If the charging indicator is in the red area: This means: $\leq 10\%$ or $< 1/4$ or < 50 km (depending on the display).
Charge the high-voltage battery until the display shows a maximum of half full.
- Set the tyre pressure to 3.4 bar (not the spare wheel).
- Open all front air outlets in the dash panel, set the blower to maximum and run for one minute.
- Remove any paper and other objects from the storage compartments and surfaces in the vehicle interior (dash panel, seats, luggage space) except for items that serve to protect the surfaces.
- If fitted, roll in the luggage compartment cover and the sun blinds.
- In addition, for new vehicles: Correct the position of the transport protective hoods if necessary.
- Record the date of delivery as a reference for all vehicle care measures.

*State of Charge

Carry out after no longer than six weeks:

- For vehicles stored without a solar panel:
Battery care programme (see “Carry out after no longer than three months”).
Do not disconnect the battery to do so!

Carry out after no longer than three months:

- Carry out braking to remove disc rust.
When storing vehicles without solar panels: Complete the battery care programme.
Do not disconnect the battery to do so!
- No battery status display in the dash panel insert:
Measure the open-circuit voltage of the 12-V battery two hours after the last electrical equipment was active.
 - a) At an open-circuit voltage between 11.6 V and 12.5 V: Fully charge immediately.
 - b) If the open-circuit voltage is < 11.6 V: Mark and fully charge the defective battery.
- The totally discharged battery must be replaced before the vehicle is handed over to the customer.

Practical note

To determine the exact residual capacity of the 12-V battery, please proceed in accordance with the test conditions in the Workshop Manual.

Carry out after no longer than six months:

- For vehicles stored with a solar panel:
Carry out the battery maintenance programme (see “Carry out after no longer than three months”).
Do not disconnect the battery!

Information

You can find further information about vehicle storage in the following documents:

- Owner’s Manual
- Vehicle care programme

1.2.7 Compliance with environmental rules and regulations

Environmental note

The following principles of environmentally friendly design and material selection should be followed right from the planning stage of fitted components or bodies, and the statutory requirements in the EU Directive on End-of-Life Vehicles 2000/53/EC should also be taken into account.

The body builder is responsible for ensuring that all modifications it performs comply with the environmental regulations, specifications and standards that apply in the countries of registration and sale. These may go beyond the existing prerequisites of the base vehicle and are the responsibility of the body builder.

The body builder must ensure that add-ons and bodies (conversions) comply with all applicable environmental rules and regulations, especially, but not only, EU directive 2000/53/EC concerning end-of-life vehicles and the REACH Regulation (EC) 1907/2006 relating to restrictions on the marketing and use of certain dangerous substances and preparations ("low flammability" and certain flame-retardant agents).

The registered keeper must keep all assembly documentation concerning the modification and hand it over together with the vehicle to the dismantler. This ensures that modified vehicles are processed in compliance with environmental rules and regulations at the end of their life cycle.

Materials which represent a potential risk such as halogen additives, heavy metals, asbestos, CFCs and chlorinated hydrocarbons shall be avoided.

- EU Directive 2000/53/EC must be adhered to.
- Preferably, materials which allow valuable substance recycling and closed material cycles shall be used.
- The material and production process shall be selected so that only low amounts of easily recyclable waste are generated.
- Plastics shall only be used where these offer advantages in terms of cost, function or weight.
- In the case of plastics, especially composite materials, only mutually compatible substances from one material family may be used.
- With regard to components that are relevant for recycling, the number of plastic types used shall be kept as low as possible.
- It is necessary to check whether a component can be manufactured from recycled material or with recycled additives.
- Care shall be taken to ensure that recyclable components can be removed easily, e.g. by means of snap-lock connections, predetermined breaking points, good accessibility, use of standard tools.
- Simple, environmentally friendly removal of the fluids shall be ensured by means of drain plugs etc.
- Wherever possible, the components shall not be painted or coated; instead, dyed plastic parts shall be used.
- Components in areas at risk of accident shall be designed to be tolerant of damage, repairable and easy to exchange.
- All plastic parts shall be identified according to the VDA material sheet 260 ("Components of motor vehicles; Identification of materials"), e.g. "PP-GF30R".

1.2.8 Recommendations for inspection, maintenance and repair

A service schedule outlining inspection and servicing work must be provided for the modifications performed by the body builder or accessories fitter. These instructions or schedules must include the maintenance and inspection intervals as well as the required operating fluids and materials and the spare parts. It is also important to specify parts and components with a limited service life which are to be checked at regular intervals in order to ensure service reliability and timely replacement where required.

This should be supported by a Workshop Manual including tightening torques, setting tolerances and other relevant specifications.

Special tools, including their source of supply, must also be stated.

Body builders / fitters must also state which work may only be performed only by themselves or by their authorised workshops.

If the body builder's or accessory fitter's scope of supply includes electric, electronic, mechatronic, hydraulic or pneumatic systems, then current flow diagrams and diagnosis routines or similar documentation facilitating a systematic search for faults should be provided.

Please observe the Volkswagen AG owner's manual for the inspection, maintenance and repair of the base vehicle.

Please only use brake fluids and engine oils approved by Volkswagen for your vehicle.

More information about brake fluids and engine oils can be found in the operating manual for your vehicle:

https://userguide.volkswagen.de/public/vin/login/de_DE (see also chapter 1.2.1.5 "Online Owner's Manual").

1.2.9 Accident prevention

Body builders shall ensure that the bodies comply with applicable legal rules and regulations as well as all regulations regarding work safety and accident prevention. All safety rules and the information material provided by accident insurance providers shall be observed.

All technically feasible measures must be taken to prevent unsafe operation.

Country-specific laws, directives and approval regulations must be observed.

The body builder is responsible for the compliance with these laws, rules and regulations.

For further information about commercial freight traffic in the Federal Republic of Germany please contact:

P.O. box address	Berufsgenossenschaft für Fahrzeughaltungen Fachausschuss "Verkehr" Sachgebiet "Fahrzeuge" Ottenser Hauptstrasse 54 D-22765 Hamburg
Telephone	+49 (0) 40 39 80 - 0
Fax	+49 (0) 40 39 80-19 99
Email	info@bgf.de
Home page	http://www.bgf.de

1.2.10 Quality system

Worldwide competition, increased quality requirements placed on the overall ID Buzz product by customers, national and international product liability legislation, new organisational forms and increasing cost pressure mean that effective quality assurance systems are required in all areas of the automotive industry.

The requirements of a quality management system of this kind are described in DIN EN ISO 9001.

For the reasons stated above, Volkswagen AG strongly recommends that all body builders should set up and maintain a quality management system with the following minimum requirements:

Definition of responsibilities and authorisations including organisational plan.

- Description of the processes and procedures.
- Appointment of a quality management representative.
- Performing contract and build feasibility checks.
- Performing product checks based on specified instructions.
- Regulating the handling of faulty products.
- Documentation and archiving of test results.
- Ensuring the quality records of employees are up to date.
- Systematic monitoring of test equipment.
- Systematic material and parts identification.
- Performing quality assurance measures at the suppliers.
- Ensuring the availability of process, working and test instructions, and that they are up to date, in the departments and in the workplace.

1.3 Planning bodies

Practical note

In addition to a user and maintenance friendly design (see chapter 2.3.2.10 “Corrosion protection measures”), the right choice of materials and therefore observance of corrosion protection measures are important during the planning of bodies.

1.3.1 Selecting the base vehicle

The base vehicle needs to be selected carefully to ensure safe usage in the respective field.

When planning, please consider the following for the use in question:

- Wheelbase
- Engine/gearbox
- Final drive ratio
- Gross vehicle weight rating
- Seating version (number and arrangement)
- Electrical scopes (e.g. interior lighting, vehicle battery, (see chapter 2.5 “Electrics / Electronics”).

Practical note

Before carrying out body building or conversion measures, the supplied base vehicle should be checked with regard to the fulfilment of applicable requirements.

You will find more information on the available ID Buzz versions and body versions in the sales documentation. Please contact us (see chapters 1.2.1.1 “Contact in Germany” and 1.2.1.2 “International contact”).

Information

On the Volkswagen AG homepage, you can put your vehicle together with the configurator and view the available optional equipment:

<https://www.volkswagen-nutzfahrzeuge.de/de/modelle.html>

1.3.2 Vehicle modifications

Before starting work on the body, the body builder should check whether the vehicle is suitable for the planned body.

Build dimension drawings, product information and technical data can be obtained from the relevant department or via the communication system for the planning of bodies (see chapter 1.2.1.1 “Contact in Germany”, 1.2.1.2 “International contact” and 1.2.2 “Body builder guidelines, consulting”).

Furthermore, the special equipment available from the factory should be noted (see chapter 1.4 “Special equipment”).

Vehicles delivered from the factory comply with European directives and the national laws (except for some vehicles for countries outside Europe).

The vehicles also need to meet the European directives and the national laws after the modifications have been made.

Practical note

Sufficient space must be provided in order to guarantee the function and operating safety of the components.

Modifications to the noise encapsulation can have effects which are relevant to registration.

Modifications to the cooling and heating system and their components are not permitted.

Warning note

Do not modify the steering, brake or drive system!
Modifications to the steering, brake or drive system can result in these systems no longer working correctly and failing. This may result in the driver losing control of the vehicle and causing an accident.

Practical note

In all cases, please observe the instructions and warnings in the owner’s manual of the vehicle.

1.3.2.1 Modifications to the underbody area of the high-voltage battery and the drive

The components for the high-voltage battery system, including the assembly frame, crash elements and powertrain, must not be modified or reworked. No welding or processes that could produce sparks may be used in the underbody area, near the high-voltage components and the high-voltage battery.

The following work must be avoided in the underbody area:

- Work in the direct vicinity of the high-voltage components, high-voltage wires and high-voltage battery using cutting, deforming or sharp-edged tools.
- Fastenings on the vehicle floor that protrude into the area of the high-voltage battery or permanently restrict accessibility to the battery
- Exterior conversions that project into the area of the high-voltage battery or permanently restrict accessibility to the battery.

Warning note

Special safety notes must be observed when working on electric vehicles. Failure to observe safety notes can result in a fatal electric shock.

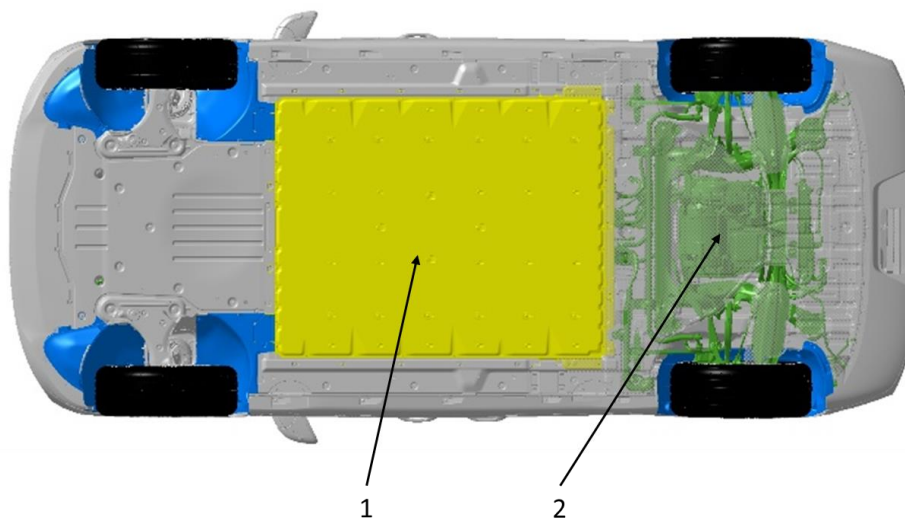

Fig. 1: Underbody of ID Buzz with 82 kWh battery, 150 kW rear-wheel drive

1= 82 kWh high-voltage battery

2= 150 kW rear-wheel drive

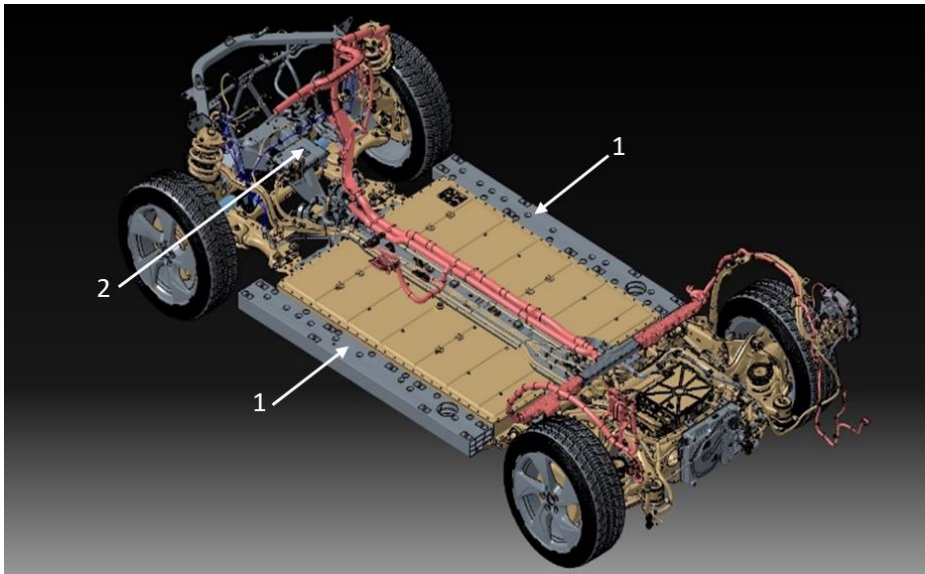

Fig. 2: Vehicle structure with battery (82 kWh) and supply line, and drive unit for 150 kW rear-wheel drive

1= Crash element

2= Power electronics

Warning note

The voltage within the high-voltage vehicle electrics and high-voltage battery is life-threatening!

Touching damaged orange-coloured high-voltage wires and high-voltage battery may result in a fatal electric shock. The high-voltage system may be active even if the ignition is switched off!

- Never carry out any work on the high-voltage vehicle electrics, orange-coloured high-voltage wires, high-voltage components or high-voltage battery. Work on the high-voltage system may only be performed by qualified specialist companies with appropriate accreditation to perform such work.
- Never modify, damage, dismantle or disconnect from the high-voltage system any of the orange-coloured high-voltage wires, high-voltage components or high-voltage battery.
- Work in the vicinity of high-voltage components, high-voltage wires and on the high-voltage battery may not be carried out until after de-energisation. The high-voltage battery cannot be de-energised. The high-voltage disconnection may only be performed by suitably qualified and trained specialist staff.
- If there is a fault in the high-voltage system, the drive is automatically deactivated where necessary, and a corresponding indicator may be displayed in the instrument cluster. Should this be the case, the drive will remain deactivated until the fault has been rectified by suitably qualified and trained specialist staff.
- The various Volkswagen policies must be observed when carrying out any work on the high-voltage vehicle electrics, including in particular on the orange-coloured high-voltage wires, high-voltage components or high-voltage battery.

Information

The required safety notes can be requested. Please contact us (see chapter 1.2.1 “Product and vehicle information for body builders”).

1.3.2.2 Body side panels

Various control units and cables are installed behind the side panels. Please check the required clearance behind the panels before making any changes!

In order to securely attach installations in the cargo area, please use the tie-down rails available with the additional equipment to ensure a secure connection to the body (see also chapter 3.0 “Modifications to closed bodies”).

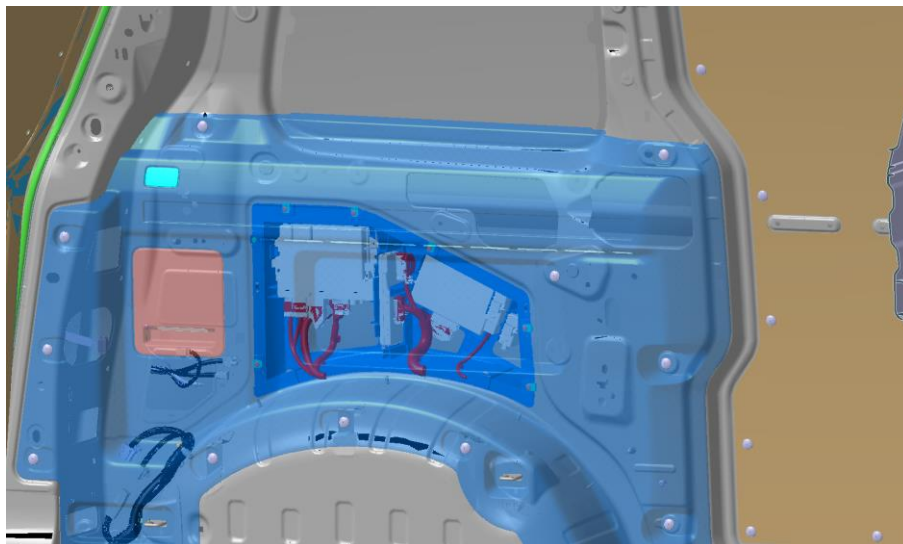

Fig. 1: Rear left side panel with indicated supply lines and control units

1.3.2.3 Electrics

High-voltage battery:

Direct energy consumption at the high-voltage battery is not intended or permitted. Please also note the warnings in this guideline and in the owner's manual of the vehicle.

12 V vehicle electrical system:

(See chapter 2.5 “Electrics”)

1.3.3 Vehicle acceptance

The officially recognised appraiser or tester from the body builder must be informed about modifications to the vehicle.

Practical note

Country-specific laws, directives and approval regulations shall be observed!

1.4 Optional equipment

We recommend using the special equipment from Volkswagen AG that can be obtained with a PR number for optimum adaptation of the body to the vehicle.

You can obtain information on special equipment provided by Volkswagen under PR numbers from your Volkswagen dealership or from your available contacts for product and vehicle information for body builders (see chapters 1.2.1.1 “Contact in Germany” and 1.2.1.2 “International contact”). Please also note chapter 5 “Implementation of special bodies”.

Information

You can also put your vehicle together with the configurator on the Volkswagen AG homepage and look at the available special equipment: <https://www.volkswagen-nutzfahrzeuge.de/de/modelle.html>.

Special equipment (e.g. reinforced springs, frame reinforcements, anti-roll bars etc.) or equipment fitted later increase the kerb weight of the vehicle.

The actual vehicle weight and the axle loads should be determined and documented by weighing before and after the conversion. Not all additional equipment can be installed into every vehicle without problems. This applies in particular if it is fitted later on.

2 Technical data for planning

2.1 Base vehicle

2.1.1 Vehicle dimensions

2.1.1.1. Basic data for ID Buzz Cargo

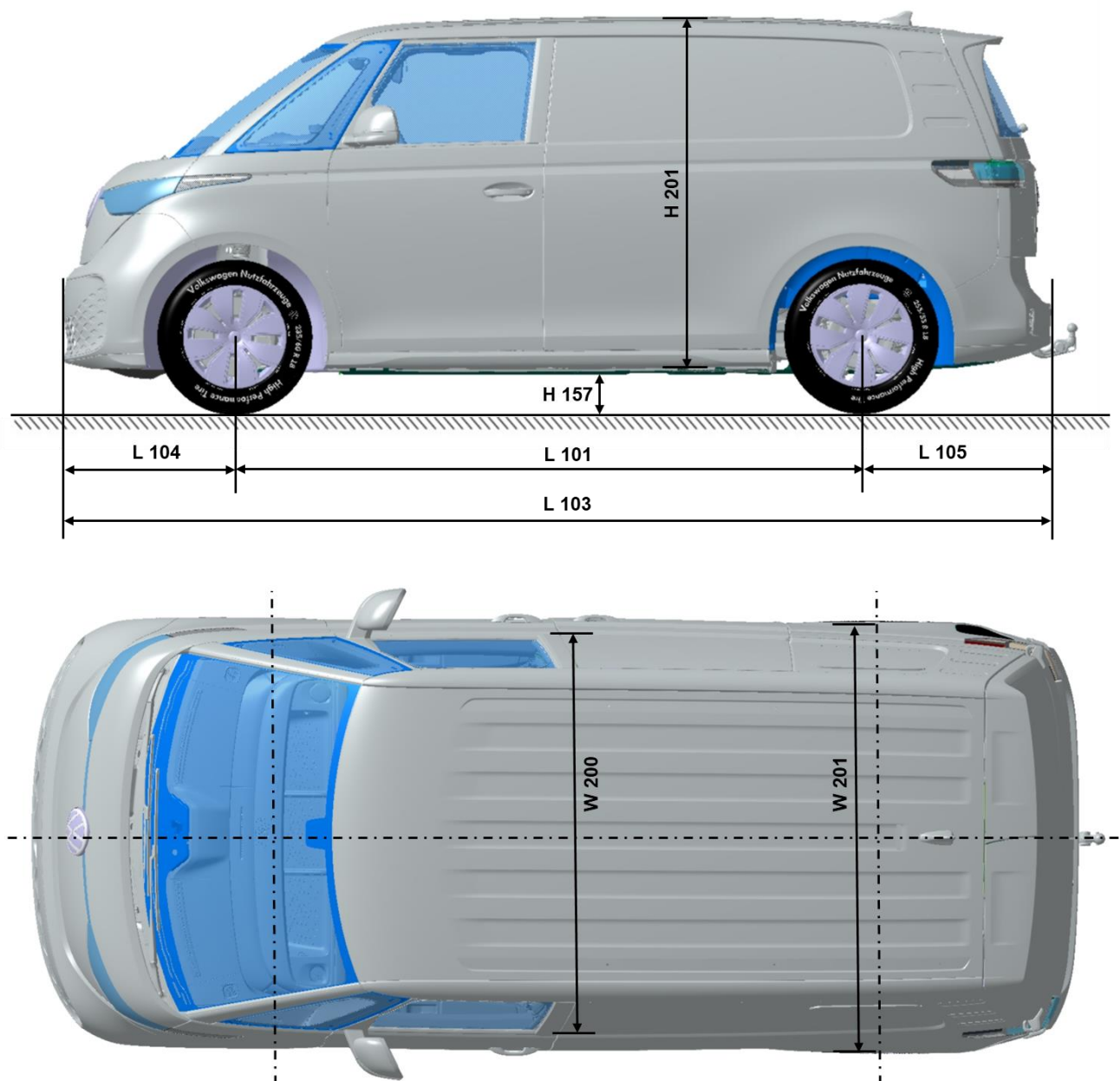

Fig. 1: Example vehicle dimensions of ID Buzz Cargo (acc. to DIN 70020, P1) The dimensions are given in the basic data table below.

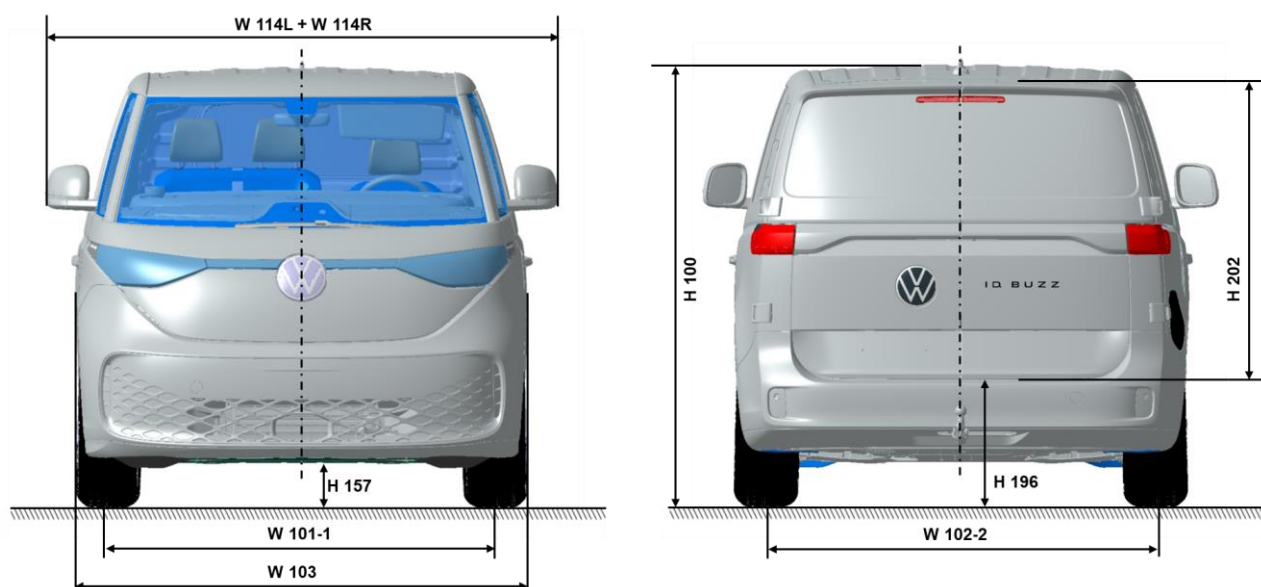

Fig. 2: Example vehicle dimensions of ID Buzz Cargo (acc. to DIN 70020, P1)

Rear view: Figure with wing doors, the ID Buzz Cargo can optionally be ordered with a rear lid. The values (dimensions) can be found in the basic data table.

Basic data for ID Buzz Cargo (ML1*) (All engines)			ID. Buzz [mm]	
Dimensions	L101	Wheelbase (ML1* / ML3**)	2989	
	L103	Vehicle length	4712	
	L102	Vehicle length with rigid towing bracket (removable ball coupling)	4837	
	L515	Centre of gravity position, load compartment, behind the front axle	2679	
	W103	Vehicle width (measuring point: door handle)		1985
	H100	Vehicle height	1895	
		Vehicle height up to navigation aerial	1932	
	L104	Front overhang length	820	
	L105	Rear overhang length	903	
		Rear overhang length with towing bracket	1028	
	W101-1	Track in front: -> with rim offset 45	1673	
	W101-2	Track width at rear: -> with rim offset 56 -> with rim offset 58		1670
				1666
	WX 1	Maximum rear axle width	1954	
WX 2	Maximum front axle width	1933		
H157	Ground clearance between axles acc. to 2007/46/EC	182		
A117	Breakover angle	12.0°		
A116-1	Front overhang angle at full load, limited by spoiler	16.7°		

Basic data for ID Buzz Cargo (ML1*) (All engines)			ID. Buzz [mm]
Dimensions	A116-2	Rear ramp angle at full load, limited by bumper	17.9°
Turning circle	D102	Minimum turning circle (approx.)	
		Left steering wheel (LL) rear-wheel drive	11.09m
		Right steering wheel (RL) rear-wheel drive and LL/RL 4motion	12.54m
Wheels /tyres		Basic tyres, front	235/60 R18 103T
		Basic tyres, rear	255/55 R18 105T
Load compartment measurements L508	L202	Length of the loading platform (EC 1230/2012)	
		With wing door (Y=0)	1999
		With rear lid (Y=0)	1975
	L301-2	Luggage compartment length 1st row of seats	
		(Rear lid Y=0)	2208
		(Wing door Y=0)	2232
	F201-1	Load compartment area	3.2 m ²
	W200	Largest luggage compartment width (measuring point sliding doors)	1732
	W201	Min. load-through width between the wheel housings	1230
	H505	Max. luggage compartment height	1279
	H201	Loading height	1257
		Load height up to cross strut	1218
	H196	Load sill height above ground level	623
	H508	Clear opening height of sliding door	1092
	L508	Clearance opening width of sliding door (without partition)	756
L903	Clear opening width of rear door	608	
H110	Vehicle height with rear lid open		
	-> Mechanical	2192	
	-> Electrically operated rear lid	2206	
H202	Body opening height: with rear lid	1122	
	with wing doors	1122	
W206	Largest width of rear opening	1311	
Garage dimensions	W120-1	Vehicle width, front doors open	3818
	W114-L	Y-coordinate of exterior mirror on driver side	1106
	W114-R	Y-coordinate of exterior mirror on passenger side	1106
	H61-1	Effective headroom – 1st seat row	1032

*ML1 – measurement load, unladen

**ML3 – measurement load, laden

2.1.1.2. Overhang and breakover angle of ID Buzz Cargo

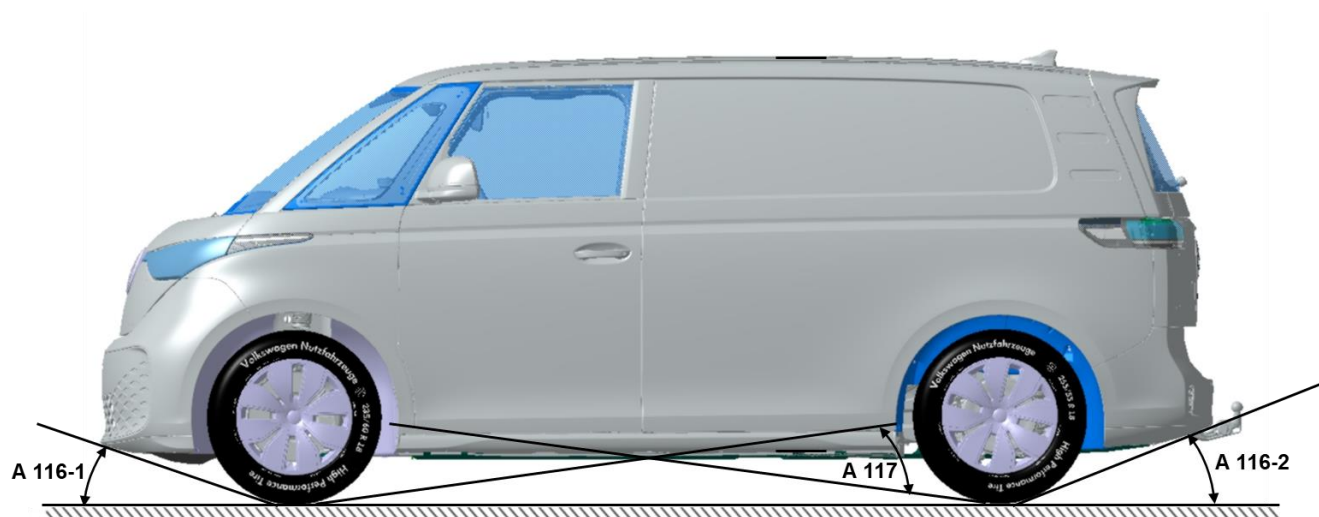

Fig. 1: Example vehicle dimensions of ID Buzz Cargo (acc. to DIN 70020, P1)

The values for the overhang angle (A116) and the breakover angle (A117) can be found in the basic data table (see chapter 2.1.1.1).

2.1.1.3. Basic data for ID Buzz

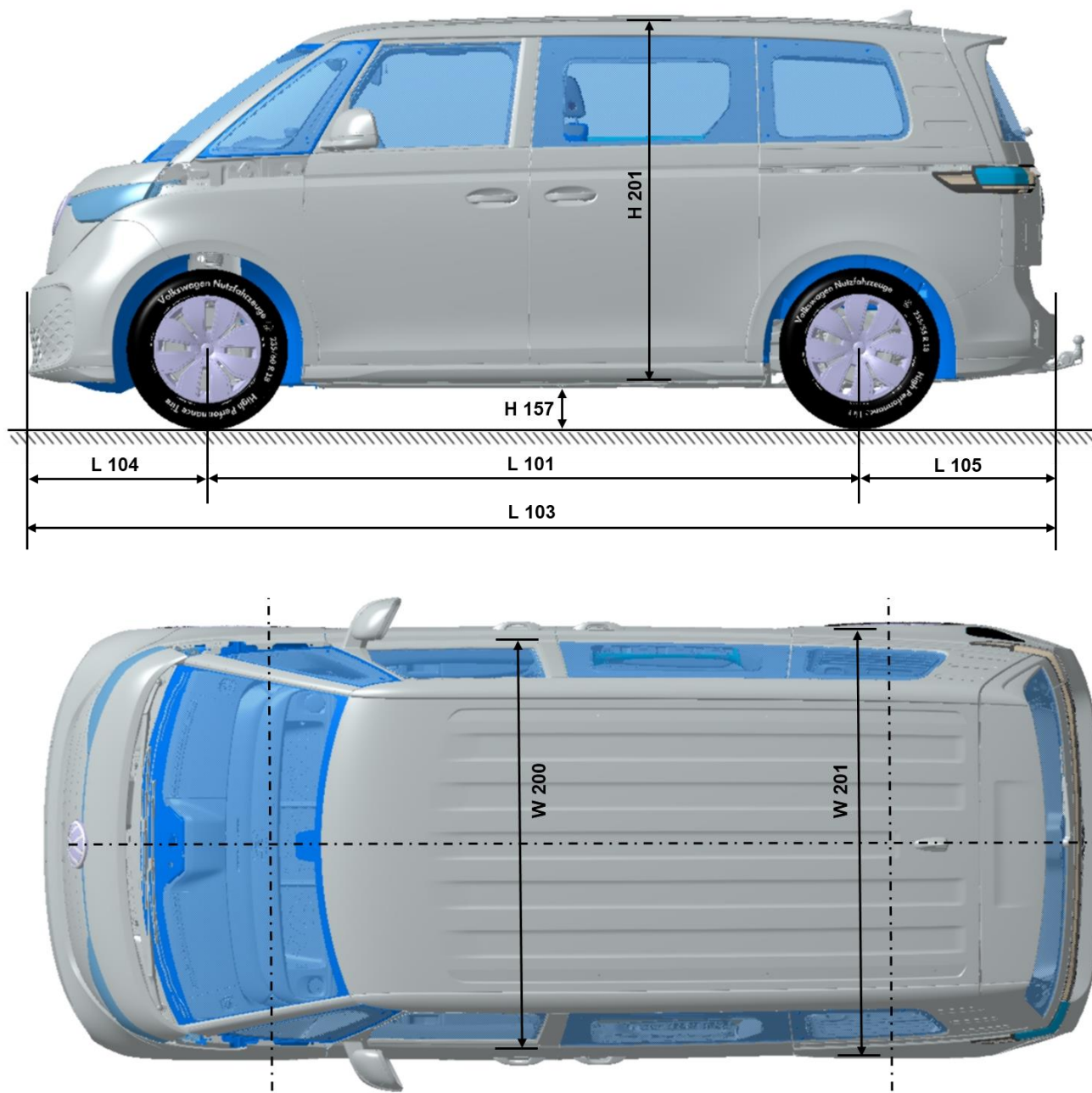

Fig. 1: Example vehicle dimensions of ID Buzz NWB and LWB* (acc. to DIN 70020, P1). The dimensions are given in the basic data table below.

*NWB = normal wheelbase

*LWB = long wheelbase

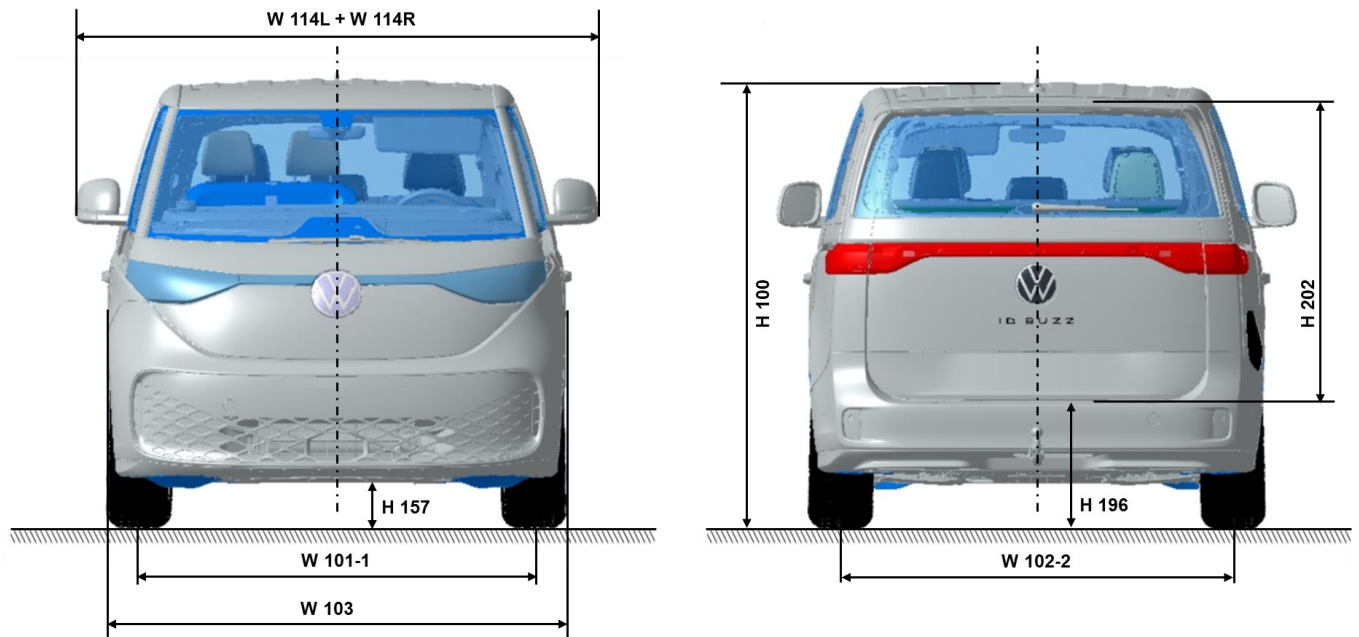

Fig. 2: Example vehicle dimensions of ID Buzz NWB and LWB* (acc. to DIN 70020, P1). The dimensions are given in the basic data table below.

*NWB = normal wheelbase

*LWB = long wheelbase

Basic data for ID Buzz (ML1*) (All engines)			ID Buzz NWB*** [mm]	ID Buzz LWB*** [mm]
Dimensions	L101	Wheelbase (ML1* / ML3**)	2989	3239
	L103	Vehicle length	4712	4962
	L102	Vehicle length with rigid towing bracket (removable ball coupling)	4837	5087
	L515	Centre of gravity position, load compartment, behind the front axle 5-seater 7-seater	3114	3282 3777
	W103	Vehicle width (measuring point: door handle)	1985	1985
	H100	Vehicle height	1891	1891
		Vehicle height up to navigation aerial	1927	1924
	L104	Front overhang length	820	820
	L105	Rear overhang length	903	903
		Rear overhang length with towing bracket	1028	1028
	W101-1	Track at front -> with rim offset 45 -> with rim offset 40	1673	1673
			1683	1683
W102-2	Track at rear -> With offset depth 56 (18") -> With offset depth 58 (21") -> With offset depth 58 (19")	1670	--	
		1667	--	
		--	1666	

Basic data for ID Buzz (ML1*) (All engines)			ID Buzz NWB*** [mm]	ID Buzz LWB*** [mm]
		-> With offset depth 58 (21")	--	1667
	WX 1	Maximum rear axle width	1954	1954
	WX 2	Maximum front axle width	1933	1933
	H157	Ground clearance between axles acc. to 2007/46/EC	179	179
	A116-1	Front overhang angle at full load, limited by spoiler	16.4°	15.9°
	A116-2	Rear ramp angle at full load, limited by bumper	14.8°	15.1°
	A117	Breakover angle	12.0°	11.0°
Turning circle	D102	Minimum turning circle (approx.)		
		Left steering wheel (LL) rear-wheel drive	11.09m	11.79m
		Right steering wheel (RL) rear-wheel drive and LL/RL 4motion	12.54m	13.37m
Wheels/tyres		Basic tyres, front Basic tyres, rear	235/60 R18 103T 255/55 R18 105T	
Load compartment measurements	L202	Length of the loading platform (EC 1230/2012) 5-seater	1105	1270 279
	L212-1	Luggage compartment length, 2nd seat row folded, 3rd seat row removed	2232	2482
		Luggage compartment length, 2nd seat row, 5-seater	1330	1495
	F201-1	Loading area, behind 2nd row of seats	1.69 m ²	1.97 m ²
	W200	Largest luggage compartment width, behind 3rd seat row	1217	1217
	W202	Width between wheel housings	1204	1204
	H212	Height of the luggage compartment, minimum (with cover)	654	654
	H201	Loading height 5-seater	1180	1179
		7-seater		1169
	H196	Load sill height above ground level 5-seater	632	631
		7-seater		636
H508	Clear opening height of sliding door	1162	1162	
L903	Clear opening width of sliding door	757	948	
Load	H101	Maximum vehicle height	1927	1924

Basic data for ID Buzz (ML1*) (All engines)			ID Buzz NWB*** [mm]	ID Buzz LWB*** [mm]
Garage dimensions	H110	Vehicle height with rear lid open -> Mechanical rear lid -> Electrically operated rear lid	2187 2201	2188 2202
	H202	Body opening height 5-seater 7-seater	1096 2201	1096 2202
	W206	Largest width of rear opening	1275	1275
Garage dimensions	W120-1	Vehicle width, front doors open	3818	3818
	W120-2	Vehicle width, rear doors open	2270	2264
	W114-L	Y-coordinate of exterior mirror on driver side	1106	1106
	W114-R	Y-coordinate of exterior mirror on passenger side	1106	1106
Vehicle interior dimensions	H61-1	Effective headroom – 1st seat row Effective head area (with tilting panoramic sunroof (PGD))	1032 1067	1032 1067
	H61-2	Effective headroom – 2nd seat row Effective head area (with tilting panoramic sunroof (PGD))	1044 1075	1042 1074
	H61-3	Effective headroom – 3rd seat row	982	982

*ML1 – measurement load, unladen

**ML3 – measurement load, laden

***NWB = normal wheelbase

***LWB = long wheelbase

2.1.1.4. Overhang and breakover angle of ID Buzz

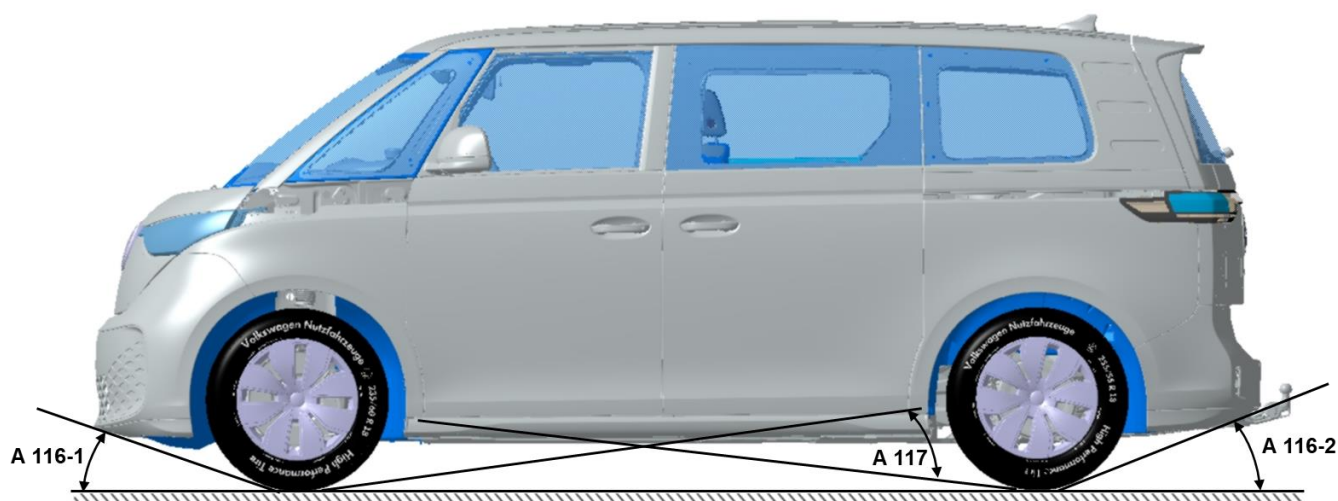

Fig. 3: Example vehicle dimensions of ID Buzz NWB and LWB* (acc. to DIN 70020, P1).

*NWB = normal wheelbase

*LWB = long wheelbase

The values for the overhang angle (A116) and the breakover angle (A117) can be found in the basic data table (see chapter 2.1.1.3).

2.2 Running gear

2.2.1 Permitted weights and unladen weights

Warning note

ATTENTION! Compliance with the maximum gross axle weight ratings specified in these body builder guidelines is required for conversions that lead to an increase in the base vehicle's axle weight rating (e.g. in the case of weight increases). If these values are exceeded, the durability of all components, and in particular the wheel hubs, must be checked and safeguarded using suitable measures!

Information

Equipment features can influence the payload or load weight by increasing/reducing the unladen weight. The weight values stated in the technical data refer to the standard, basic vehicle equipment. Weight tolerances of +5% in production are permitted in accordance with DIN 70020 and must be taken into account if necessary.

Installing special equipment reduces the payload.

The actual payload of a vehicle that is calculated from the difference between the gross vehicle weight rating and unladen weight can only be determined by weighing an individual vehicle.

2.2.1.1 One-sided weight distribution

Warning note

The following weights shall not be exceeded under any circumstances:

- gross vehicle weight rating
- gross front axle weight rating
- gross rear axle weight rating

(see 2.2.1 "Permitted weights and kerb weights").

When planning bodies/additions, make sure that one-sided weight distribution is avoided – in particular involving permanently secured add-ons. If there are different wheel loads, the tyre load capacities must be observed.

2.2.2 Turning circle

See the basic data table (chapter 2.1.1 “Vehicle dimensions”).

2.2.3 Authorised tyre sizes

The Volkswagen owner's manual provides information about the wheel/tyre combinations authorised by Volkswagen AG in conjunction with snow chains (see the table of basic data in chapter 2.1.1 “Vehicle dimensions”).

2.2.4 Modifications to axles

Modifications to the axles are not permitted, because they can lead to an impairment in the driving properties and unstable driving behaviour.

2.2.5 Modifications to the steering system

Modifications to the steering system are not permitted.

Exceptions, e.g. conversions for people with disabilities, shall be approved by Volkswagen AG prior to the conversion.

Please contact us before starting your conversion (see chapter 1.2.1.1 “Contact in Germany”, 1.2.1.2 “International contact”).

2.2.6 Brake system and brake control system

2.2.6.1 General information

Changes to the brake system are not allowed under any circumstances:

- If the modification to the brake system goes beyond the scope of the operating permit.
- If the air inflow and outflow to and from disc brakes are modified.

Warning note

Work performed incorrectly on brake hoses, lines and cables may impair their function.

This can lead to a failure of components or safety-relevant parts. Therefore, work on brake hoses, lines and cables should only be performed by a qualified specialist workshop.

2.2.6.2 Routing additional lines along the brake hoses/brake lines

No other additional lines are allowed to be fastened to brake hoses and brake lines.

Additional lines must remain at a sufficient distance from brake hoses and brake lines under all operating conditions, and are not allowed to touch or chafe against such brake hoses/lines under any circumstances (see chapter 2.5.2.1 “Electrical wiring/fuses”).

2.2.7 Modification of springs, suspension mounting, dampers

The spring rates are never allowed to be modified.

We recommend using optimally matching springs from the Volkswagen delivery range for the vehicle with body.

Modifications to the springs must be appraised and recorded by the applicable technical test centre / monitoring organisation / technical service. Modifications that are not recorded and registered can result in invalidation of the vehicle's operating permit.

Practical note

We indicate that when the vehicle is converted to an air-sprung suspension system due to a change in the vibration behaviour of the wheels, this can lead to possible faulty displays of the factory-installed tyre pressure indicator (TPLI).

Please contact us before any planned modifications to the running gear (see chapter 1.2.1 "Product and vehicle information for body builders").

2.2.8 Wings and wheel housings

The required clearance for the wheels including snow chains must be complied with.

Please take note of the information in the build dimension drawing.

2.3 Body-in-white

2.3.1 Roof loads

2.3.1.1 Dynamic roof loads

Vehicle type	Max. roof load
Vehicles with normal roof and two base carriers	100 kg
Vehicles with normal roof and an additional base carrier	100 kg

See chapter 2.7.1 “Roof carriers” regarding the fitting of roof carriers.

The limit value for the maximum centre of gravity position of the vehicle is not allowed to be exceeded.

2.3.1.2 Static roof loads

The values in the table (see chapter 2.3.1.1 “Dynamic roof loads”) refer to permissible roof loads when the vehicle is moving.

When using a static roof load, the following applies:

A static roof load of up to 250 kg does not cause any damage to the vehicle if the loads are evenly distributed. The maximum roof load may only be used when the vehicle is stationary. Vehicle operation with the static roof load is expressly prohibited. All available connection points of the body for roof carrier systems in the roof area must be used.

Direct loading of the roof surface is not permitted. One-sided loads can cause damage to the roof.

Volkswagen AG offers no warranty for damage to the vehicle resulting from improper use.

2.3.2 Modifications to the body-in-white

Changes to the body are not allowed to impair the function and strength of units and operating devices of the vehicle, neither may they reduce the strength of weight-bearing parts.

During vehicle conversions and installation of bodies, it is not permitted to make any modifications which impair the function and freedom of movement of the suspension (e.g. for maintenance and inspection work) or the accessibility to the same.

2.3.2.1 Screw connections

If series-production bolts / nuts have to be renewed, it is only permitted for bolts / nuts to be used which have the:

- same diameter.
- same strength.
- same bolt standard or bolt type.
- same surface coating (corrosion protection, coefficient of friction).
- same thread pitch.

Comply with VDI guideline 2862 during all installations.

Shortening the free clamping length, changing over to waisted shank and use of bolts with a shorter free thread proportion are not permitted.

Furthermore, take the settling behaviour of screw connections into account.

When attaching components to the base vehicle using screws, made sure that no panels or other components of the base vehicle are bent or damaged.

The use of Volkswagen tightening torques assumes that the total coefficient of friction is in the range $\mu_{tot} = 0.08$ to 0.14 for the particular items being bolted together.

If bolts are tightened by torque and final tightening angle at Volkswagen, no change of design is possible.

Risk of accident

No safety-relevant bolted connections, e.g. for wheel guidance, steering and brake functions, may be modified. Otherwise the designated function may be impaired. This may result in the driver losing control of the vehicle and causing an accident. The new installation is to be carried out according to VW Customer Service instructions, using suitable standard parts. We recommend the use of Volkswagen genuine parts.

Information

Information about Volkswagen customer service instructions can be provided by any Volkswagen Customer Service.

2.3.2.2 Welding work

The following instructions must be observed before carrying out welding work on the body:

- Welding work should only be undertaken by people with appropriate qualifications.
- Before starting welding work, it is necessary to remove components which might contain gases representing a fire or explosion hazard, e.g. fuel system, or else to protect them with a fireproof cover against airborne sparks. Gas containers which could be damaged by airborne sparks during welding work must be removed.
- Welding work should only be undertaken by people with appropriate qualifications.
- Before starting welding work, it is necessary to remove components which might contain gases posing a fire or explosion hazard, or else to protect them with a fireproof cover against airborne sparks.
- Welding, soldering and thermal bonding or the use of hot air in the direct vicinity of the high-voltage components, the high-voltage wires and on the high-voltage battery are not permitted. If a sufficient distance cannot be maintained, the components must be removed. The information in the vehicle-specific Workshop Manual must be observed.
- Work on the high-voltage components may only be performed by qualified personnel.
- Before welding work near seat belts, airbag sensors or the airbag control unit, the components must be removed for the duration of the work.
- Before starting welding work, cover the springs and spring bellows to protect them against weld spatter. Springs are not allowed to be touched with welding electrodes or welding tongs.
- No welding is allowed on units such as the engine and axles.
- The positive and negative battery terminal camps of the 12-V batteries must be disconnected and covered.
- Directly connect the earth clamp of the welding machine to the part to be welded. The earth clamp is not allowed to be connected to mechanical units such as the engine, gearbox, axles.
- The housings of electronic components (e.g. control units) and electrical wiring are not allowed to be touched with the welding electrode or earth clamp of the welding machine.
- The electrodes are only allowed to be used with direct current via the positive terminal for welding. Always weld from bottom towards the top.

Warning note

Incorrectly undertaken welding work can lead to a failure of safety-relevant components, and thus cause accidents.

Warning note

Welding in the area of the restraint systems (airbag or belts) can lead to these systems ceasing to function properly.

Welding in the area of child restraint systems is therefore prohibited.

Practical note

Disconnect the battery prior to starting welding work. Airbags, seatbelts, the airbag control unit and airbag sensors shall be protected against weld spatter, and removed if necessary.

Warning note

Special safety notes must be observed when working on electric vehicles. Failure to observe safety notes can result in a fatal electric shock.

Warning note

The voltage within the high-voltage vehicle electrics and high-voltage battery is life-threatening!

Touching damaged orange-coloured high-voltage wires and high-voltage battery may result in a fatal electric shock. The high-voltage system may be active even if the ignition is switched off!

- Never carry out any work on the high-voltage vehicle electrics, orange-coloured high-voltage wires, high-voltage components or high-voltage battery. Work on the high-voltage system may only be performed by qualified specialist companies with appropriate accreditation to perform such work.
- Never modify, damage, dismantle or disconnect from the high-voltage system any of the orange-coloured high-voltage wires, high-voltage components or high-voltage battery.
- Work in the vicinity of high-voltage components, high-voltage wires and on the high-voltage battery may not be carried out until after de-energisation. The high-voltage battery cannot be de-energised. The high-voltage disconnection may only be performed by suitably qualified and trained specialist staff.
- If there is a fault in the high-voltage system, the drive is automatically deactivated where necessary, and a corresponding indicator may be displayed in the instrument cluster. Should this be the case, the drive will remain deactivated until the fault has been rectified by suitably qualified and trained specialist staff.
- The various Volkswagen policies must be observed when carrying out any work on the high-voltage vehicle electrics, including in particular on the orange-coloured high-voltage wires, high-voltage components or high-voltage battery.

Information

The required safety notes can be requested. Please contact us (see chapter 1.2.1 “Product and vehicle information for body builders”).

2.3.2.3 Welded connections

In order to achieve high-quality welds, the following basic recommendations are given:

- Thoroughly clean the areas to be welded.
- Apply several short weld beads, rather than one long one.
- Make symmetrical beads, in order to limit shrinkage.
- Avoid making more than three welds at any one point.
- Avoid welding in work-hardened areas.
- Spot welds and stitch welding should be offset.

2.3.2.4 Selection of welding process

The mechanical properties of welds depend on which welding process is selected, and on the geometry of the parts to be connected.

If welding overlapping metal panels, the welding process depends on the accessibility of the sides:

Accessible sides	Welding process
1	Shielding gas hole spot welding
2	Spot welding

2.3.2.5 Spot welding

Spot welding is used for overlapping parts with access on both sides. Avoid spot welding of more than two layers of metal panels.

Distance between spot welds:

In order to avoid shunt effects, the specified distances between the spot welds must be maintained ($d = 10e + 10 \text{ mm}$).

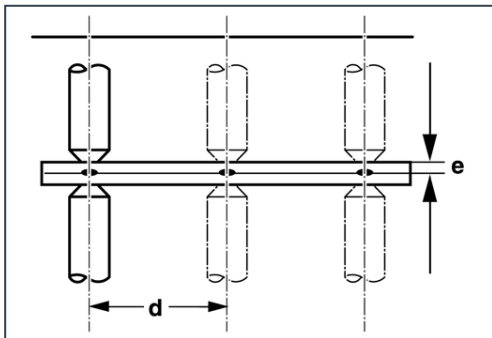

Ratio between panel thickness and distance between welds

d Distance between spot welds

e Panel thickness

Distance from the edge of the panel:

In order to avoid damage to the molten core, the specified distances from the edge of the panel must be maintained ($L = 3e + 2 \text{ mm}$).

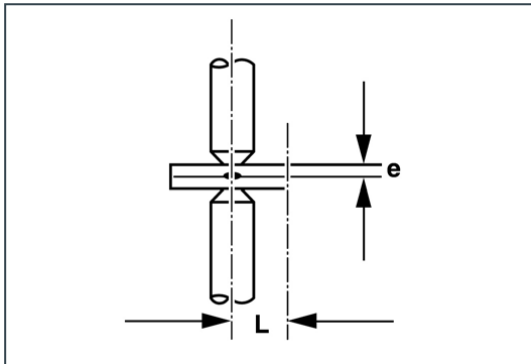

Ratio between panel thickness and distance from edge

e Panel thickness

L Distance from the edge of the panel

2.3.2.6 Shielding gas hole spot welding

If overlapping panels can only be welded on one side, it is possible to achieve the connection by protective gas hole spot welding or tacking. If the connection is achieved by punching or drilling and then hole spot welding, the drilling area must be deburred before welding.

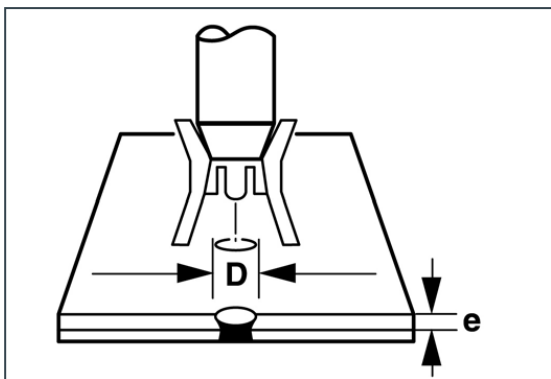

Ratio between panel thickness and hole diameter

D – hole diameter [mm]	4.5	5	5.5	6	6.5	7
e – panel thickness [mm]	0.6	0.7	1	1.25	1.5	2

The mechanical quality can additionally be improved by using slots ($l = 2 \times b$).

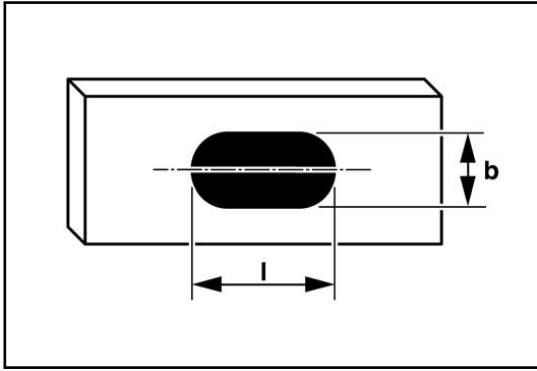

Ratio between width and length of slots

b Width of slot

l Length of slot

2.3.2.7 Tacking

If panels are >2 mm thick, overlapping panels can also be connected by tacking ($30 \text{ mm} < L < 40 \times e$; $d > 2 L$).

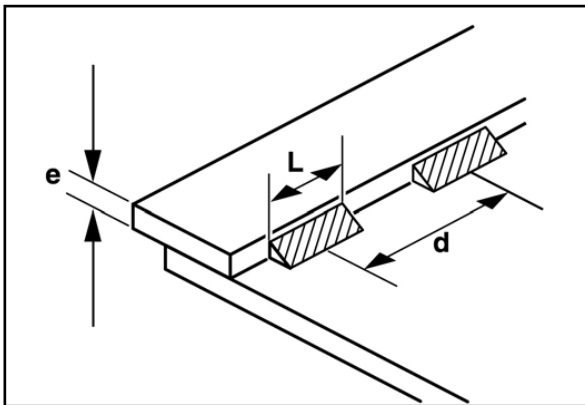

Ratio between panel thickness and distance between welds

d Distance between tack welds

e Panel thickness

L Length of tack weld

2.3.2.8 Welding is not allowed

Welding is not allowed:

- On mechanical units such as the engine, gearbox, axles etc.
- On the chassis frame except if there is a frame extension.
- On the A and B-pillars.
- On the upper and lower chords of the frame.
- In bend radii.
- In the area of airbags.
- Hole welding is only permitted in the vertical webs of the frame longitudinal member.

2.3.2.9 Corrosion protection after welding

After all welding work on the vehicle, it is necessary to comply with the specified corrosion protection measures (See chapter 2.3.2.10 “Corrosion protection measures”.)

2.3.2.10 Corrosion protection measures

Following conversion and installation work on the vehicle, surface and corrosion protection shall be applied to the affected points.

Practical note

Only the corrosion protection agents tested and approved by Volkswagen are allowed to be used for all corrosion protection measures.

2.3.2.11 Planning measures

Corrosion protection should be taken into account in the planning and design in the form of a suitable material selection and component design.

Information

If two different metallic materials are connected together by an electrolyte (e.g. moisture from the air) then this will give rise to a galvanic connection. The result will be electrochemical corrosion, and the less noble metal will suffer damage. The electrochemical corrosion will be all the greater the further apart the metals in question are in the electrochemical series.

Therefore, the components must have a suitable treatment or insulation applied to them in order to prevent electrochemical corrosion, or the corrosion must be kept at a low level by a suitable choice of materials.

Avoidance of contact corrosion by electrical insulation

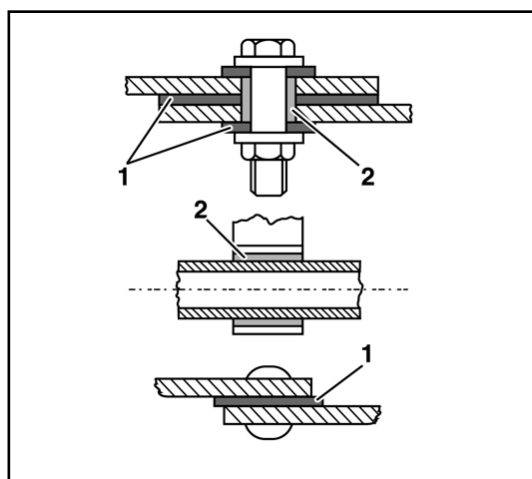

Avoidance of contact corrosion (example)

1 Insulating washer

2 Insulating sleeve

Contact corrosion can be avoided by using electrical insulation such as washers, sleeves or tubes. Avoid welding work on inaccessible cavities.

2.3.2.12 Component design measures

Design measures, in particular in the design of connections between the same or different materials, can be used for providing corrosion protection:

Corners, edges, beads and folds represent locations where dirt and moisture can collect.

Suitable surfaces, drains and the avoidance of gaps at component connections represent means by which corrosion can be counteracted by design measures.

Gaps at welded connections as a feature of the design, and how to avoid them

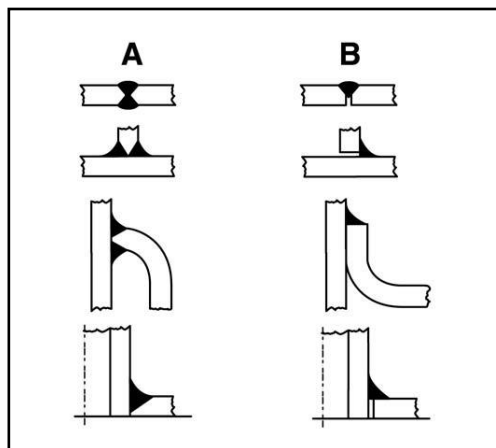

Variants of welded joints (example)

A = Favourable	B = Unfavourable
(through-welded)	(gap)

2.3.2.13 Coating measures

It is possible to protect the vehicle against corrosion by applying protective coatings (e.g. galvanizing, painting or high-temperature zinc application)

(See chapter 2.3.2.10 "Corrosion protection measures").

2.3.2.14 Work on the vehicle

After all work on the vehicle:

- Remove drilling chips.
- Deburr edges.
- Remove scorched paint and thoroughly prepare the surfaces for painting.
- Apply a primer to all bare metal parts, and paint them.
- Apply a wax-based corrosion protection agent to cavities.
- Carry out corrosion protection measures on the underbody and frame components.

2.4 Interior

2.4.1 Modifications in the area of airbags

Modifications on the airbag system and the belt tensioner system as well as on and in the area of airbag components, the airbag sensors and the airbag control unit are not permitted.

The interior fittings shall be designed so that the airbag deployment areas are left unobstructed (see also chapter 3.1 "Interior").

For information about the deployment zones of the airbags, refer to the owner's manual of the vehicle.

Warning note

Modifications or incorrectly performed work on seatbelts and seatbelt anchor points, belt tensioners or airbags or their cabling could impair the correct function of these components. They might be activated inadvertently or fail in the event of an accident.

2.4.2 Modifications in the area of seats

The strength data for seats available ex-works is only valid in conjunction with the original attachment system.

Warning note

Only fit seat covers or protective covers that are expressly approved for use in the vehicle.

The use of non-approved covers may prevent the side airbag from deploying.

Practical note

Modifications to the original series production condition can result in the withdrawal of type approval.

Country-specific laws, directives and approval regulations must be observed!

2.4.2.1 Belt anchors

The body builder is solely responsible for fitting additional belt points.

The necessary proof is to be provided by the body builder.

The country-specific laws, directives and approval regulations must be observed!

2.4.3 Forced ventilation

Replacement measures must be created for vehicle modifications of any kind that can influence the standard forced ventilation. The installed alternative vents must correspond to the factory-mounted forced ventilation cross-sections.

This is important in several respects:

- Closing comfort of the doors
- Possible flow rate of the heating blower
- Pressure equalisation on airbag deployment

Air inlets and outlets are not allowed to be fitted in the immediate vicinity of sources of noise or exhaust gases.

2.4.4 Acoustic insulation

During conversions, make sure that the noise level of interior noise is not changed. Noise insulating materials can be installed to reduce the noise level in the vehicle interior. This must be manufactured from flame-retardant materials.

2.4.5 eCall Emergency System

In the event of an accident, the EU eCall Emergency System can help to reduce the time it takes until emergency services arrive at the scene. Data is transmitted to the emergency response coordination centre via the OCU communication model.

The emergency call therefore does not depend on a mobile telephone being ready for operation, but does require a mobile phone connection and the possibility of locating the vehicle via GPS or Galileo. It is triggered automatically by the crash sensors or manually by the driver using the SOS button. The emergency call automatically goes to the nearest emergency response coordination centre.

General conditions:

The ecall Emergency System consists of the following components:

- Communication module (OCU)
- Emergency call button
- Microphone
- Additional loudspeaker for telematics
- Aerials for mobile network
- Global satellite navigation system
- and their connections and cables.

As this is a certified system, no changes to components of the ecall Emergency System are permitted.

It should also be ensured in particular that the acoustic properties of the eCall Emergency System (emergency call loudspeakers and microphone) are not changed by constructional changes to the vehicle.

2.5 Electrics/electronics

Incorrect interventions in electronic components and their software may result in these no longer functioning as intended. Due to the networking of electronics, systems that were not modified can be affected. Malfunctions to the electronics can significantly impair the operational safety of your vehicle.

Work on or modifications to electronic components, in particular work on safety-relevant systems, is only allowed to be performed by a qualified specialist workshop, and by qualified specialist personnel who have the necessary specialist knowledge and tools for performing the necessary work.

Interventions in the vehicle electrical system/vehicle electronics can result in invalidation of the warranty/operating permit.

If modifications are made to the electrical system, take the vehicle to a VW workshop in order to delete the entries in the event memory at the completion of work. If a VAS tester is available, the event memory can also be deleted by trained personnel of the body builder.

2.5.1 Lighting

2.5.1.1 Vehicle lighting devices

Comply with the country-specific registration provisions with regard to the complete lighting devices (lighting and turn indicator devices). Failing to comply can result in the operating permit being invalidated.

All of the exterior lighting uses LED technology. Fitting other lights instead of genuine VW lights can result in the bulb failure monitor being triggered, because the lighting system is a self-contained and harmonised system.

The bulb failure monitor cannot be deactivated.

We recommend using Volkswagen Genuine lights or a product using LED technology.

Please note that in the completed (converted) vehicle, it is necessary to comply with the add-on regulations and dimensions of all technical lighting equipment acc. to UNECE Regulation UNECE-R 48.

2.5.1.2 Adjusting the headlights

The country-specific registration provisions apply.

The basic setting for the headlights must be put into effect and must be included in the configuration of the new construction status (e.g. fixed installations or add-on parts or changes to running gear components) of the vehicle.

It must be ensured that the adjustment range of the headlight range control complies with potential load levels.

Information

More information about headlight settings can be found in the Volkswagen AG Workshop Manuals/Maintenance Manual on the Internet:
<http://erwin.volkswagen.de/erwin/showHome.do>

*Information system from Volkswagen AG, subject to payment

2.5.2 Vehicle electrical system

Please note:

For bodies and conversions with electromagnetic switching mechanisms (such as relays, magnetic switches, contactors and solenoid valves), these components must be equipped with integrated protective diodes (free-wheel diodes/anti-surge diodes), in order to exclude interference voltage peaks from the vehicle electrical system and the control units. If no protective diodes are integrated, these must be retrofitted antiparallel to the switch coil.

Information

Please refer to “Additional technical information”* in the conversion portal for more information on protecting the control units integrated in the vehicle electrical system from interference voltage peaks of electromagnetic add-ons and conversions.

Please contact us (see chapter 1.2.1 “Product and vehicle information for body builders”).

*Registration required.

2.5.2.1 Electrical wiring / fuses / in reference to the 12 V electrical system

The following points shall be complied with if routing modifications are required:

- Avoid routing over sharp edges.
- Avoid routing inside excessively narrow cavities and close to moving parts.
- No additional lines are allowed to be fastened to brake hoses and brake lines.
- Additional lines must remain at a sufficient distance from brake hoses and brake lines under all operating conditions, and are not allowed to touch or chafe against such brake hoses/lines under any circumstances.
- Only lead-free PVC jacketed cables with an insulation limit temperature >105°C must be used.
- Connections must be made professionally and must be water-tight.
- The cable shall be dimensioned according to the current drawn and protected by fuses.

Max. continuous current [A]	Rated current of fuse [A]	Wire cross-section [mm ²]
0 – 4	5*	0.35
4.1 – 8	10*	0.5
8.1 – 12	15*	1
12.1 – 16	20*	1.5
16.1 – 24	30*	2.5
24.1 – 32	40**	4
32.1 – 40	50**	6
40.1 – 80	100	10
80.1 – 100	125	16
100.1 – 140	175	25
140.1 – 180	225	35
180.1 – 240	300	50

* Shape C; DIN 72581 blade-type connector

** Shape E; DIN 72581 blade-type connector

Warning note

No additional electrical cables or other lines are allowed to be secured to existing lines such as brake or fuel lines or cables, because standard holders might otherwise be overloaded. An independent attachment solution must be found.

2.5.2.2 Additional circuits

Additional circuits (in reference to the 12 V electrical system) must be protected against the main circuit by suitable fuses.

All cables must be dimensioned according to the load, and protected against pulling off and the effects of impacts and heat.

When unprotected cables are routed in the area of the battery, these cables must be protected with special anti-cut hoses in accordance with series production (e.g. Aramid hose/Kevlar).

Information about sources for obtaining anti-cut hoses can be provided if required.

Please contact us in this regard (see chapter 1.2.1 "Product and vehicle information for body builders").

For bodies and conversions with electromagnetic switching mechanisms (such as relays, magnetic switches, contactors and solenoid valves), these components must be equipped with integrated protective diodes (free-wheel diodes/anti-surge diodes), in order to exclude interference voltage peaks from the vehicle electrical system and the control units. If no protective diodes are integrated, these must be retrofitted antiparallel to the switch coil.

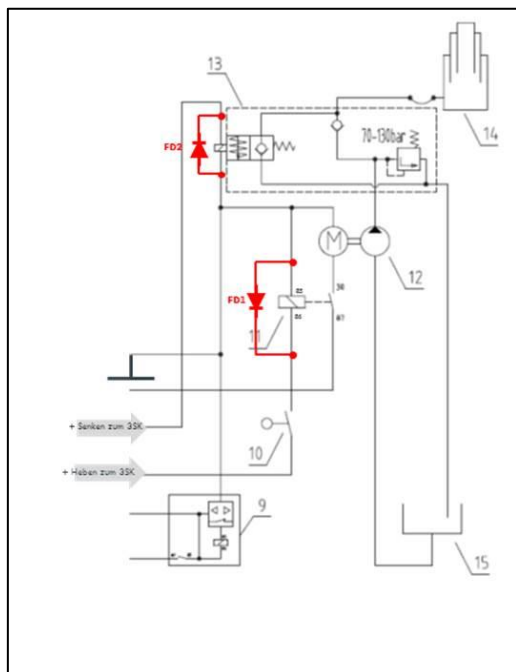

Fig. 1: Tipping control circuit

11-Electro-hydraulic tipping valve

12-Hydraulic pump with motor

13-Motor relay (lifting tipper bed)

FD1-Free-wheeling diode for motor relay

FD2-Free-wheeling diode for tipping valve

Practical note

For subsequent superstructures and modifications for vehicles, it is essential to make sure there are no voltage spikes $>150\text{ V}$ in the vehicle electrical system. For conversions, suitable measures must be taken to ensure this (e.g. by using protection diodes).

Information

Please refer to “Additional technical information”* in the conversion portal for more information on protecting the control units integrated in the vehicle electrical system from interference voltage peaks of electromagnetic additions and conversions.

Please contact us (see chapter 1.2.1 “Product and vehicle information for body builders”).

2.5.2.3 Fuse carrier with emergency cut-out connection

Fig. 1: Position of the fuse carrier in the rear left of the load compartment, behind the trim

Practical note

In the event of modifications and superstructures in the load compartment, ensure that access is guaranteed to the fuse carrier and the emergency cut-out connection (identifiable by the yellow flag). Please refer to your vehicle’s owner’s manual for information on the assignment of the fuse slots.

2.5.2.4 Electromagnetic compatibility

Electromagnetic compatibility (EMC) is defined as the property of an electrical system enabling it to behave neutrally with full functionality in the

vicinity of other systems. Active systems in the surrounding area are not disrupted by the system, nor is system itself impaired.

Electrical interference in motor vehicle electrical systems is caused by the individual electrical loads. At Volkswagen AG, the factory-fitted electronic components have been checked for their electromagnetic compatibility in the vehicle.

When electrical or electronic systems are retrofitted, it is also necessary to check and demonstrate their electromagnetic compatibility.

The devices shall possess a type approval in accordance with UNECE-R 10 and shall bear the “e” mark.

Volkswagen does not issue a manufacturer’s declaration for electromagnetic compatibility when additional devices are subsequently installed by body builders.

Should you have any questions, please contact Volkswagen AG. Please refer to chapter 1.2.1 “Product and vehicle information for body builders”.

2.5.2.5 Mobile communication systems

1. Mobile phones

Commercially available mobile phones may be operated in the vehicle interior. Observe the respective national regulations for the transmission powers during use. Information about the radio bands can be found in the current vehicle-related manufacturer's declaration.

An installation set with external aerial is recommended for an optimum transmission and reception quality and to connect to wireless networks outside of the vehicle. The appropriate interface is available for the mobile phone ex-works as special equipment.

2. Mobile phones for authorities and organisations with security tasks

Two-way radios complying with the technical directives of authorities and organisations with security tasks may be installed and operated in the vehicle with the appropriate installation set (according to the vehicle-specific manufacturer’s declaration).

Information

Additional information about the operation of mobile two-way radios is available in the “vehicle-specific manufacturer’s declaration” for the ID Buzz.

It is filed in the body builder portal of Volkswagen AG under the heading: “Additional technical information”*.

*Registration required.

2.5.2.6 CAN bus

Warning note

Interventions in the CAN bus and connected components are unauthorised.

The CAN BUS must not be modified due to the networking and internal monitoring of electrical equipment (e.g. by interrupting, extending or “tapping”, and reading and writing). Any modification to the wiring harness in terms of length, cross-section or resistance could cause failure of safety-relevant components or result in a loss of comfort.

Internal and external vehicle diagnosis is possible via the OBD diagnostic connection (SAE 1962). Each control unit is self-diagnosis capable and has a fault memory.

Communication with the control unit can be carried out using ODIS (Offboard Diagnostic Information System) and the software that has been developed for this purpose.

Practical note

The body builder can use the external CAN bus interfaces on the CFCU to exchange predefined data with the data bus system of the base vehicle (CIA 447 or J1939).

Outside of these interfaces and predefined data strings, no data may be exchanged with the internal data bus of the base vehicle. Furthermore, no online interfaces may be connected to the above CAN BUS interfaces (an online interface is an interface that can potentially be connected to the Internet, such as *Wi-Fi, Bluetooth, *NFC, *NAD, etc.).

In case of non-compliance, the body builder is required to have a new system test performed according to UN ECE R 155.

To prevent outside intervention in the vehicle control system, the vehicle manufacturers (OEM) are constantly implementing the UNECE regulations on cyber security (CS) and software update management system (SUMS).

If vehicles are modified or supplemented by body builders following delivery by the vehicle manufacturer, the specifications from the UNECE regulations must be observed and implemented.

* WLAN = wireless local area network

*NFC= near field communication (contactless data transmission using radio frequency identification (RFID) technology),

*NAD= network access device (telephone module)

Information

Your Volkswagen customer service department can provide you with further information.

2.5.3 Electrical interface for special vehicles

2.5.3.1 General notes on the interface for special vehicles

Basic requirements for using the interface:

- These interfaces are only allowed to be used by authorised specialist personnel.
- Inappropriate interventions can result in damage to the vehicle and breakdowns, and may also invalidate the operating permit.
- The parameters of the special vehicle control unit are only allowed to be set in consultation with Volkswagen.
- Connections must be made properly (see section 2.5.2.1 “Electrical wiring/fuses”).
Subject to technical modifications.

The following points must be observed at all times:

- VDE guidelines for configuration and fitting of electrical wiring and components (cable cross sections, fuses etc.)
- Only components approved by Volkswagen are allowed to be used for adapting to the vehicle electrical system.
When using additional electrical equipment, the body builder must ensure a balanced current supply.
- EMC safety for connections after the interface is the responsibility of the company fitting out the vehicle.
- The cable cross sections of the interfaces will be maintained throughout the entire circuit, i.e. no cross-section reductions are permitted after the interface.
- Energy must only be supplied to the vehicle electrical system at potentials expressly provided for this purpose and will be fused externally in accordance with VDE guidelines.
- All electrical wiring connected to the vehicle electrical system shall be reliably and durably protected against overload to battery “+”.
- Earth potential: The specified potentials always refer to the vehicle body earth.

Information

Volkswagen AG workshop manuals and circuit diagrams can be downloaded from the Internet at **erWin*** (Electronic Repair and Workshop Information from Volkswagen AG):
<http://erwin.volkswagen.de/erwin/showHome.do>

*Information system from Volkswagen AG, subject to payment

2.5.3.2 Electrical interface for special vehicles / electrical terminal strip IS1*

Additional electrical consumers must be connected using the terminal strip for auxiliary consumers (PR number IS1) that is available ex works. The terminal strip incl. mating connector is fitted under the left front seat and has eight connections. (4x potential terminal 30 and 4x potential terminal 15).

(* Expected to be available from the third quarter of 2024)

Terminal 30 (at pins 1, 3, 5 and 7)	12 V/max. 30 A total current
Terminal 15 (at pins 2, 4, 6 and 8)	12 V/max. 3 A total current

Table with PIN assignment

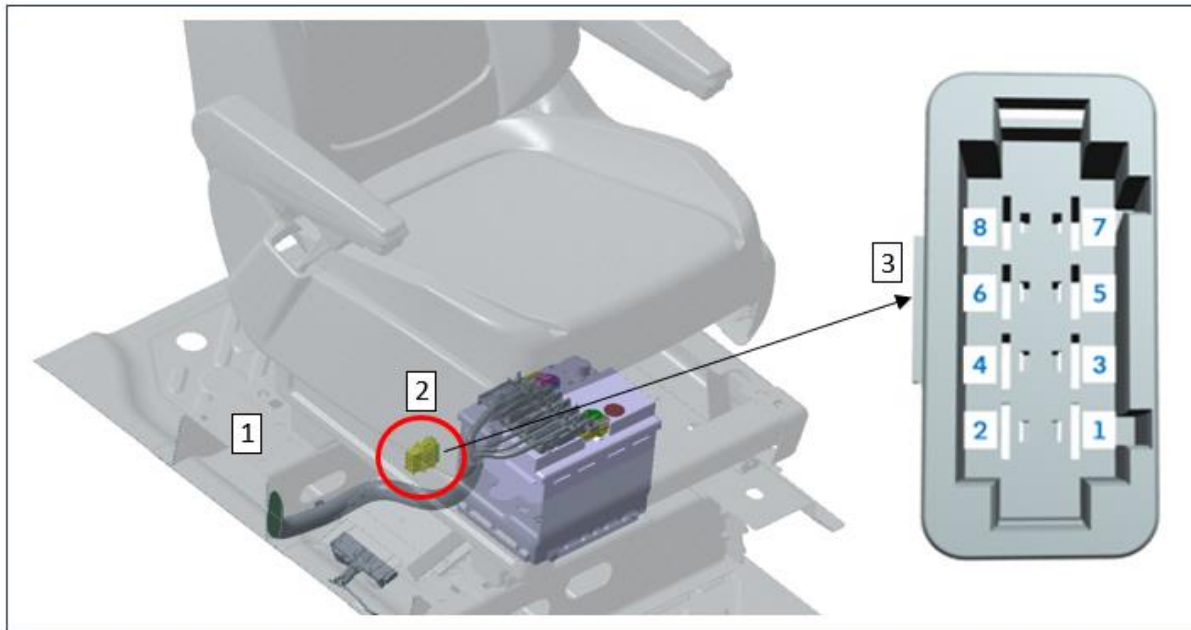

Fig. 1: Left front seat with position of the vehicle electrical system battery and terminal strip in the lower seat pan frame.

1 Lower seat pan frame

2 Position of the terminal strip

3 View of the terminal strip with the PIN assignment

Information

To prevent damage to the contacts or contamination, the vehicle is delivered with a mating connector, part number 1J0.972.774, which is plugged onto the terminal strip.

2.5.4 Vehicle battery – 12-V vehicle electrical system battery

The 12 V battery is installed under the driver seat as standard.

PR no.	Battery type	Battery capacity
J0H	AGM battery (absorbent glass mat battery)	58 Ah / 380A

If a vehicle is not operated for a long time, its battery gradually discharges due to the electrical loads (clock, tachograph, 12 volt socket) and can suffer permanent damage.

To prevent this damage, check the battery open-circuit voltage in accordance with the maintenance cycle and charge the battery (see chapter 1.2.6 “Recommendations for vehicle storage”).

2.5.4.1 230 V inverter

The 230 V inverter (PR no. 9Z3, 9Z6) is installed under the front passenger seat of the ID Buzz.

The inverter is designed for continuous maximum operation at 300 W and for short periods of operation at 450 W. It is automatically activated when readiness to drive is established and a connector is connected. If the vehicle goes into standby mode, the inverter will still be supplied with power for up to 10 minutes if there is enough energy available in the 12 V onboard supply. If the connector is disconnected again during this time, the inverter automatically disconnects from the power supply and can only be used again once readiness to drive has been established.

2.5.5 Driver assist systems

Warning note

Improper interventions in, or installations in, vehicle systems, safety-relevant components or driver assist systems can impair their function. This can result in failure or malfunctions of components or safety-relevant components. Accidents or damage to the vehicle may occur as a result.

Practical note

In vehicles with assist systems (such as the Lane Assist), conversions may cause falsification of the calibration. Flawless function of the multifunction camera and the ACC* would not be ensured. Once a body has been built or conversion made, a calibration of the driver assist systems installed must therefore be carried out by an authorised specialist workshop.

Information

You will find further information on the installation and removal of assist systems, such as ACC* and the multifunction camera, on the **erWin**** web page (Electronic Repair and Workshop Information from Volkswagen AG):
<http://erwin.volkswagen.de/erwin/showHome.do>

*AdaptiveCruiseControl

**Information system from Volkswagen AG, subject to payment

2.5.6 Earth points

Use the earth points provided by Volkswagen for subsequent electrical add-ons or installations to ensure an optimum earth connection to the base vehicle.

Warning note

The use of other earth points can lead to malfunctions in safety systems. This can lead to a failure of components or safety-relevant parts and to error messages in the instrument cluster.

A maximum of 4 terminals are allowed to be screwed to an earth point.
The earth points of the safety systems are not allowed to be used for bodies.

Information

A general overview and more detailed information on earth points can be found in the up-to-date current flow diagram on the **erWin*** web page (**E**lectronic **R**epair and **W**orkshop **I**nformation from Volkswagen AG):
<http://erwin.volkswagen.de/erwin/showHome.do>

*Information system from Volkswagen AG, subject to payment

In the case of further requirements, please contact us (see chapter 1.2.1 "Product and vehicle information for body builders".)

2.6 Battery and drive for electric vehicle

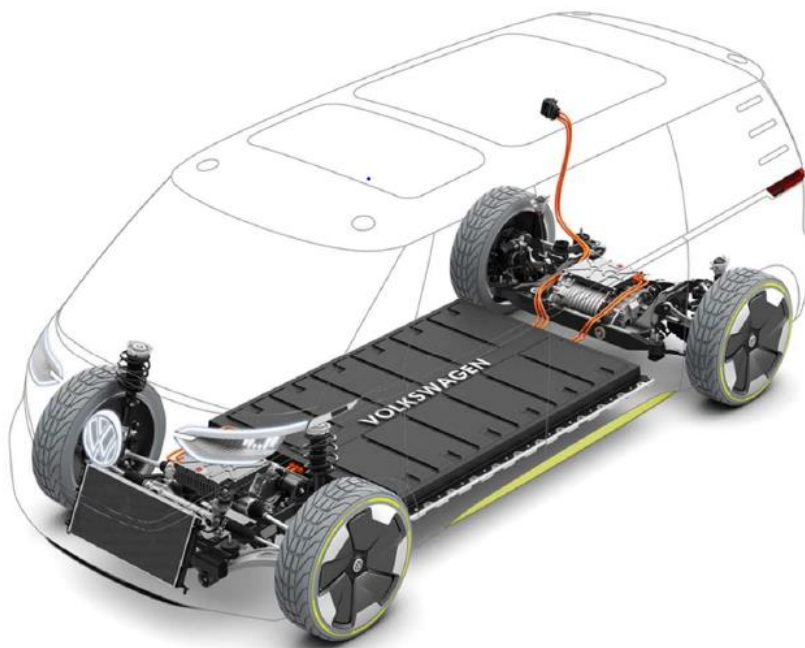

Technical data

Gross capacity of high-voltage battery [kWh]:	82 / (84* / 91*)
Drive:	rear wheels/all-wheel drive**

*Expected from second quarter of 2024

**Expected from third quarter of 2024

Practical note

Modifications to the electric drive system are not permitted. Solutions regarding engine speed control are not possible. Modifications to the cooling system (radiator, air intake, air ducts etc.) are not permitted. Cooling air inlet surfaces must be kept clear.

Warning note

Changes to the electrical drive system can lead to the system ceasing to function properly. Control of the vehicle may be lost.

2.6.1 High-voltage system

The high-voltage system consists of the following components:

- High-voltage battery
- Power electronics
- Electric motor
- High-voltage air conditioner compressor
- High-voltage battery charging unit
- High-voltage battery charging socket
- Orange-coloured high-voltage wires and connectors
- High-voltage heater

All work carried out on the high-voltage system must be performed exclusively by a suitably qualified specialist company deploying suitably qualified and trained staff in accordance with Volkswagen's policies.

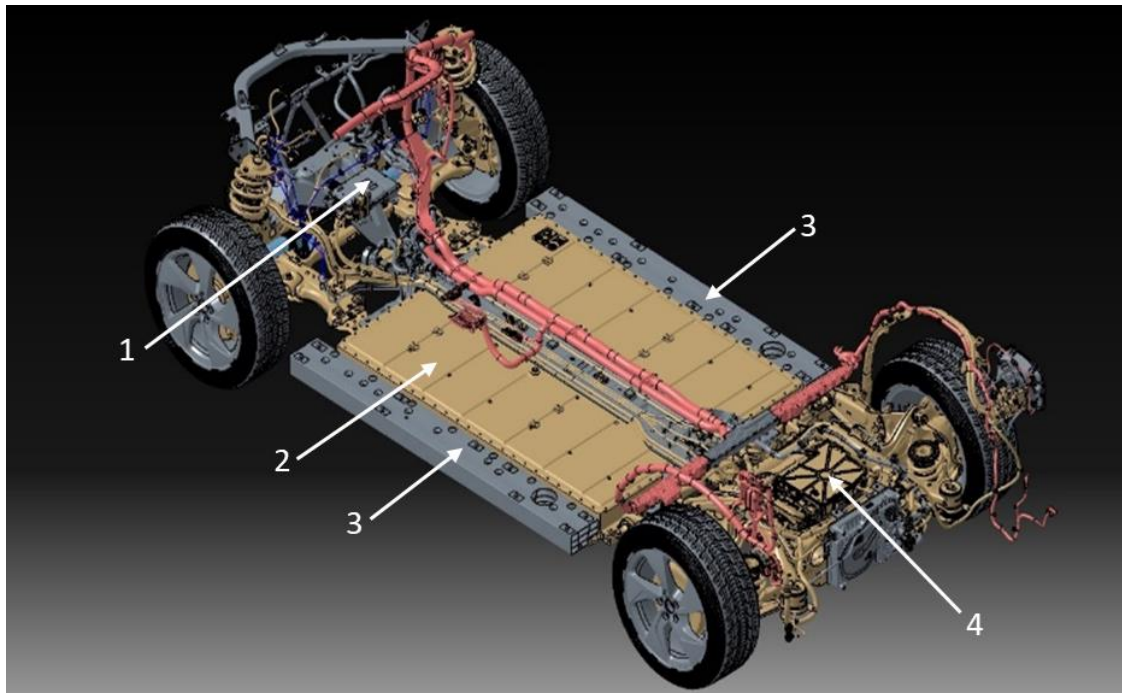

Fig. 1: Drive train for ID Buzz

- 1 - Battery energy management / power and control electronics for electric drive
- 2 - Lithium-ion high-voltage battery
- 3 - Crash elements
- 4 - Electric motor

Practical note

Modifications to the cooling and heating system and their components are not permitted.

Warning note

Special safety notes must be observed when working on electric vehicles. Failure to observe safety notes can result in a fatal electric shock.

Information

The required safety notes can be requested. Please contact us (see chapter 1.2.1 “Product and vehicle information for body builders”).

Warning note

The voltage within the high-voltage vehicle electrics and high-voltage battery is life-threatening!

Touching damaged orange-coloured high-voltage wires and high-voltage battery may result in a fatal electric shock. The high-voltage system may be active even if the ignition is switched off!

- Never carry out any work on the high-voltage vehicle electrics, orange-coloured high-voltage wires, high-voltage components or high-voltage battery. Work on the high-voltage system may only be performed by qualified specialist companies with appropriate accreditation to perform such work.
- Never modify, damage, dismantle or disconnect from the high-voltage system any of the orange-coloured high-voltage wires, high-voltage components or high-voltage battery.
- Work in close proximity to high-voltage components, high-voltage wires or high-voltage battery using machining, deforming or sharp-edged tools or heat sources, such as welding, soldering, hot-air or thermal bonding, may only be carried out if the voltage has been disconnected beforehand. The high-voltage battery cannot be de-energised. The high-voltage disconnection may only be performed by suitably qualified and trained specialist staff.
- If there is a fault in the high-voltage system, the drive is automatically deactivated where necessary, and a corresponding indicator may be displayed in the instrument cluster. Should this be the case, the drive will remain deactivated until the fault has been rectified by suitably qualified and trained specialist staff.
- The various Volkswagen policies must be observed when carrying out any work on the high-voltage vehicle electrics, including in particular on the orange-coloured high-voltage wires, high-voltage components or high-voltage battery.

2.6.2 Charging the high-voltage battery

Position of the charging socket:



Fig. 1: Rear right charging socket position

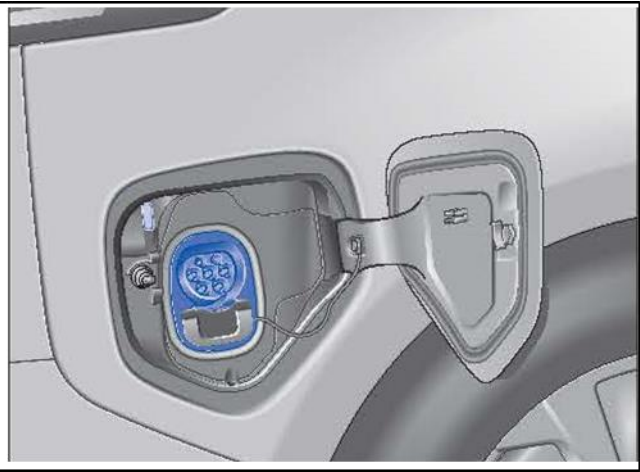

Fig. 2: DC/AC charging socket

The manual release for charging connector is located in the load compartment, behind the trim on the right:

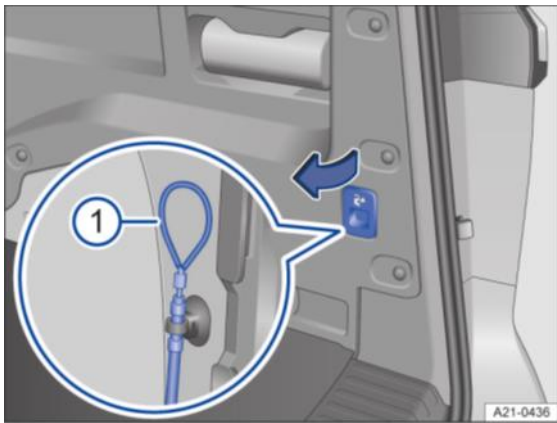

Fig. 3: Rear right side trim with cover for manual release mechanism for the charging connector

① Loop for manual release

Practical note

After the modification, access to the loop ① must be kept free in the load compartment and be able to be used by the vehicle user.

Information

Information about the manual release mechanism for the charging connector can be found in your vehicle's owner's manual.

Charging the vehicle with the emergency charging cable

Information

- In the case of an electrical extension independent of the base vehicle with an external feed (230 V), simultaneous use of the emergency charging cable (AC charging of the HV battery) and an additional external feed (230 V) may cause the emergency charging cable to disconnect (dropping the AC charge)!
- The reason for this is a potential difference of the PE lines (protective earth conductor) of the two feeds.
- The emergency charging cable has a monitored protective conductor and reacts to the potential difference.
- The remedy is to charge the vehicle at an electric charging station / wallbox without using the emergency charging cable.



Fig. 4: Emergency charging cable for mains power sockets (schematic diagram)

2.7 Add-ons/units

2.7.1 Roof carriers

Roof loads raise the centre of gravity of the vehicle and lead to a high dynamic axle load shift. Also, there is greater body lean when driving on rough roads and when cornering. The vehicle handling is significantly impaired.

For this reason, roof loads should be avoided if at all possible.

At least two base carriers are required to secure the roof load! In the case of very long objects, another base carrier must be used at the rear mounting point. The maximum permissible roof load of 100 kg must not be increased if another base carrier is added.

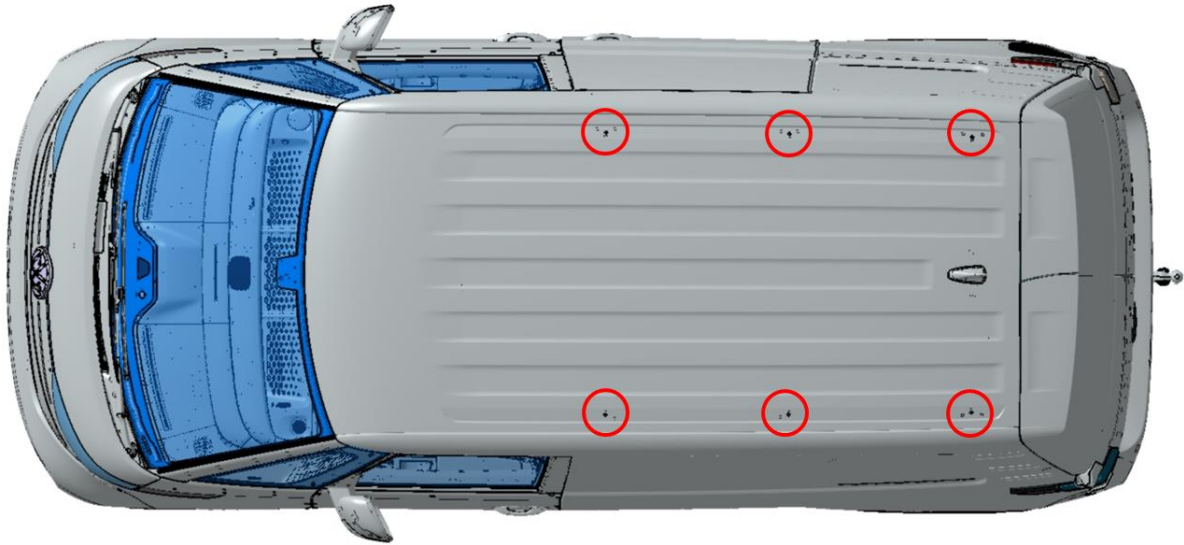

Fig. 1: Standard roof mounting points (schematic diagram)

2.7.2 Towing brackets

2.7.2.1 Maximum trailer weights

Only trailer towing brackets approved by the factory are permitted to be used as hitches.

Trailer towing brackets (ball hitches) can be ordered as optional equipment ex-works using the following PR number:

- 1M6 towing bracket, mechanically swivelling and electrically triggered
- Maximum trailer weight:
 - Unbraked 750 kg
 - Braked and with max. 12% hill climbing ability.
 - Rear-wheel drive (RWD) 4x2: 1,000-1,200 kg (depending on the engine)
- The maximum permitted draw bar weight is 75 kg
- The max. permitted gross combination weight specified in the papers must not be exceeded. The actual weight of the trailer load is not allowed to exceed the permitted gross weight of the towing vehicle.

2.7.2.2 Retrofitting a trailer towing bracket

Comply with the following points when retrofitting a trailer towing bracket:

- When fitting a trailer towing coupling in the EU, the specified installation dimensions and clearances in the current version of UNECE-R 55 must be observed. Any other applicable national regulations must be taken into account.
- The necessary clearance of the trailer behind the towing vehicle must be guaranteed (UNECE-R55).
- The vehicle shall be presented to a motor vehicle test centre with responsibility for this matter.
- No factory-fitted preparation for towing brackets is available.
- There are attachment points in the vehicle longitudinal members.
- The permitted gross combination weight (depending on the engine) must be ascertained prior to a retrofit.
- The standard towing bracket (swivelling, electrically extendable) is available as a retrofit kit, for vehicles already delivered, from the 2nd quarter of 2023. Please contact your Volkswagen Commercial Vehicles partner.

The retrofit measures are managed via PR No: #D8.

2.8 Raising the vehicle

1. With lifting platforms

The vehicle is only allowed to be raised at the lifting points provided. Refer to the corresponding Workshop Manual for information about the lifting points.

2. With a jack

Procedure and jacking points for the jack can be found in the owner's manual.

3 Modifications to closed bodies

3.1 Interior

The following points shall be observed without fail for conversions:

- The driver and front passenger airbag units, the airbags and the belt tensioners are pyrotechnical objects. Their handling, transport and storage are subject to legislation on potentially explosive substances, and the responsible public authority or government agency must therefore be notified. Purchase, transport, storage, installation and removal as well as disposal are only allowed to be performed by trained personnel in accordance with the corresponding safety regulations.
- Modifications in the cockpit area and above the shoulder line must meet the criteria for head impact tests in UNECE-R21. This applies in particular to the deployment zones of airbags (wooden trim, additional installations, mobile telephone retainers, bottle holders etc.).
- Painting or surface treatment of the dash panel, steering wheel impact absorber and the tear seams of the airbags is not permitted.
- The permitted centre of gravity position and axle loads are not allowed to be exceeded.
- The interior fitting-out shall be configured with soft edges and surfaces.
- Installations shall be manufactured from flame-retardant materials, and be firmly installed.
- Unhindered access to the seats shall be guaranteed.
- No projecting parts, corners or edges that could cause injuries are allowed to be located in the area of the seats.

3.1.1 Safety features

Warning note

In case of interventions by the body builder in the structure of the vehicle, such as

- modifications to the seats and consequently altered kinematics of the occupants in case of a crash
- modifications to the front body
- installations of parts in the vicinity of the exit openings and the deployment range of the airbags (see owner's manual of the vehicle)
- installation of third-party seats
- modifications to the doors

the safe function of the front airbag, side airbag and belt tensioners is no longer guaranteed. This could result in personal injuries.

Vehicle components that cause vibration must not be installed near the airbag control unit or the sensors.

Modifications to the floor structure in the area of the airbag control unit or the sensors are also not permitted.

The ID Buzz is equipped with head and side airbags in the 1st row of seats in all equipment lines. The Cargo version of the double bench seat on the passenger side has an optionally available side airbag.

In the 2nd and 3rd rows of seats, curtain airbags and seat belts are installed in the standard equipment for all vehicles.

Important note:

Please note that deactivation of the side airbag causes the airbag warning light in dash panel to light up continuously. Information about the deployment zones of the airbags can be found the vehicle owner's manual.

3.1.2. Retrofitting and removal of standard seats

- The strength data for seats available ex works is only valid in conjunction with the series attachment system.
- It is not possible to retrofit additional standard seats.
- If necessary, the functions of the airbags with belt tensioners and the seat-occupied recognition system for the front passenger seat can be deactivated by the Volkswagen authorised workshop.

3.1.2.1 Seat-occupied recognition system

The vehicle is equipped with a seat-occupied recognition system in all seats (driver's compartment/passenger compartment).

Warning note

When the seat belts and seats are re-fitted, the prescribed bolts must be used and tightened to the original torque. You will find detailed information on torques in the workshop manuals.

Only fit seat covers or protective covers that have been expressly approved for use in this vehicle. When unsuitable seat covers are used, the airbags in the backrests cannot deploy optimally to protect the occupants.

Information

Volkswagen AG workshop manuals and workshop information can be downloaded from the Internet at **erWin*** (Electronic Repair and Workshop Information from Volkswagen AG):

<http://erwin.volkswagen.de/erwin/showHome.do>

Or contact your Volkswagen Commercial Vehicles partner.

*Information system from Volkswagen AG, subject to payment

3.1.2.2 Installation of aftermarket product seats or use of standard seats deviating from the standard seating

As an alternative to the instructions in chapter 3.1.2, seats can also be installed with the following prerequisites:

- The strength data for seats available ex works is only valid in conjunction with the series attachment system.
- A seat deviating from the standard seating must be equipped with 3-point belts. Seat units without seat belts, or with two-point belts are not permitted.
- Seats and safety belts and their fastenings must be tested or approved in accordance with the laws, directives and approval regulations that apply in the countries of registration.
- It is essential not to exceed the height of the centre of gravity (H-point) when retrofitting seats. Refer to the build dimension drawings for more information and current documentation regarding the position of the H-point.
- If seat belts and belt buckles other than those available ex works are installed, ensure that all registration-related regulations are observed. (Please also refer to chapter 2.4.2.1 “Belt anchors”.)

Warning note

Seats must not be attached to the wheel housing. This also applies to wheel housings that are lowered. Otherwise damage could be caused to the vehicle (e.g. wheel housing and tyres) and accidents could result.

If seats other than those available from the factory are installed with factory seat belts, only belt locks that fit with the buckles on the factory seat belts may be used.

Otherwise the seat belt cannot be locked in the belt lock as intended and persons could be injured in the event of an accident.

Practical note

Modifications to the original series production condition can result in the withdrawal of type approval.

Country-specific laws, directives and approval regulations shall be observed!

3.1.3. Changes to the roof of the ID Buzz / ID Buzz Cargo

If changes are made to the roof structure of the ID Buzz / ID Buzz Cargo, the following points must be observed:

- The all-round concept must be retained, and adequate replacement rigidity must be guaranteed.
- The replacement rigidity of the new roof structure shall correspond to that of the standard roof.
- Impairment of the function of the rain/light sensor as well as the front camera in the windscreen, e.g. due to overhangs, is not permitted.
- Attachments similar to the roof rack are possible for subsequent attachment of add-ons.
- Following all conversion and installation work on the vehicle, surface and corrosion protection must be checked at the affected points and reworked as necessary.

Information

You will find further information on body assembly work on the Internet at **erWin*** (Electronic Repair and Workshop Information from Volkswagen AG):
<http://erwin.volkswagen.de/erwin/showHome.do>

*Information system from Volkswagen AG, subject to payment

3.1.4 Subsequent roof cut-outs

Roof cut-outs as a preparation for subsequent mounting of tilting, pop-up and high roofs are currently not available ex works.

Roof cut-outs are only possible between the cross struts and the side roof frames (see Fig.1 for details).

No roof loads according to chapter 2.3.1 "Roof loads" are possible if there is a roof cut-out that impinges on the cross struts.

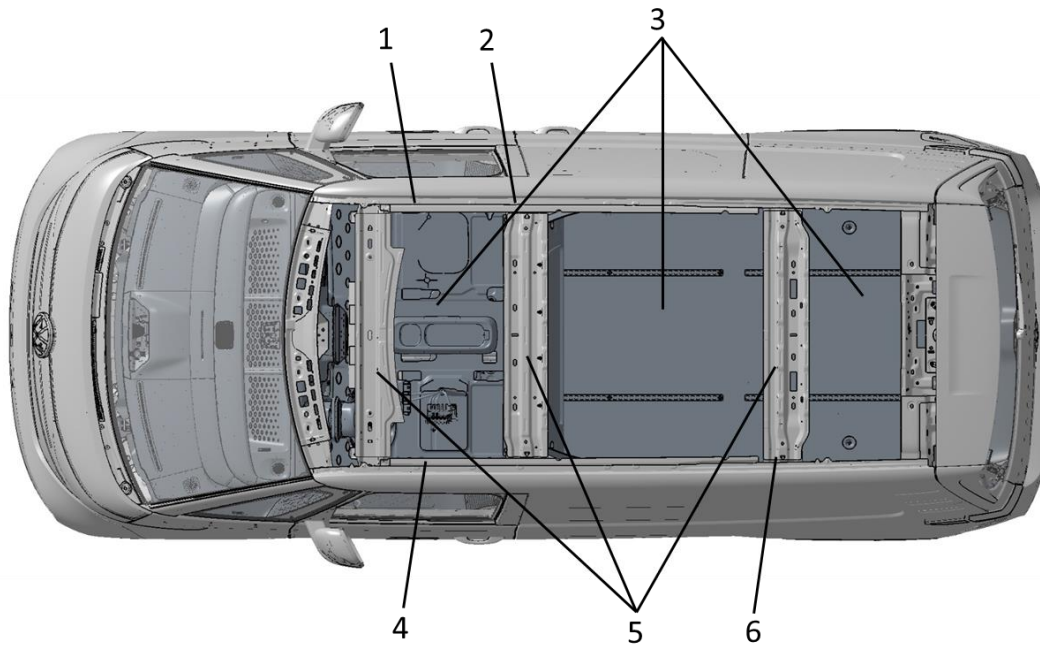

Fig. 1: Subsequent roof cut-outs (schematic diagram)

1 Roof frame right

2 B-pillar

3 The cut-out shall be provided with an all-round frame having a force-locking connection with the adjacent, weight-bearing parts (cross struts and roof frame).

4 Roof frame left

5 Roof bow

6 C-pillar

For more information about the conversion, see the following chapters:

- 2.2.1 “Permitted weights and unladen weights”
- 3.1.3 “Changes to the roof of the ID Buzz / ID Buzz Cargo”
- 3.1.6 “Subsequent installation of windows”
- 3.1.7 “Modifying the partition wall / forced ventilation”

Information

You will find further information on body assembly work on the Internet at **erWin*** (Electronic Repair and Workshop Information from Volkswagen AG):
<http://erwin.volkswagen.de/erwin/showHome.do>

*Information system from Volkswagen AG, subject to payment

Warning note

Processing the roof frame in the area of the head airbag is not permitted!

3.1.5 Side wall cut-outs

The structure and floor panel of the ID Buzz / ID Buzz Cargo form a self-supporting unit. Weight-bearing parts of this self-supporting unit are not allowed to be removed without replacement. Partitions have no function with respect to body stiffness. They can be modified as far as removing them entirely.

Cut-outs for windows, flaps, ventilation openings etc. are only allowed to be made between the weight-bearing parts (pillars, roof frame and floor). Weight-bearing parts are not allowed to be cut into or weakened. The cut-outs must be provided with a continuous frame which has a force-locking connection to the adjacent weight-bearing parts.

Warning note

Processing the roof frame in the area of the head airbag is not permitted!

Information

You will find further information on body assembly work on the Internet at **erWin*** (Electronic Repair and Workshop Information from Volkswagen AG):
<http://erwin.volkswagen.de/erwin/showHome.do>

*Information system from Volkswagen AG, subject to payment

3.1.6 Subsequent installation of windows

If windows are retrofitted in the side panel and/or sliding door of the ID Buzz Cargo, the following points must be observed:

- The erWin* Workshop Manual for the ID Buzz must be observed.
- The cut-out may only be made in an area that is a single sheet thickness.
- No weight-bearing parts are allowed to be cut into or weakened.
- The existing supporting adhesive between the body flange and the inside of body must be removed and replaced with a suitable body adhesive. Alternatively, body panel and flange joined to the body flange by spot welding.
- The strength lost due to the cut-out in the body panel, must be restored. To do this, it is advisable to use the standard glass panel of the ID Buzz with an adhesive system approved by Volkswagen.
- Observe the regulations for exterior design that apply in the countries of registration.

Information

For detailed instructions about the installation and removal of windows, refer to the Workshop Manuals of Volkswagen AG on the Internet under **erWin*** (Electronic Repair and Workshop Information from Volkswagen AG):
<http://erwin.volkswagen.de/erwin/showHome.do>

*Information system from Volkswagen AG, subject to payment

3.1.7 Modifying the partition wall/forced ventilation

Partitions have no function with respect to body stiffness. Partition walls can be removed entirely or in part in the panel van unless this is not allowed by accident prevention regulations or country-specific regulations. Any sharp edges resulting from removing the partition wall must be covered by taking suitable measures, e.g. edge protection sections (see Chapter 1.2.9 "Accident prevention").

The following partitions are available ex works as special equipment for the Cargo variant:

PR no.	Description
3CF	Partition without window and without load-through hatch
3CG	Partition with fixed window and without load-through hatch
3CM	Partition without window and with load-through hatch
3CT	Partition with fixed window and with load-through hatch

If installing alternative partitions, make sure that the selected forced ventilation cross sections correspond to those of the factory-fitted partition.

This is important in several respects:

- Closing comfort of the doors
- Possible flow rate of the heating blower
- Pressure equalisation on airbag deployment

The installed partition should have a factory label for clear identification.

If the partition is located behind the first seat row (driver's compartment), bear the possible seat adjustment range in mind. It is recommended to use the standard contact points and connecting elements.

The partition should be adequately stable and acoustically insulated with regard to acoustic comfort.

The strength of the partition must be validated according to DIN ISO 27956, irrespective of the country in which the vehicle is to be marketed. Although validation according to this standard is not legally binding, it is a requirement of trade associations if the vehicle is used for commercial purposes.

You will find further information on the standard contact points as well as installing and removing the standard partition in the Volkswagen AG Workshop Manuals.

Information

Volkswagen AG Workshop Manuals and workshop information can be downloaded from the Internet via **erWin*** (Electronic Repair and Workshop Information from Volkswagen AG):
<http://erwin.volkswagen.de/erwin/showHome.do>

*Information system from Volkswagen AG, subject to payment

3.1.8 Lashing rails

To ensure the secure attachment of cargo and fittings, ordering the lashing rails available as optional equipment from the factory is recommended in addition to the fastening rings. The following equipment is available:

PR no.	Description	Max. permitted nominal pulling force [daN]*
IH1	C-rails on the side panel and storage bag	150
IH2	C-rails on the partition	150
6L2	C-rails on side wall and partition	150
6L6	C-rails on side wall	150

*1 daN (Decanewton) equals 10 N

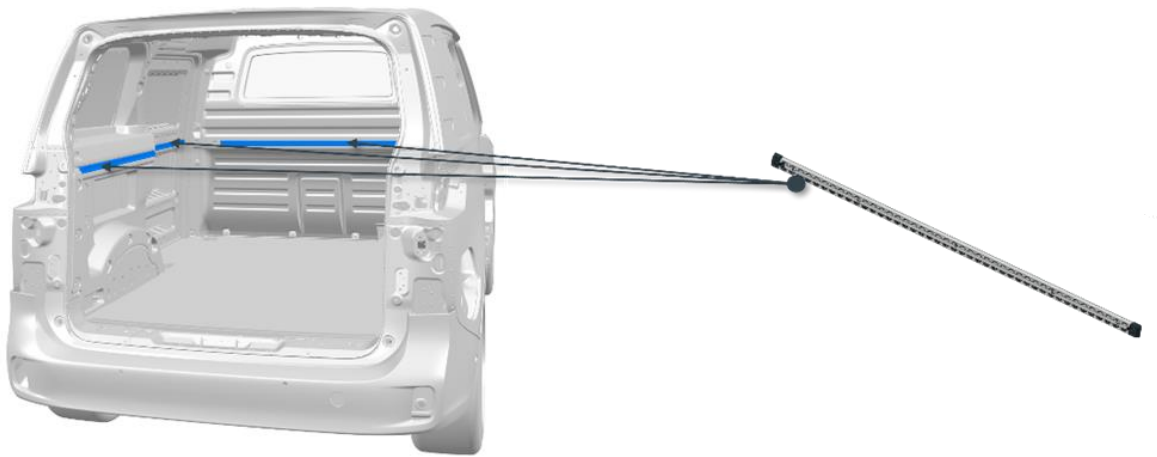

Fig. 1: Rail partition assembly (lashing rails on the partition and the side parts)

Practical note

When securing cargo, and when using the lashing rails and the fastening rings fitted ex-works, please observe the information in your vehicle's owner's manual.

3.1.8.1 Retrofitting lashing rails

Retrofitting of the lashing rail production parts:

1. On the partition:

The lashing strip is attached to the partition with special screws directly at the separation between upper and lower part.

2. In the middle of the side wall:

Screw connections are made directly through the trim panel into the body.

3. On the rear left/right side walls:

A special rework (cut-outs) on the trim and the installation of a special holder for the connection between the lashing rail and the body are required.

For more information, please contact your Volkswagen Commercial Vehicles dealership.

Practical note

The retrofitting of lashing rails may only be carried out in the areas of the partition wall and the vehicle side wall provided for this purpose.

Information

Volkswagen AG workshop manuals and workshop information can be downloaded from the Internet at **erWin*** (Electronic Repair and Workshop Information from Volkswagen AG):

<http://erwin.volkswagen.de/erwin/showHome.do>

*Information system from Volkswagen AG, subject to payment

3.1.9 Universal floor

In addition to the standard flooring, a universal wooden floor with lashing rails (PR no. 5BM) is available ex works as additional equipment for the ID Buzz Cargo.

In combination with a partition, the universal wooden floor is intended for the commercial transport of goods or for the installation of a workshop or shelf system but cannot be used for the installation of seating systems.

The wooden floor consists of a base plate made out of plywood, which is installed floating in the vehicle floor. The base plate is fixed by plate-shaped mounting elements in the positions of the original lashing points and additional points in the body. The original lashing points are still usable as such.

In addition, the floor-mounted cabinet systems from the various manufacturers must also be fastened on the sides. The side mounting of the rack and cabinet installations to the body must be carried out in accordance with the requirements of the rack and cabinet manufacturer.

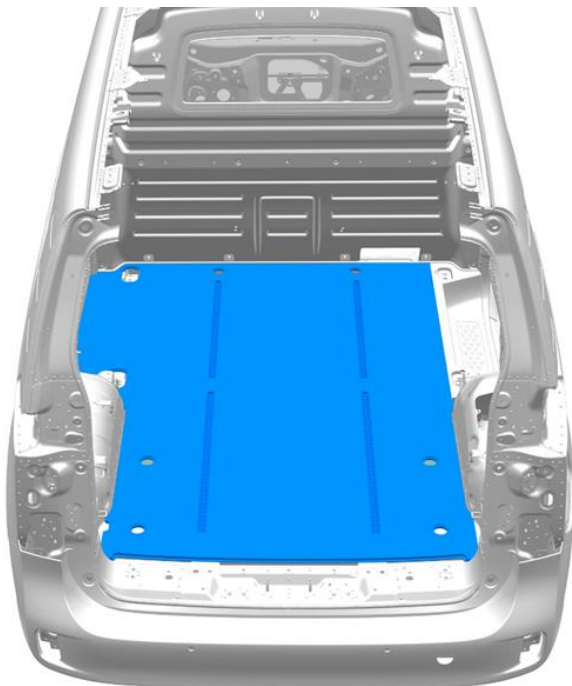

Fig. 1: Universal wooden floor with lashing rails, shown here: Cargo version with the sliding door on the right.

PR no.	Description	Max. permitted nominal pulling force [daN]*
5BM	C-rails in the universal floor	350
Standard	Fastening rings in the vehicle floor	350
Standard	Fastening rings on the wheel housing / sliding door opening	130

*1 daN (Decanewton) equals 10 N

Practical note

When securing cargo, and when using the lashing rails in the vehicle floor and the fastening rings fitted ex-works, please observe the information in your vehicle's owner's manual.

Please also note that the crash behaviour of installations depends on the connection to the vehicle floor, the side panels, and the distribution of the loads.

Please also comply with the following chapters:

- 3.1.10 "Shelf installation / workshop installation"
- 1.3.2 "Modifications to the vehicle"

3.1.10 Shelf installation / workshop installation

For shelf and workshop installations, the following points must be observed:

1. Selection of a suitable base vehicle (gross vehicle weight rating, running gear, equipment)
2. Driver's compartment and load compartment should be separated by means of a retaining device (partition, load guard) according to DIN ISO 27956.
3. The maximum permitted weights and axle loads of the base vehicle must be observed (see 2.2.1 "Permitted weights and kerb weights")
4. The installation should take place in a way that ensures that the forces induced are evenly distributed.
5. The permissible forces with which the fastening rings and the lashing rails can be loaded can be found in the current owner's manual.
6. The maximum load of drawers and shelves (taking dynamic forces into account) must be marked or indicated in the owner's manual. The owner's manual must be provided with the vehicle.
7. Assembly, maintenance and Owner's Manuals specifying the load limits should accompany the modified vehicle.
8. The vehicle structure must not be weakened by the installed components in the event of an accident.
9. The regulations and standards for load securing in the countries of registration must be observed.
10. The equipment must be designed to be crash-proof.
11. All corners and edges of the installations with which the user can come into contact must be designed with sufficiently large radii and chamfers to avoid injury.
12. Following all work to the body, drilling chips should be removed and corrosion protection measures should be performed. (see chapter 2.3.2 "Modifications to the body").
13. The requirements of the body builder guidelines for electrical wiring and fuses must be observed:
14. During installation and conversion no electric wires or other components of the base vehicle (e.g. fuel tank, brake lines) must be damaged.
15. Conversion should only be performed by trained specialist personnel.
16. "Sufficient ventilation" of the load compartment must be ensured in vehicles intended for the transportation of gas cylinders for work purposes. Diagonal ventilation, usually from the front at the top (roof), to the rear at the bottom (floor, or side wall at the bottom) is considered "sufficient".

For more information about the conversion, see the following chapters:

- 1.3.2 “Modifications to the vehicle”
- 3.1.8 “Lashing rails”
- 3.1.9 “Universal floor”

Information

In addition to the fastening rings in the body, the lashing rails on the side wall, the wooden floor in the load compartment or the universal floor with lashing rails, which are available as an option, are also to be used for the installation and secure fastening of shelves and workshop installations.

Practical note

Permanent installations increase the kerb weight of the vehicle.

Warning note

All relevant safety regulations for the transport of gas cylinders must be complied with.

4 Implementations of special bodies

4.1 Motor vehicles for the transport of persons with disabilities (KMP)

Information

Information on special installations for motor vehicles that are used to transport persons with impaired mobility can be found on the Volkswagen AG web page at:

<https://www.volkswagen-nutzfahrzeuge.de/de/modelle/branchenloesungen-und-umbauten/menschen-mit-behinderung.html>

4.1.1 Base vehicle equipment

When planning the special vehicle, select the equipment of the base vehicle according to the requirements of the future application (see also chapter 1.3.1 “Selecting the base vehicle”).

Please note that certain conversions are only allowed to be used by people with corresponding entries in their driving licence.

Practical note

If the driver does not leave the vehicle through the driver or front passenger door, error messages may be generated after several driving cycles due to the safety concept. For this reason, Volkswagen recommends briefly opening and closing the driver's door after unbuckling the seat belt when leaving the vehicle in order to avoid the entries in event memory.

Before using the vehicle, please familiarise yourself with all functions and special features of the vehicle by carefully reading the owner's manual. If you have any questions, please contact your Volkswagen authorised workshop.

4.1.2 Notes on installing manual operating devices for the foot brake

- Do not modify the brake pedal when installing manual operating devices. Select a clamped solution for connecting the manual operating device.
- The operating travel of the manual operating device must also be sufficient for a blocking braking, with reserve travel for a circuit failure.
- If a manual operating device is used for the accelerator and brake, the standard pedals must be covered by suitable means.

4.1.3 Deactivating the airbag/belt tensioner system

The customer service workshop can also deactivate/reprogram the driver airbag/belt tensioner in exceptional cases, e.g. for drivers with a disability (with entry in the driving licence), if there is insufficient distance to the steering wheel or if a smaller steering wheel for wheelchair users is fitted (self-drive) and no airbag can be installed. For more information, please contact Volkswagen customer service.

5 Technical data

5.1 Build dimension drawings

Please refer to our build dimension drawings for the dimensions of the new ID Buzz.

They are available for download in DXF, TIFF and PDF format from the Volkswagen AG CustomizedSolutionPortal. All files (except PDFs) are packed as Zip archives. The files can be unpacked using Winzip (PC) or Ziplt (MAC).

Information

Current build dimension drawings are available for download from the CustomizedSolutionPortal of Volkswagen AG under the “Technical drawings” menu option.

5.2 Diagrams (foil templates)

Vehicle views of the ID Buzz in 1:20 scale are available for download in TIF, DXF and EPS format to help you create diagrams. All files are packed as Zip archives. The files can be unpacked using Winzip (PC) or ZipIt (MAC).

Information

Current diagrams are available for downloading from the CustomizedSolutionPortal of Volkswagen AG under the “Foil templates” menu item.

5.3 Current flow diagrams

For detailed information about this topic, refer to the workshop manuals and circuit diagrams of Volkswagen AG.

Information

Volkswagen AG workshop manuals and circuit diagrams can be downloaded from the Internet at **erWin*** (Electronic Repair and Workshop Information from Volkswagen AG):
<http://erwin.volkswagen.de/erwin/showHome.do>

*Information system from Volkswagen AG, subject to payment

5.4 CAD models

As a registered body builder, you can receive 3-D data models in the formats CATIA V.5 and STEP for design purposes.

Information

The available 3D data can be found on the CustomizedSolutionPortal of Volkswagen AG under "Technical information/CAD data"*.

*Registration required.

6 Weights (masses)

When ordering your vehicle, please note that the kerb weight increases when additional equipment is selected and the available payload capacity is therefore reduced.

Due to the continual changes to the base vehicle, all vehicle weights are available via the country-specific sales documents on the Internet or via the CustomizedSolution Portal (www.customized-solution.com).

We recommend determining the definitive kerb weight of the entire vehicle by weighing before the conversion.

For further questions, please contact your Volkswagen Commercial Vehicles dealer, your importer or our Customer Care (see chapter 1.2.1.1 "Contact in Germany", 1.2.1.2 "International contact").

Practical note

For masses/dimensions, the following weight tolerances apply:

- 3% for vehicle classes M/N (except vehicles with special intended use)
- 5% for vehicles with special intended use

7 Homologation

7.1 Notes on homologation of modifications and conversions

Amendments to legislation from 1 January 2022 Regulation (EU) 2018/858 EU and national (Art. 44 and Art. 45)

Affected: vehicle classes M1, N1

For complete vehicles completed ex works at the OEM, the following applies:

Complete vehicles that have been modified with add-ons/conversions after completion ex works and before initial registration must resubmit CO₂/consumption values for the second stage.

These can be identified using the WLTP calculator in accordance with the available homologations.

Options for calculating weight changes are available for vehicles with light-duty approval. The mass in the ready-to-drive state must be taken into account. If individual values are not available for the respective conversion, a type approval can be applied for in coordination with the technical service / regulatory authority.

The vehicles are available ex works with full CoC* and light-duty or heavy-duty approval in accordance with WLTP. The maximum permissible mass after the conversion can be determined using the WLTP calculator. Valid for the approved drive variants (see offer for countries). The values for the maximum vehicle weights depend on the drive/equipment combination of the base vehicle and the conversion type.

*CoC Certificate of Conformity

Information

For all conversions carried out on vehicles with different drive variants and light-duty or heavy-duty approval for which no values can currently be generated using the WLTP calculation tool, and all conversions affecting aerodynamics, please contact your responsible technical service and check whether individual approval or multi-stage type approval is possible.

8 Listings

8.1 List of changes

Changes to the body builder guidelines compared to the data status of September 2023.

Chapter no.	Chapter heading	Scope of change
1	General information	
1.1	Introduction	
1.1.1	Concept of this Owner's Manual	
1.1.2	Means of representation	
1.1.3	Vehicle safety	
1.1.4	Operational safety	
1.1.5	Note on copyright	
1.2	General notes	
1.2.1	Product and vehicle information for body builders	
1.2.1.1	Contact in Germany	
1.2.1.2	International contact	
1.2.1.3	Electronic Repair and Workshop Information from Volkswagen AG (erWin)	
1.2.1.4	Genuine parts online ordering portal	
1.2.1.5	Online owner's manual	
1.2.1.6	European Type Approval (ETA) and Certificate of Conformity (CoC)	
1.2.1.7	Worldwide Harmonised Light Vehicles Test Procedure (WLTP)	
1.2.1.8	WLTP homologation for upgrades/conversions	
1.2.1.9	Manufacturer's declaration	
1.2.2	Body builder guidelines, consulting	
1.2.2.1	Letter of non-objection	
1.2.2.2	Application for the letter of non-objection	
1.2.2.3	Legal entitlements	
1.2.3	Warranty and product liability of the body builder	
1.2.4	Ensuring traceability	
1.2.5	Badges	
1.2.5.1	Positions on rear of the vehicle	
1.2.5.2	Appearance of whole vehicle	
1.2.5.3	Non-Volkswagen badge	
1.2.6	Recommendations for vehicle storage	Chapter updated
1.2.7	Compliance with environmental rules and regulations	
1.2.8	Recommendations for inspection, maintenance and repair	
1.2.9	Accident prevention	
1.2.10	Quality system	
1.3	Planning bodies	
1.3.1	Selecting the base vehicle	Link updated
1.3.2	Vehicle modifications	

Chapter no.	Chapter heading	Scope of change
1.3.2.1	Modifications to the underbody area of the high-voltage battery and the drive	
1.3.2.2	Body / side panels	
1.3.2.3	Electrical system	
1.3.3	Vehicle acceptance	
1.4	Special equipment	Link and chapter reference updated
2	Technical data for planning	
2.1	Base vehicle	
2.1.1	Vehicle dimensions	
2.1.1.1	ID Buzz Cargo basic data	
2.1.1.2	Overhang angle and breakover angle of Cargo	
2.1.1.3	ID Buzz basic data	
2.1.1.4	Ramp angle and breakover angle	
2.2	Running gear	
2.2.1	Permitted weights and unladen weights	
2.2.2	Turning circle	
2.2.3	Authorised tyre sizes	
2.2.4	Modifications to axles	
2.2.5	Modifications to the steering system	
2.2.6	Brake system and brake control system ESC	
2.2.6.1	General notes	
2.2.6.2	Routing of additional cables	
2.2.7	Modification of springs, suspension mounting, dampers	
2.2.8	Wings and wheel housings	
2.3	Body-in-white	
2.3.1	Roof loads/vehicle roof	
2.3.1.1	Dynamic roof loads	
2.3.1.2	Static roof loads	
2.3.2	Modifications to the body-in-white	
2.3.2.1	Screw connections	
2.3.2.2	Welding work	
2.3.2.3	Welded connections	
2.3.2.4	Selection of welding process	
2.3.2.5	Spot welding	
2.3.2.6	Shielding gas hole spot welding	
2.3.2.7	Tacking	
2.3.2.8	Welding is not allowed	
2.3.2.9	Corrosion protection after welding	
2.3.2.10	Corrosion protection measures	
2.3.2.11	Planning measures	
2.3.2.12	Component design measures	
2.3.2.13	Coating measures	
2.3.2.14	Work on the vehicle	
2.4	Interior	
2.4.1	Modifications in the area of airbags	
2.4.2	Modifications in the area of seats	

Chapter no.	Chapter heading	Scope of change
2.4.2.1	Belt anchors	
2.4.3	Forced ventilation	
2.4.4	Acoustic insulation	
2.4.5	eCall Emergency System	
2.5	Electrics/electronics	
2.5.1	Lighting	
2.5.1.1	Vehicle lighting devices	
2.5.1.2	Adjusting headlights	
2.5.2	Electrical system	
2.5.2.1	Electrical wiring/fuses	
2.5.2.2	Additional electrical circuits	
2.5.2.3	Fuse carrier with emergency cut-out connection	Chapter updated, heading changed
2.5.2.4	Electromagnetic Compatibility	
2.5.2.5	Mobile communication systems	
2.5.2.6	CAN bus	Practical note updated
2.5.3	Electrical interface for special vehicles	
2.5.3.1	General information on the interface for special vehicles	Chapter added
2.5.3.2	Electrical interface for special vehicles / electrical terminal strip IS1	Chapter created and added
2.5.4	Vehicle battery	
2.5.4.1	230 V inverter	
2.5.6	Earth points	
2.6	Battery and drive for electric vehicle	Chapter revised
2.6.1	High-voltage system	Chapter revised
2.6.2	Charging the high-voltage battery	
2.7	Add-ons/units	
2.7.1	Roof carriers	
2.7.2	Towing brackets	
2.7.2.1	Maximum trailer weights	
2.7.2.2	Retrofitting a trailer towing bracket	
2.8	Raising the vehicle	
3	Modifications to closed bodies	
3.1	Interior	
3.1.1	Safety features	
3.1.2	Retrofitting and permanent removal of standard seats in the passenger compartment	Chapter updated, heading changed
3.1.2.1	Seat-occupied recognition system	Chapter updated, heading changed
3.1.2.2	Installation of aftermarket product seats or use of standard seats deviating from the standard seating	Chapter updated
3.1.3	Modifications to the roof	
3.1.4	Roof cut-outs	Note: Other chapter numbers changed
3.1.5	Side wall cut-outs	
3.1.6	Subsequent installation of windows	Chapter repositioned
3.1.7	Modifying the partition wall / forced ventilation	Chapter numbering adapted.
3.1.8	Lashing rails	Chapter numbering adapted.
3.1.8.1	Retrofitting lashing rails	Chapter numbering adapted.
3.1.9	Universal floor	Chapter numbering adapted.

Chapter no.	Chapter heading	Scope of change
3.1.10	Shelf installation	Chapter numbering adapted.
4	Implementation of special bodies	
4.1	Vehicles for conveying mobility-challenged persons	
4.1.1	Base vehicle equipment	
4.1.2	Notes on installing manual operating devices for the foot brake	
4.1.3	Deactivating airbags	
5	Technical data	
5.1	Build dimension drawings	Link updated
5.2	Diagrams (foil templates)	Link updated
5.3	Current flow diagrams	
5.4	CAD models	Link updated
6	Weight tables	
7	Homologation	
7.1	Notes on homologation of modifications and conversions	Chapter revised
8	Listings	
8.1	List of changes	
Last page	Address, mailroom slot	

Body builder guidelines

The ID Buzz

Body builder guidelines

Subject to change without notice

Edition April 2024

Internet:

<https://www.volkswagen-nutzfahrzeuge.de>

www.customized-solution.com

Consulting for body builders in Germany is available from the listed address.

Volkswagen Commercial Vehicles

Brieffach 2949

Postfach 21 05 80

D-30405 Hannover