



Converter guidelines

The Caddy (from model year 2021)



Table of contents

1	General information	6
1.1	Introduction	6
1.1.1	Concept of this Owner's Manual	6
1.1.2	Means of representation	7
1.1.3	Vehicle safety	8
1.1.4	Operational safety	9
1.1.5	Note on copyright	9
1.2	General information	10
1.2.1	Product and vehicle information for Converters	10
1.2.1.1	Contact in Germany	10
1.2.1.2	International contact	10
1.2.1.3	Electronic repair and workshop information from Volkswagen AG (erWin*)	11
1.2.1.4	Genuine Parts Online Ordering Portal*	11
1.2.1.5	Online Owner's Manual	11
1.2.1.6	Homologation	12
1.2.1.7	European Type Approval and EC Certificate of Conformity	13
1.2.1.8	Worldwide Harmonised Light Vehicles Test Procedure (WLTP)	13
1.2.1.9	Manufacturer's declaration	14
1.2.2	Converter guidelines, consulting	14
1.2.2.1	Letter of non-objection	14
1.2.2.2	Application for the letter of non-objection	16
1.2.2.3	Legal entitlements	16
1.2.3	Warranty and product liability of the Converter	17
1.2.4	Ensuring traceability	18
1.2.5	Badges	18
1.2.5.1	Positions on rear of the vehicle	18
1.2.5.2	Appearance of whole vehicle	18
1.2.5.3	Non-Volkswagen trademarks	18
1.2.6	Recommendation for vehicle storage	18
1.2.7	Compliance with environmental rules and regulations	20
1.2.8	Recommendations for inspection, maintenance and repair	21
1.2.9	Accident prevention	21
1.2.10	Quality system	22
1.3	Planning bodies	23
1.3.1	Selecting the basic vehicle	23
1.3.2	Vehicle modifications	24
1.3.3	Vehicle acceptance	25
1.4	Special equipment	26
2	Technical data for planning	27
2.1	Basic vehicle	27
2.1.1	Vehicle dimensions	27
2.1.1.1	Basic data of Caddy Cargo	28
2.1.1.2	Basic data of Caddy	30
2.1.2	Ramp angle and breakover angle	33
2.1.3	Vehicle centre of gravity	34
2.1.4	Bodies with a high centre of gravity	34
2.1.5	Determining the centre of gravity	35
2.1.6	Steerability – minimum front axle load	35
2.2	Running gear	36
2.2.1	Permitted weights and kerb weights	36

2.2.1.1 One-sided weight distribution	37
2.2.2 Turning circle	37
2.2.3 Approved tyre sizes	37
2.2.4 Modifications to axles.....	38
2.2.5 Modifications to the steering system	38
2.2.6 Brake system and brake control system ESC*	38
2.2.6.1 General information	38
2.2.6.2 Vehicle stability and ESC*	39
2.2.6.3 Influence of vehicle conversions on the function of ESC* brake regulation system	40
2.2.6.4 Routing additional lines along the brake hoses/brake lines.....	41
2.2.7 Modification of springs, suspension mounting, dampers	41
2.2.7.1 Rear axle running gear for heavy installations (retrofit kit, PR number UC5)	41
2.2.8 Wheel alignment settings	42
2.3 Body-in-white	43
2.3.1 Roof loads/vehicle roof.....	43
2.3.1.1 Dynamic roof loads.....	43
2.3.2 Modifications to the body-in-white.....	43
2.3.2.1 Bolted connections	44
2.3.2.2 Welding work.....	45
2.3.2.3 Welded connections.....	45
2.3.2.4 Selection of welding process.....	46
2.3.2.5 Resistance spot welding	46
2.3.2.6 Shielding gas plug welding	47
2.3.2.7 Tacking.....	48
2.3.2.8 Welding is not allowed	48
2.3.2.9 Corrosion protection after welding	48
2.3.2.10 Corrosion protection measures	48
2.3.2.11 Planning measures	49
2.3.2.12 Component design measures	50
2.3.2.13 Coating measures	50
2.3.2.14 Work on the vehicle.....	50
2.4 Interior	51
2.4.1 Modifications in the area of airbags	51
2.4.2 Modifications in the area of seats	51
2.4.2.1 Belt anchors.....	52
2.4.3 Forced ventilation vent.....	52
2.4.4 Acoustic insulation.....	52
2.5 Electrics/electronics.....	53
2.5.1 Lighting.....	53
2.5.1.1 Vehicle lighting systems	53
2.5.1.2 Mounting special lights.....	54
2.5.1.3 Additional luggage compartment light	54
2.5.2 Electrical system	55
2.5.2.1 Electrical wiring / fuses.....	55
2.5.2.2 Additional circuits	56
2.5.2.3 Retrofitting electrical devices.....	57
2.5.2.4 Electromagnetic compatibility	58
2.5.2.5 Mobile communication systems	59
2.5.2.6 CAN bus	59
2.5.2.7 Current and signal take-off of vehicle electrical system potentials.....	61
2.5.3 Electrical interface for special vehicles	62
2.5.3.1 General notes on the interfaces	62

2.5.3.2 230 V DC/AC converter (PR no. 9Z3, 9Z6).....	64
2.5.3.3 Customer-specific functional control unit (CFCU).....	66
2.5.4 Vehicle battery	69
2.5.4.1 Installation of additional battery	69
2.5.4.2 Intelligent external charging control	73
2.5.4.3 Parameterised* reactions on reaching certain second battery charge levels with second battery monitoring.....	74
2.5.5 Retrofitting of alternators.....	76
2.5.6 Driver assist systems.....	76
2.5.6.1 General overview.....	78
2.5.6.2 Electromechanical steering	78
2.5.6.3 Electronic Stability Control (ESC).....	79
2.5.6.4 Tyre Pressure Monitoring System (TPMS)	80
2.5.6.5 Front camera for driver assist systems.....	82
2.5.6.6 Rain/light sensor	83
2.5.6.7 Parking aids	83
2.5.6.8 Lane departure warning "Lane Assist"	85
2.5.6.9 Front assist / ACC	85
2.5.7 Earth points	87
2.6 Engine peripherals/drive train	88
2.6.1 Engine / drive train components	88
2.6.2 Drive shafts	88
2.6.3 Fuel system.....	88
2.6.3.1 CNG* fuel system.....	90
2.6.4 Exhaust system.....	91
2.6.4.1 Hybrid powertrain exhaust system (PHEV).....	94
2.6.4.2 4x4 drive exhaust system	95
2.6.5 SCR system (EU6).....	97
2.6.5.1 Installation position of the AdBlue® tank in the vehicle	97
2.6.5.2 Filling the AdBlue tank.....	98
2.7 Engine power take-off systems	100
2.7.1 Compatibility with base vehicle	101
2.7.2 Retrofitting air conditioning system	103
2.7.3 Retrofit load compartment cooling system	103
2.7.4. Specifications of genuine refrigerant compressor.....	104
2.7.4.1 Maximum cooling output	104
2.7.4.2 Weight of the refrigerant compressor.....	104
2.7.4.3 Pulley diameter of the refrigerant compressor	105
2.7.4.4 Specification of the poly V-belt	105
2.7.4.5 Connection dimensions of genuine refrigerant compressor	105
2.8 Add-ons/units.....	106
2.8.1 Roof carriers	106
2.8.2 Rear luggage carrier/rear ladders.....	107
2.8.3 Towing brackets	107
2.8.3.1 Maximum trailer weights.....	107
2.8.3.2 Retrofitting a trailer towing bracket	107
2.8.3.3 Clearance according to UN-R 55	107
2.9 Raising the vehicle	110
3 Modifications to closed bodies.....	111
3.1 Body-in-white/body.....	111
3.1.1 Side wall cut-outs	111
3.1.2 Subsequent installation of windows	112
3.1.3 Roof cut-outs.....	113

3.1.4 Modifications to the roof of the Caddy Cargo / Caddy	115
3.1.5 Modifying the partition wall/forced ventilation	116
3.1.6 Partition connection points.....	118
3.2 Interior	119
3.2.1 Safety features	119
3.2.2 eCall Emergency System	120
3.2.3 Seat retrofitting / seating with standard seats	120
3.3 Add-ons	121
3.3.1 Accessories	121
4 Implementations of special bodies.....	122
4.1 Motor vehicles for the transport of persons with disabilities (KMP)	122
4.1.1 Basic vehicle equipment	122
4.1.2 Selection of steering rack for conversions for people with disabilities	123
4.1.3 Notes on conversion solutions for the wheelchair transporter	123
4.1.4 Notes on installing manual operating devices for the foot brake:	125
4.1.5 Deactivating the airbag/belt tensioner system.....	125
4.2 Refrigerated vehicles	127
4.3 Shelf installation/workshop vehicles.....	128
4.3.1 Shelf and workshop installations	128
4.4 Emergency vehicles.....	130
4.5 Preparation for taxis and private hire cars.....	131
4.5.1 Preparation for taxis and private hire cars ex works.....	131
4.5.2 Pin assignment on CFCU* (input and output assignment / pins on CFCU*)	131
4.5.3 Function description	133
4.5.4 Programming according to customer requirements.....	135
4.6 Leisure vehicles.....	136
4.7 Vehicles for local and public authorities	137
4.8 Vehicles for couriers and logistics.....	138
4.9 Plug-in hybrid electric vehicle (PHEV)	139
4.9.1 High-voltage system	139
4.9.1.1 Power and control electronics for electric drive	140
4.9.1.2 Modifications to the underbody area of the high-voltage battery and the drive	140
4.9.2 12-V vehicle electrical system	144
5 Technical data.....	145
5.1 Dimension drawings	145
5.2 Diagrams (foil templates).....	146
5.3 Current flow diagrams	147
5.4 CAD models	148
6 Calculations	149
6.1 Determining the centre of gravity	149
6.1.1 Determining the centre of gravity in x-direction.....	149
6.1.2 Determining the centre of gravity in z-direction	151
7 Weights (masses).....	155
8 Notes on homologation of modifications and conversions	156
8.1 Availability with complete Certificate of Conformity ex works – light duty WLTP	156
8.2 Technical specifications.....	157
8.2.1 Permissible aerodynamic changes and min./max. weights apply to the following variants:	157
8.2.2 Permissible aerodynamic changes and max. dimensions	158
9 Listings.....	159
9.1 List of changes	159

1 General information

1.1 Introduction

These Converter guidelines provide Converters with important technical information which must be complied with when planning and manufacturing a body for road safety and operational reliability. The add-on, body, installation or conversion work required for this is referred to below as “body activities”.

Due to the large number of individual conversions and body types in the Converter industry, it is not possible for Volkswagen AG to foresee all possible changes, e.g. in driving behaviour, stability, weight distribution, centre of gravity of the vehicle and its handling characteristics which can occur as a result of work carried out on the body. Therefore, Volkswagen AG does not accept any liability for accidents or injuries arising from modifications of this kind made to its vehicles, especially if the changes have a negative effect on the vehicle as a whole. As a result, Volkswagen AG only accepts liability for its own design, production and instruction services. The Converter itself is obliged to ensure that its body activities are not faulty in themselves, and also that they cannot result in defects or dangers on the vehicle as a whole. The Converter must also ensure that the body work complies with the technical vehicle regulations and the applicable laws (in particular approval and registration processes). The Converter itself is liable in the event that this obligation is violated.

These Converter guidelines are intended for professional Converters. As a result, these Converter guidelines assume corresponding background knowledge. Note that some work (e.g. welding on load-bearing parts) is only allowed to be performed by appropriately qualified personnel. This requirement exists in order to avoid risks of injury and to achieve the quality needed in the body activities.

1.1.1 Concept of this Owner's Manual

The following Converter guidelines are divided into 9 chapters so that you can find information rapidly:

1. General information
2. Technical data for planning
3. Modifications to closed bodies
4. Implementations of special bodies
5. Technical data
6. Calculations
7. Weights (masses)
8. Notes on homologation of equipping and conversions
9. Listings

Information

For more information, see [chapter 1.2.1.1 “Contact”](#) and [chapter 1.2.2 “Converter guidelines, consulting”](#).

It is essential that the limit values selected in [chapter 2 “Technical data for planning”](#) are complied with and are used as the basis for planning.

1.1.2 Means of representation

The following means of representation are used in these Converter guidelines:

Warning note

A danger note draws your attention to possible accident or injury risks to which you or other persons might be exposed.

Environmental note

An environmental note provides you with information about environmental protection.

Practical note

This note draws your attention to the risk of possible damage to the vehicle, as well as to regulations and provisions to be observed.

Information

This note indicates additional information.

1.1.3 Vehicle safety

Warning note

Before assembling external bodies or power units, it is essential that you read the chapters in these Converter guidelines that are related to installation, as well as corresponding chapters in the instructions and information for the suppliers' power units and in the detailed Owner's Manual for the basic vehicle. Otherwise you will not be able to recognise dangers, and might expose yourself or others to danger.

We recommend that you use parts, power units, conversion parts or accessories that have been tested by Volkswagen AG for the corresponding vehicle type.

Have the vehicle's safety checked immediately if non-recommended parts, mechanical units, conversion parts or accessories are used.

Practical note

It is essential that you comply with European vehicle approval or UN R regulations, as well as national registration regulations and also technical vehicle regulations. This is because body activities on the vehicle can alter the vehicle type under registration regulations and the operating permit may be invalidated.

This applies in particular to:

Modifications which change the vehicle type approved in the operating permit

modifications which might be expected to endanger road users or

modifications which impair the exhaust or noise emissions characteristics

1.1.4 Operational safety

Warning note

Incorrect interventions in electronic components and their software may result in these no longer functioning. Due to the networking of electronics, systems that were not modified can be affected.

Malfunctions to the electronics can significantly impair the operational safety of the vehicle.

Have work on or modifications to electronic components performed by a qualified specialist workshop which has the necessary specialist knowledge and tools for performing the necessary work.

Volkswagen AG recommends a Volkswagen AG customer service workshop for this purpose.

Service by a qualified specialist workshop is essential, in particular for safety-relevant work and work on safety-relevant systems.

Some safety systems only operate when the engine is running. Therefore, do not switch the engine off when driving.

1.1.5 Note on copyright

The texts, pictures and data contained in these Converter guidelines are subject to copyright. This also applies to editions on CD-ROM, DVD or other media.

1.2 General information

The following pages contain technical guidelines for Converters and equipment fitters designing and mounting bodies. The Converter guidelines must be strictly adhered to when performing any modifications to the vehicle. The current version of the German edition of the Converter guidelines is the exclusive authority for the most up-to-date information.

This also applies to legal claims. Should the Converter guidelines include references to legal regulations, then no guarantee can be provided for the completeness and correctness of this content, or that it is up-to-date. Country-specific features can vary.

1.2.1 Product and vehicle information for Converters

1.2.1.1 Contact in Germany

If you have questions concerning vehicle models from Volkswagen Commercial Vehicles, you can contact us online on the Volkswagen AG portals (<https://www.customized-solution.com>) using one of the following methods:

Free hotline (from a German landline)	00800 2878 66 49 33 (00800-CUSTOMIZED)
Contact (email)	customizedsolution@volkswagen.de
Personal contacts	https://www.customized-solution.com/de/de/service-informationen/kundenbetreuung

1.2.1.2 International contact

Please contact the Converter's support personnel at the responsible importer for technical advice relating to Volkswagen Commercial Vehicles models and as a point of contact for conversions.

To find the contact person responsible for you, please register on the Volkswagen AG CustomizedSolution portal (<https://www.customized-solution.com>).

Help is available for the registration option using the "Help" menu option.

International hotline	+800 2878 66 49 33 (+800 CUSTOMIZED)
Email	customizedsolution@volkswagen.de
Personal contacts	https://www.customized-solution.com/en/en/service-information/customer-care

1.2.1.3 Electronic repair and workshop information from Volkswagen AG (erWin*)

Converters can access repair and workshop information, e.g.:

- Current flow diagrams
- Workshop manuals
- Maintenance
- Self-study Programmes

via the Electronic Repair and Workshop Information System from Volkswagen AG (erWin*).

Converters with Integrated Partner or Premium Partner status have access to discounted annual licenses, which can be applied for by going to My Customised Solution Portal/Requirements/Planning and Development. Converters in export with the Partner status receive information in this regard from their point of contact at the importer.

Information

Volkswagen AG repair and workshop information can be downloaded from the Internet at **erWin*** (Electronic Repair and Workshop Information from Volkswagen AG):

<https://erwin.volkswagen.de/erwin/showHome.do>

*Information system from Volkswagen AG, subject to payment

1.2.1.4 Genuine Parts Online Ordering Portal*

For the purchase of spare parts and for the research of Volkswagen Genuine Parts, our latest parts catalogues are available on the internet on the “Genuine Parts Online Ordering Portal”:

<https://www.partslink24.com>

Converters with Integrated Partner or Premium Partner status have access to discounted conditions.

All further information regarding direct purchasing of genuine parts can be found in the Customised Solution Portal under My Customised Solution Portal/Requirements/Delivery and Customer Service. The offer applies exclusively to the German market.

*Information system from Volkswagen AG, subject to payment

1.2.1.5 Online Owner’s Manual

Detailed information about the functions and handling of your vehicle can be found in your Owner's Manual which is enclosed with your vehicle ex-works. In addition to the hard copy of the owner’s manual, the following link and VIN number of the vehicle can be used to receive the owner’s manual in electronic form:

<https://www.volkswagen-nutzfahrzeuge.de/de/service-und-teile/bordbuch.html>

1.2.1.6 Homologation

Amendments to legislation from 1 January 2022 Regulation (EU) 2018/858 EU and national (Art. 44 and Art. 45)

Affected: all vehicle classes M1, N1 (light duty)

For complete vehicles completed ex works at the OEM, the following applies:

Complete vehicles that have been modified with add-ons/conversions after completion ex works at the OEM and before initial registration must resubmit CO₂/consumption values for the second stage.

These can be identified using the WLTP calculator in accordance with the available homologations.

Options for calculating weight and/or aerodynamic changes are available.

If individual values are not available for the respective conversion, a type approval can be checked in coordination with the technical service/regulatory authority.

Information

For all vehicles and/or engine-gearbox variants for which no values can currently be generated using the WLTP calculator, please contact your responsible technical service department and check whether individual approval or multi-stage type approval is possible.

Further information on this topic can be found in [chapter 8 “Notes on homologation of modifications and conversions”](#).

1.2.1.7 European Type Approval and EC Certificate of Conformity

Regulation (EU) 2018/858 of the European Parliament establishes the standard for the approval of motor vehicles and their trailers, and of systems, components and separate technical units intended for such vehicles.

Provisions were also adopted in this directive for the approval of vehicles produced in several stages: the multi-stage approval process. Accordingly, each manufacturer involved in the construction of a vehicle is itself responsible for the approval of modified or added scopes in its production stage.

The manufacturer may choose one of the four following methods:

- EU type approval
- EU type approval for small series
- National small series type approval
- Individual approval

CoC = Certificate of Conformity. A document that verifies the conformity of certain goods – and therefore also of vehicles and bodies – in accordance with the recognised (international) standards. The purpose of this Certificate of Conformity is to facilitate the approval of goods on international markets. As a result, the document is needed above all in import and export as part of the customs clearance procedure.

The manufacturer, the owner of an EU type approval or EU small series type approval, is obliged to provide a Certificate of Conformity with every vehicle which corresponds to an approved type. If you are planning to apply multi-stage type approval, an agreement must be concluded in accordance with the 2018/858/EU regulation. Please get in touch with us for information on this matter. (see [chapter 1.2.1.1 “Contact in Germany”](#) or [chapter 1.2.1.2 “International contact”](#))

1.2.1.8 Worldwide Harmonised Light Vehicles Test Procedure (WLTP)

New consumption values/ranges calculated in accordance with the new WLTP standards apply from September 2017 for new passenger cars entering the market and from September 2018 for new light commercial vehicles entering the market.

As of 1 September 2018, certified WLTP measurements must be available for all newly registered passenger cars. For light commercial vehicles with exhaust emission standard EU6 under Regulation EC 715/2007, the regulation will come into force one year later on 1 September 2019. 28+6 markets in Europe are affected by the WLTP.

WLTP stands for Worldwide Harmonised Light Vehicles Test Procedure. This is a worldwide standardised testing procedure for determining fuel consumption/electric range and exhaust emissions.

It is replacing the NEDC (New European Driving Cycle) test procedure that has been in force since 1992.

Unlike the NEDC, the WLTP takes into account individual special equipment and conversion solutions for weight, aerodynamics, electrical system requirements (no-load current) and rolling resistance which have an impact on the fuel consumption/electric range and exhaust emissions. This includes, in particular, modifications that result in a larger end face, a different radiator inflow area, a higher kerb weight for the vehicle or changes to the tyre size or the rolling resistance. Special equipment that consumes power, such as the air conditioning system or seat heating, still remains switched off for the duration of the test procedure.

Before initial approval, conversions or add-ons where WLTP is relevant can be made if they are approved by way of an individual approval or multi-stage type approval.

The Volkswagen type approval can be used for the multi-stage type approval for vehicles with conversions or add-ons that remain within the ISC parameters/maximum technical specifications for bodies. If the body or conversion is outside the ISC parameters/maximum technical specifications defined by the manufacturer for bodies, the Converter must demonstrate compliance with the exhaust gas emissions requirements/electric range.

Information about the ISC parameters*/maximum technical specifications* for bodies can be found on the Volkswagen Customised Solution Portal. Please ask your technical service/test centre for advice if you have questions about alternatives.

To determine the consumption values of converted new vehicles in compliance with the WLTP procedure and to obtain a WLTP certification, the “WLTP Conversion Calculator” is available to you.

You can find more information as a Registered Converter on the Customised Solution Portal / WLTP:

Germany/International: <https://www.customized-solution.com>

1.2.1.9 Manufacturer’s declaration

We issue a manufacturer's declaration for the basic vehicle for the following scopes:

- Load increases and reductions
- Electromagnetic compatibility (EMC)

Please contact our customer support:

nutzfahrzeuge@volkswagen.de

1.2.2 Converter guidelines, consulting

The Converter guidelines define the technical requirements for Converters and equipment fitters designing and mounting bodies for base vehicles of the Volkswagen Commercial Vehicles brand. The Converter guidelines must be strictly adhered to when performing any modifications to the vehicle. Ensure that no modification adversely affects the functional reliability and safety of the running gear, the body or the electric system. Modifications must only be performed by qualified specialists and in accordance with the generally acknowledged rules of the automotive industry.

Prerequisites for modifications to used vehicles:

- The vehicle shall be in a good overall condition, i.e. structural parts such as longitudinal and cross members, pillars etc. shall not be corroded to such an extent that structural stability might be adversely affected
- Vehicles whose modifications might affect the validity of the general certificate of roadworthiness must be presented to an authorised testing centre for approval. It is recommended to clarify in advance with the relevant authority whether approval is required

When enquiring about planned modifications, please enclose two sets of design drawings of the complete scope of the modification, including weights, centre of gravity and dimensions, which also clearly show how the body is attached to the chassis. Please use the online contact form for this (see [chapters 1.2.1.1 “Contact in Germany”](#) and [1.2.1.2 “International contact”](#)).

Please also provide information about the intended operating conditions of the vehicle.

The work safety regulations of the trade association and the EU Machinery Directive apply.

When making modifications to vehicles, all corresponding and applicable legal regulations, rules, laws and directives must be observed.

1.2.2.1 Letter of non-objection

Volkswagen AG does not issue body approvals for non-Volkswagen bodies. It merely provides Converters with important information and technical specifications for dealing with the product in these guidelines.

As a result, Volkswagen AG recommends that all work should be carried out on the basic vehicle and the body in accordance with the current Volkswagen Converter guidelines applicable to the vehicle in question.

Volkswagen AG does not recommend body activities that:

- are not conducted according to these Volkswagen Converter guidelines
- exceed the gross vehicle weight rating
- exceed the gross axle weight rating

Volkswagen AG issues letters of non-objection on a voluntary basis, as follows:

- The assessment conducted by Volkswagen AG is exclusively based on the documents submitted by the Converter who is carrying out the modifications. The inspection and safety assessment only relate to the expressly designated scope of work, its basic compatibility with the designated chassis and its interfaces or, in the event of chassis modifications, the fundamental admissibility of the design for the designated chassis

The letter of non-objection relates to the presented whole vehicle, and not:

- To the design of the overall body,
- Its functions or
- The planned use.

Non-objection is only possible if the design, production and assembly are carried out by the Converter performing the modifications in accordance with the current technology and in compliance with the applicable Converter guidelines of Volkswagen AG – and assuming any deviations from these guidelines have been declared to be technically safe. The letter of non-objection does not release the Converter who is performing the modifications from its responsibility for the product, or from its obligation to carry out its own calculations, tests and a trial of the entire vehicle in order to ensure that the operational safety, road safety and driving properties of the overall vehicle it has manufactured are acceptable. Accordingly, it is necessary to ensure that the Converter exclusively accepts its responsibility for ensuring that its body activities are compatible with the basic vehicle as well as the operational and road safety of the vehicle.

It is expressly stated that the letter of non-objection from Volkswagen AG does not represent a technical approval for the investigated changes.

In the course of assessment of a presented vehicle, an assessment report is written as a means of obtaining a letter of non-objection (LONO report).

The following assessment results are possible:

- Classified as “safe”
If the whole vehicle is classified as “safe”, the Sales department can subsequently issue the LONO certificate.
- Classified as “not safe”
Classification as “not safe” in the individual categories:
 - + Basic vehicle configuration
 - + Impairment of the basic vehicle and possibly
 - + Sole body item

leads to a corresponding classification of the whole vehicle. This means no LONO certificate can be issued initially.

In order for a not-safe classification to be resolved, the LONO report states the necessary modification for each item in question. In order for the letter of non-objection to be obtained, these points will have to be addressed by the Converter and documented in a clearly comprehensible manner in a report along the same lines as the LONO report. On the basis of this detailed report, it is possible for the desk-review assessment to be completed with a positive result.

Depending on the defective points, it may be necessary not only to provide documentation of the defect resolution but also for the vehicle from the first inspection to be presented again. The first report indicates if it will be necessary for a new assessment to be carried out on the vehicle.

The assessment report may also contain “notes/recommendations”.

Notes/recommendations are technical remarks which do not have any effect on the final result of a letter of non-objection. They should be regarded as advice and suggestions for further consideration to support the continuous improvement of the final product for the customer.

In addition, “notes/recommendations solely relating to the conversion” can also be formulated.

The information and recommendations stated as “solely relating to the body/conversion” must be dealt with and documented before the vehicle can be included in the Customised Solution Portal.

Practical note

Country-specific laws, directives and approval regulations shall be observed!

1.2.2.2 Application for the letter of non-objection

In order for the assessment to be carried out for the letter of non-objection, auditable technical documents and drawings shall be submitted to the department responsible before work begins on the vehicle (see [chapter 1.2. "General notes"](#)).

Speedy handling of the request requires:

- Documents preferably in standardised digital formats (e.g. PDF, DXF, STEP)
- Technical data and documentation should be complete

The following details must be included:

- Vehicle type
 - + Vehicle design
 - + Wheelbase
 - + Frame overhang
- Vehicle identification number (if already available)
- Any deviations from these Converter guidelines must be indicated on all documentation
- Axle load calculation
- All data about dimensions, weight and centre of gravity (weighing certificate)
- Special operating conditions (e.g. poor road conditions, extreme dust, high altitude, or ambient temperature extremes)
- Certificates (e-registration, seat tensile test)
- Attachment of the body on the vehicle
- Type of fixation for the body or add-ons to the vehicle frame (bolting, bonding, welding)
- Photographic documentation of the conversion
- All documents must clearly correlate with the conversion (e.g. drawings marked with allocated numbers)
- General (functional) description of deviations from the production vehicle, or added components
- Electric wiring diagram
- Details of the consumption of additional electrical equipment

Complete documentation avoids the need for clarification queries and accelerates the processing.

1.2.2.3 Legal entitlements

There is no legal entitlement for a letter of non-objection to be issued.

Due to ongoing technical development and the information derived from this, Volkswagen AG is entitled to refuse a letter of non-objection even if a comparable certificate had been issued formerly.

The letter of non-objection can be restricted to individual vehicles.

The subsequent issue of a letter of non-objection may be refused for vehicles that have already been completed or delivered.

The Converter is solely responsible for:

- the function and compatibility of its body activities with the base vehicle
- road safety and operational reliability
- all body activities and installed parts

1.2.3 Warranty and product liability of the Converter

UNECE Regulation No. 155 for vehicle cyber security and UNECE Regulation No. 156 for vehicle software updates apply to all new vehicle types from mid-2022 and to all new vehicle registrations from mid-2024; these contain new requirements for automotive cyber security and updates.

Insofar as modifications are made to the vehicle, the Converter shall also ensure that these regulations are applied and complied with. The Converter's or equipment fitter's warranty conditions apply to the Converter's or equipment fitter's scope of supply. Therefore, warranty claims associated with complaints to this scope of supply cannot be made under the warranty conditions applicable to Volkswagen Commercial Vehicles.

Defects of bodies, installations and equipping provided by third parties as well as defects of the vehicle caused by the said bodies, installations or conversions are excluded from the Volkswagen warranty and also from the Volkswagen paint and body warranty. This also applies to accessories which were not installed and/or supplied by the vehicle manufacturer.

The Converter or equipment fitter is solely responsible for the design and assembly of bodies and the execution of conversions.

All modifications must be documented by the Converter or equipment fitter.

The Converter is responsible for ensuring that all modifications it performs comply with the technical vehicle regulations, specifications and standards that apply in the countries of registration.

Due to the multitude of modifications and diversity of operating conditions, the information provided by Volkswagen AG is subject to the reservation that modified vehicles are not tested by Volkswagen AG. Modifications may affect the properties of the vehicle.

For reasons of liability, the Converters or equipment fitters must provide the following information in writing to their customers:

"Due to the modifications* to your Volkswagen Commercial Vehicles basic vehicle, the properties of your basic vehicle may have changed. Please understand that Volkswagen AG does not assume any liability for any negative effects resulting from the modifications* to the vehicle."

In individual cases, Volkswagen AG reserves the right to demand evidence of the information being passed on to the customer.

No general legal entitlement for the approval of a body modification exists, even if such approval was previously granted.

If bodies comply with the present guidelines, no additional approval by Volkswagen AG is required for the presentation of the vehicle at the relevant authority examining roadworthiness.

* At this point, the term "modification" may be substituted by a more precise description of the work performed, e.g. by "camping equipment installation" or "wheelbase extension".

1.2.4 Ensuring traceability

Body dangers only detected after delivery can mean that subsequent measures in the market will be necessary (customer information, warning, call-back). To make these measures as efficient as possible, it is necessary to be able to trace the product after delivery. For this purpose, and in order to be able to use the central vehicle register (CVR) operated by the Federal Motor Transport Authority or comparable registers abroad in order to trace the affected vehicle owners, we strongly recommend that Converter should store the serial number/identification number of their body linked to the vehicle identification number of the base vehicle in their databases. For this purpose, it is also recommended that customers' addresses are stored and that subsequent owners are provided with a means of registration.

1.2.5 Badges

VW badges and VW emblem are trademarks of Volkswagen AG. VW badges and VW emblems are not allowed to be removed without authorisation, or to be attached in a different location.

1.2.5.1 Positions on rear of the vehicle

VW badges and VW emblems which are enclosed in the delivery must be fitted in the location intended by Volkswagen.

1.2.5.2 Appearance of whole vehicle

If the vehicle does not correspond to the appearance and the quality requirements set by Volkswagen AG, then Volkswagen AG reserves the right to request removal of the Volkswagen AG trademarks.

1.2.5.3 Non-Volkswagen trademarks

Non-Volkswagen badges are not allowed to be attached next to Volkswagen badges.

1.2.6 Recommendation for vehicle storage

Extended storage times cannot always be avoided. The following measures are recommended to ensure that vehicle quality is not affected by long-term storage:

Carry out the following when the vehicle is delivered:

- Check on a weekly basis for aggressive deposits (e.g. bird droppings, industrial deposits) and clean if necessary
- 12-V battery: Determine the SOC* and, if necessary, complete the battery care programme (see the instructions “Carry out no later than every three months”)
- High-voltage battery: Read the state of charge in the instrument cluster
- If the charging indicator is in the red area. This means: $\leq 10\%$ or $< 1/4$ or < 50 km (depending on the display)
- Charge the high-voltage battery until the display shows a maximum of half full
- Set the tyre pressure to 3.4 bar (not the spare wheel)
- Open all front vents in the dash panel, set the blower to maximum and run for one minute
- Remove any paper and other objects from the storage compartments and surfaces in the vehicle interior (dash panel, seats, luggage space) except for items that serve to protect the surfaces
- If fitted, roll in the luggage compartment cover and the sun blinds
- In addition, for new vehicles: Correct the position of the transport protective hoods if necessary
- Record the date of delivery as a reference for all vehicle care measures

*State of Charge

Carry out after no longer than six weeks:

- For vehicles stored without a solar panel:
- Battery care programme (see “Carry out after no longer than three months”)
- Do not disconnect the battery to do so!

Carry out after no longer than three months:

- Remove rust from brake disc
- When storing vehicles without solar panels: complete the battery care programme
- Do not disconnect the battery to do so!
- No battery status display in the dash panel insert:
- Measure the open-circuit voltage of the 12 V battery two hours after the last electrical equipment was active
- a) At an open-circuit voltage between 11.6 V and 12.5 V: Fully charge immediately
- b) If the open-circuit voltage is <11.6 V: Mark and fully charge the defective battery
- A maximum charging voltage of 14.8 V must not be exceeded.
- The totally discharged battery must be replaced before the vehicle is handed over to the customer

Practical note

To determine the exact residual capacity of the 12 V battery, please proceed in accordance with the test conditions in the Workshop Manual.

Carry out after no longer than six months:

- For vehicles stored with a solar panel:
- Carry out the battery maintenance programme (see “Carry out after no longer than three months”)
- Do not disconnect the battery!

Information

You can find further information about vehicle storage in the following documents:

- Owner’s Manual
- Vehicle care programme

1.2.7 Compliance with environmental rules and regulations

Environmental note

The following principles of environmentally friendly design and material selection should be followed right from the planning stage of fitted components or bodies, and the statutory requirements in the EG Directive on End-of-Life Vehicles 2000/53/EC should also be taken into account.

The Converter is responsible for ensuring that all modifications it performs comply with the environmental regulations, specifications and standards that apply in the countries of registration and sale. These may go beyond the existing prerequisites of the basic vehicle and are the responsibility of the Converter.

The Converter must ensure that add-ons and bodies (conversions) comply with all applicable environmental rules and regulations, especially, but not only, EU directive 2000/53/EC concerning end-of-life vehicles and the REACH Regulation (EC) 1907/2006 relating to restrictions on the marketing and use of certain dangerous substances and preparations ("low flammability" and certain flame-retardant agents).

The registered keeper must keep all assembly documentation concerning the modification and hand it over together with the vehicle to the dismantler. This ensures that modified vehicles are processed in compliance with environmental rules and regulations at the end of their life cycle.

Materials which represent a potential risk such as halogen additives, heavy metals, asbestos, CFCs and chlorinated hydrocarbons shall be avoided.

Under environmental law, the Converter must also ensure the following aspects. Please note that the following list merely contains examples and is not exhaustive:

- EU Directive 2000/53/EC must be adhered to
- Preferably, materials which allow valuable substance recycling and closed material cycles shall be used
- The material and production process shall be selected so that only low amounts of easily recyclable waste are generated
- Plastics shall only be used where these offer advantages in terms of cost, function or weight
- In the case of plastics, especially composite materials, only mutually compatible substances from one material family may be used
- With regard to components that are relevant for recycling, the number of plastic types used shall be kept as low as possible
- It is necessary to check whether a component can be manufactured from recycled material or with recycled additives
- Care shall be taken to ensure that recyclable components can be removed easily, e.g. by means of snap-lock connections, predetermined breaking points, good accessibility, use of standard tools
- Simple, environmentally friendly removal of the fluids shall be ensured by means of drain plugs etc.
- Wherever possible, the components shall not be painted or coated; instead, dyed plastic parts shall be used
- Components in areas at risk of accident shall be designed to be tolerant of damage, repairable and easy to exchange
- All plastic parts shall be identified according to the VDA material sheet 260 ("Components of motor vehicles; Identification of materials"), e.g. "PP-GF30R"

1.2.8 Recommendations for inspection, maintenance and repair

Maintenance instructions or service schedules outlining inspection and servicing work should be provided for the modifications performed by the Converter or equipment fitter. These instructions or schedules must include the maintenance and inspection intervals as well as the required operating fluids and materials and the spare parts. It is also important to specify parts and components with a limited service life which are to be checked at regular intervals in order to ensure service reliability and timely replacement where required.

This should be supported by a repair manual including tightening torques, settings and tolerances as well as other relevant specifications. Special tools, including their source of supply, must also be stated.

The manual shall also state which type of work has to be performed only by the Converters and accessories fitters or their authorised workshops.

If the Converter's or accessory fitter's scope of supply includes electric, electronic or mechatronic, hydraulic or pneumatic systems, circuit diagrams and diagnosis routines or similar documentation facilitating a systematic search for faults shall be provided.

Please observe the Volkswagen AG owner's manual for the inspection, maintenance and repair of base vehicles. Please only use brake fluids and engine oils approved by Volkswagen for your vehicle.

More information about brake fluids and engine oils can be found in the Owner's Manual of your vehicle:

In addition to the paper version of the owners manual, which you can find in the vehicle, you can obtain the valid owner's manual for your vehicle in electronic form via the following link and the vehicle identification number.

https://userguide.volkswagen.de/public/vin/login/de_DE

1.2.9 Accident prevention

Converters shall ensure that the bodies comply with applicable legal rules and regulations as well as all regulations regarding work safety and accident prevention. All safety rules and the information material provided by accident insurance providers shall be observed.

All technically feasible measures must be taken to prevent unsafe operation. Country-specific laws, directives and approval regulations must be observed. The Converter is responsible for the compliance with these laws, rules and regulations. For further information about commercial freight traffic in the Federal Republic of Germany please contact:

P.O. box address	Berufsgenossenschaft für Fahrzeughaltungen Fachausschuss "Verkehr" Sachgebiet "Fahrzeuge" Ottenser Hauptstrasse 54 D-22765 Hamburg
Telephone	+49 (0) 40 39 80 – 0
Fax	+49 (0) 40 39 80-19 99
Email	info@bgf.de
Home page	http://www.bgf.de/

1.2.10 Quality system

Worldwide competition, increased quality requirements placed on the overall product by customers, national and international product liability legislation, new forms of organisation and increasing pressure on costs are demanding effective quality assurance systems in all areas of the automotive industry.

The requirements of a quality management system of this kind are described in DIN EN ISO 9001.

For the reasons stated above, Volkswagen AG strongly recommends that all Converters should set up and maintain a quality management system with the following minimum requirements:

- Definition of responsibilities and authorisations including organisational plan.
- Description of the processes and procedures
- Appointment of quality management representative
- Performing contract and build feasibility checks
- Performing product checks based on specified instructions
- Regulating the handling of faulty products
- Documentation and archiving of test results
- Ensuring the quality records of employees are up to date
- Systematic monitoring of test equipment
- Systematic material and parts identification
- Performing quality assurance measures at the suppliers
- Ensuring the availability of process, working and test instructions, and that they are up to date, in the departments and in the workplace

1.3 Planning bodies

Practical note

During the planning of bodies, the right choice of materials and thus the observance of corrosion protection measures are important in addition to a user and maintenance friendly design. (See [chapter 2.3.2.10 “Corrosion protection measures”](#)).

1.3.1 Selecting the basic vehicle

The base vehicle needs to be selected carefully to ensure safe usage in the respective field.

When planning, please consider the following for the use in question:

- Wheelbase
- Engine/gearbox
- Approval process
- Gross vehicle weight rating
- Centre of gravity
- Seating version (number and arrangement)
- Electric scopes (e.g. interior lighting, battery, e-interface for special vehicles, customer-specific functional control unit (CFCU*)). See [chapter 2.5 “Electrics/electronics”](#)

Practical note

Before carrying out body building or conversion work, the supplied basic vehicle should be checked with regard to the fulfilment of applicable requirements.

Please choose the appropriate electrical interface for the planned use of the vehicle.

See [chapter 2.5.3 “Electrical interface for special vehicles”](#).

To enable a CFCU to be retrofitted, it is essential to also order the IS9 (preparation interface for external use).

You can find more information on the available body versions from the relevant department (see [chapter 1.2.1 “Product and vehicle information for Converters”](#))

Information

On the Volkswagen AG homepage you can put your vehicle together using the configurator and view the available optional equipment:

<https://www.volkswagen-nutzfahrzeuge.de/de/modelle.html>

1.3.2 Vehicle modifications

Before starting work on the body, the Converter should check whether:

- the vehicle is suitable for the planned body
- the vehicle type and the equipment also correspond to the operating conditions after the conversion
- the type of approval is still valid after the changes (weight change or change to aerodynamics). In this regard, see also [chapter 1.2.1.8 Worldwide Harmonised Light-Duty Vehicles Test Procedure \(WLTP\)](#)
- the technical limits for add-ons are complied with when using Vehicle High (see details in the table below)

Build dimension drawings, product information and technical data can be obtained from the responsible department or via the communication system for the planning of bodies (see [chapters 1.2.1.1 “Contact in Germany”, 1.2.1.2 “International contact”](#) and [1.2.2 “Converter guidelines, consulting”](#)).

Furthermore, the special equipment available from the factory should be noted (see [chapter 1.4 “Special equipment”](#)).

After the modifications have been made, the vehicles must comply with the regulations valid in the countries of registration.

Technical limits for add-ons for vehicle high registration. Further information can be found on the Customised Solution Portal.

Add-ons	Max. external dimensions of add-ons (WxLxH) mm *	Position on the vehicle
Fan on the roof	310x310x135	Any position on the roof
Rotating lights	Max. Ø 160 Max. height 205	Any position on the roof
Cooling system on the roof	775x580x180	Position the roof structure at a suitable location on the vehicle roof or on the railing.
Special signal system on the roof railing or bolted directly onto the roof	1100x415x150	Position the roof structure at a suitable location on the vehicle roof or on the railing.
Roof-mounted turn signals	Max. height 180	Position according to applicable approval regulations
Side fan	50x300x100	Any position on the side panel/sliding door

* B = width (transverse to direction of travel) / L = length (in direction of travel) / H = height (component height)

Information

Please note that a majority of the EC directives announced to date have been annulled by Regulation (EC) 661/2009 “General Safety”. The EC directives have been replaced by new EU directives or UN R regulations with the same corresponding content.

Practical note

Sufficient space must be provided in order to guarantee the function and operating safety of the power units.

Warning note

Do not modify the steering or brake system! Modifications to the steering and brake system can result in these systems no longer working correctly and failing. This may result in the driver losing control of the vehicle and causing an accident.

Practical note

Modifications to the noise encapsulation can have effects which are relevant to registration.

1.3.3 Vehicle acceptance

The officially recognised appraiser or tester from the Converter must be informed about modifications to the vehicle.

Practical note

Country-specific laws, directives and approval regulations shall be observed!

1.4 Special equipment

We recommend using the optional equipment from Volkswagen AG that can be obtained with a PR number for optimum adaptation of the body to the vehicle.

You can obtain information on special equipment provided by Volkswagen under PR numbers from your authorised repairer or in your contact options for product and vehicle information for Converters (see [chapter 1.2.1 “Product and vehicle information for Converters”](#)).

Please also note [chapter 4, “Implementation of special bodies”](#)

Information

You can also put together your vehicle in the configurator on the Volkswagen AG homepage and view the special equipment available:

<https://www.volkswagen-nutzfahrzeuge.de/de/modelle.html>

Retrofitted special equipment (e.g. reinforced springs, frame reinforcements, anti-roll bars etc.) increase the kerb weight of the vehicle (see also [chapter 4 “Implementation of special bodies”](#)).

Practical note

Permanently installed components increase the kerb weight of the vehicle. As a result, the suspension compression height on the rear axle is reduced accordingly. If the additional installation solution weighs more than 180 kg, we recommend converting a specially coordinated spring pack (PR number UC5). See also [chapter 2.2.7.1 “Rear axle running gear for heavy installations”](#).

The actual vehicle weight and the axle loads should be determined by weighing after the body is built.

Not all additional equipment can be installed into every vehicle without problems.

This applies in particular if it is retrofitted.

Warning note

Please bear in mind that if the permanently installed components are removed then the spring pack, PR number UC5, must be replaced by standard equipment. Otherwise, the driving properties might be negatively impaired.

2 Technical data for planning

2.1 Basic vehicle

2.1.1 Vehicle dimensions

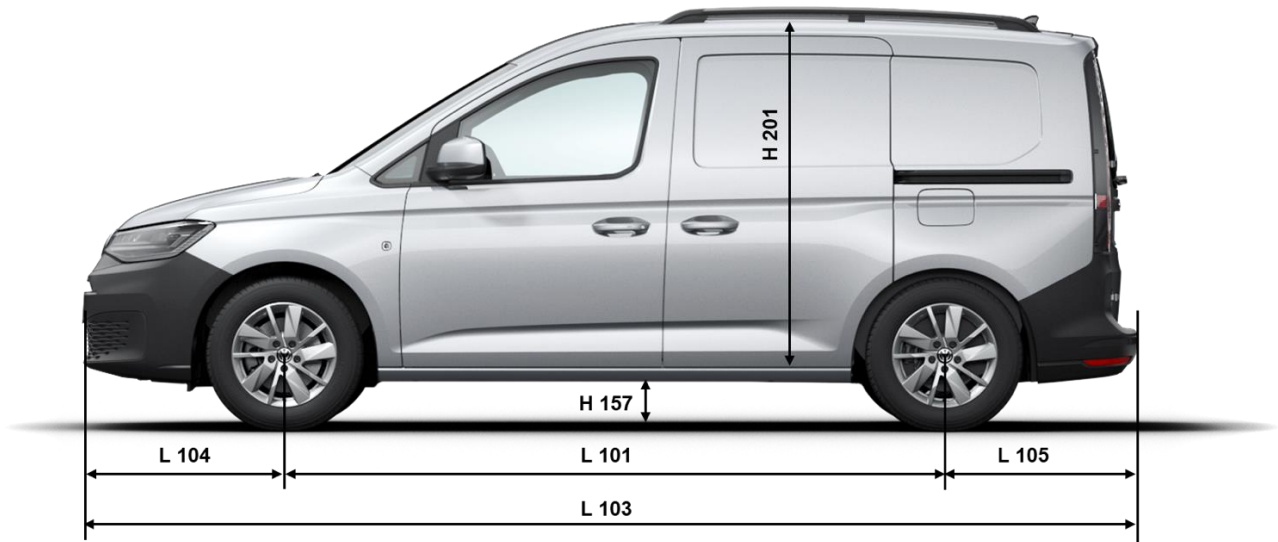

Fig. 1: Vehicle dimensions for Caddy (acc. to DIN 70020, T1)

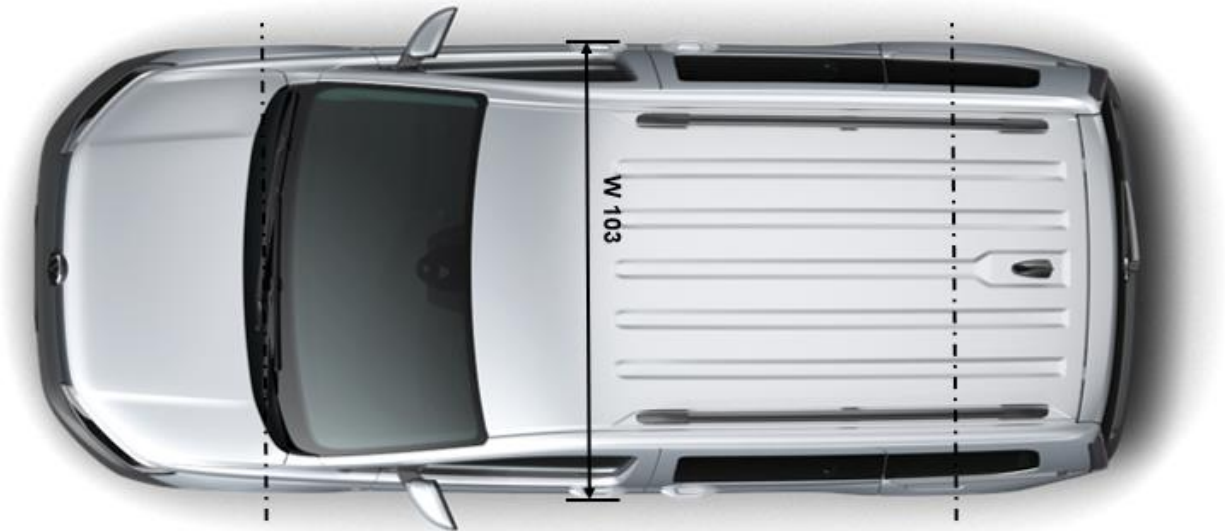

Fig. 2: Vehicle dimensions for Caddy (acc. to DIN 70020, T1)

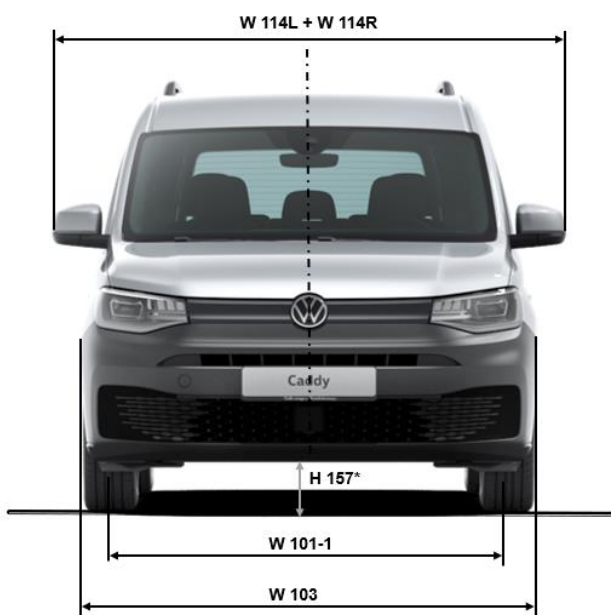

Fig. 3: Vehicle dimensions Caddy/Caddy Maxi, front view (acc. to DIN70020, T1)

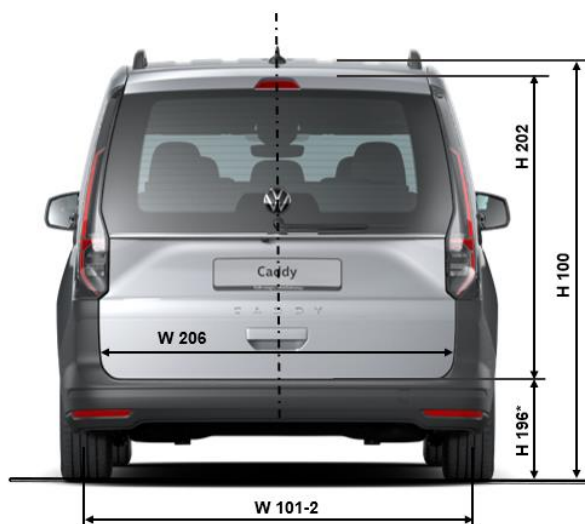

Fig. 4: Vehicle dimensions Caddy/Caddy Maxi, rear view (acc. to DIN70020, T1)

* The vehicle dimensions concerning ground clearance and load bed differ from one another depending on the engine and equipment variant.

2.1.1.1 Basic data of Caddy Cargo

Basic data Caddy (all engines)		Caddy [mm]	Caddy Maxi [mm]	
Dimensions	L101/1	Wheelbase	2,755	2,970
	L103	Vehicle length	4,500	4,853
	L102	Vehicle length with towing bracket (rigid/removable)	4,601	4,954
	L515	Centre of gravity position, load compartment, behind the front axle	2,605	2,781
	L515.1	Centre of gravity position, load compartment, behind the front axle 5-seater	2989	3,165
		Centre of gravity position, load compartment, behind the front axle FlexCab	3,004	3,180
	W103	Vehicle width (measuring point: door handle)	1,855	1,855
	H100-B	Vehicle height of body	1,819	1,823
	H100.2	Vehicle height with aerial base	1,856	1,860
	H100.4	Vehicle height with roof railing	1,853	1,859
	L104	Front overhang length	890	890
	L105	Rear overhang length	855	993
	L105.1	Rear overhang towing bracket	956	1094
	W101.1	Track width at front		
		With wheel offset depth 47	1,569	1,570
With wheel offset depth 48		1,567	1,567	
W101.2	Track width at rear:			
	With wheel offset depth 47	1,606	1,606	
	With wheel offset depth 48	1,604	1,604	
	With wheel offset depth 49	1,603	1,602	

Basic data Caddy (all engines)			Caddy [mm]	Caddy Maxi [mm]
	H157/1* (ML1***)	Ground clearance (engine shield, front)	160	159
		Ground clearance (engine shield, front) CNG	---	156
	H157/1_T* (ML1***)	Ground clearance between axles	180	179
		Ground clearance between axles CNG	---	176
	A116.1	Front ramp angle at full load, limited by spoiler	16.8°	16.6°
		Front ramp angle at full load, limited by spoiler (PHEV)	16.6°	15.4°
		Front ramp angle at full load, limited by spoiler (CNG)	---	16.8°
	A116.2	Rear ramp angle at full load, limited by bumper	18.7°	16.1°
		Rear ramp angle at full load, limited by bumper (PHEV)	19.4°	17.2°
		Rear ramp angle at full load, limited by spoiler (CNG)	---	15.7°
A117	Breakover angle	14.0°	13.0°	
	CNG breakover angle	---	12.7°	
Turning circle	D102	Minimum turning circle	11.4m	12.1 m
Wheels/tyres		Basic tyres**	Smallest tyre 205/60 R16 96 H Largest tyre 225/45 R18 95 H	
Load compartment measurements	L202	Length of load area (EG1230/2012), 2-seater	1,648	2,001
		Length of load area (EC 1230/2012), 5-seater	880	1,233
		Length of the load area (EC 1230/2012), FlexCab	848	1,201
	L301-2	Luggage compartment length 1st row of seats	1,797	2,150
	W200	Largest luggage compartment width (measuring point sliding door)	1,614	1,614
	W201*	Minimum load-through width between the wheel housings	1230	1230
	H201*	Loading height	1,259	1,264
		Load height up to cross strut	1,233	1,239
		Loading height with floor covering	1,256	1,261
		Loading height with floor covering up to cross strut	1230	1,237
	H196*	Load sill height above ground level	586	589
	H508	Clear opening height of sliding door	1096	1096
	L902	Clear opening height – front door / front door 4-door	817	817
	L903	Clear opening width of sliding door	695	836
		Clearance opening width of sliding door (without partition)	703	846
	H202	Body opening height with rear lid	1,130	1,130
Body opening height with wing door		1122	1122	
W206	Largest width of rear opening	1,234	1,234	

Basic data Caddy (all engines)			Caddy [mm]	Caddy Maxi [mm]
Garage dimensions	W120-1	Vehicle width, front doors open	3,689	3,689
	W120-2	Vehicle width, rear doors open	2,128	2,130
	W114-L	Width incl. left exterior mirror	1,050	1,050
	W114-R	Width incl. right exterior mirror	1,050	1,050
Vehicle interior	H61-1	Headroom – 1st seat row	1,129	1,129
	H61-2	Headroom – 2nd seat row	--	--
	H61-3	Headroom – 3rd seat row	--	--

Basic data for Caddy Cargo, version dated June 2024

* The vehicle dimensions concerning ground clearance and load bed can differ from one another depending on the engine and equipment variant.

** The permitted tyre size varies depending on the engine and the gross vehicle weight rating.

**** ML1 = measurement load 1 (unladen vehicle)

2.1.1.2 Basic data of Caddy

Basic data Caddy (all engines)			Caddy [mm]	Caddy Maxi [mm]
Dimensions	L101/3	Wheelbase	2,755	2,970
	L103	Vehicle length	4,500	4,853
	L102	Vehicle length with towing bracket (rigid/removable)	4,601	4,954
	L515	Centre of gravity position, load compartment, behind the front axle – 5-seater	2989	3,165
		Centre of gravity position, load compartment, behind the front axle – 7-seater	3,354	3,550
	W103	Vehicle width (measuring point: door handle)	1,855	1,855
	H100-B	Vehicle height of body and high-level running gear	1,798	1,800
			1,817	1,820
	H100.2	Vehicle height with aerial base and high-level running gear	1,833	1,835
			1,854	1,856
	H100.4	Vehicle height with roof railing and high-level running gear	1832	1,836
			1,851	1,856
	L104	Front overhang length	890	890
	L105	Rear overhang length	855	993
		Rear overhang with towing bracket on ML1	956	1094
	W101-1	Track width at front		
		With wheel offset depth 47	1,572	1,572
With wheel offset depth 47 with high-level running gear		1,569	1,569	
With wheel offset depth 48		1,570	1,570	
With wheel offset depth 48 with high-level running gear		1,567	1,567	
With wheel offset depth 49		1,568	1,568	
W101-2	Track width at rear:			
	With wheel offset depth 47	1,606	1,606	
	With wheel offset depth 47 with high-level running gear	1,606	1,606	
	With wheel offset depth 48	1,604	1,604	
	With wheel offset depth 48 with high-level running gear	1605	1605	

		With wheel offset depth 49	1,603	1,603
		With wheel offset depth 49 with high-level running gear	1,603	-1,603
Basic data Caddy (all engines)			Caddy [mm]	Caddy Maxi [mm]
	H157/1_T* (ML1***)	Ground clearance between axles acc. to 2007/46/EC	153	152
	H157/1_Ta* (ML1***)	Ground clearance between axles acc. to 2007/46/EC with high-level running gear	168	167
	H157/1_Tb* (ML1***)	Ground clearance between axles acc. to 2007/46/EC CNG	---	150
	H157/1* (ML1***)	Ground clearance	144	143
		Ground clearance with high-level running gear	159	158
		Ground clearance CNG	---	141
	A116-1	Front ramp angle at full load, limited by spoiler	14.2°	14.7°
		Front ramp angle at full load, (PHEV)	14.2°	14.0°
		Front ramp angle at full load, high-level running gear	15.3°	15.7°
		Front ramp angle at full load, high-level running gear, (PHEV)	15.0°	14.9°
		Front ramp angle at full load, (CNG)	---	14.2°
	A116-2	Rear ramp angle at full load, limited by bumper	19.3°	15.9°
		Rear ramp angle at full load, (PHEV)	19.8°	16.7°
Rear ramp angle at full load, high-level running gear		21.2°	17.8°	
Rear ramp angle at full load, high-level running gear, (PHEV)		21.7°	18.2°	
Rear ramp angle at full load, (CNG)		---	16.4°	
A117	Breakover angle	12.9°	11.8°	
	Breakover angle high-level running gear	14.7°	13.5°	
	CNG breakover angle	---	11.9	
Turning circle	D102	Minimum turning circle	11.4m	12.1 m
Wheels / tyres		Basic tyres**	Smallest tyre 205/60 R16 96 H Largest tyre 225/45 R18 95 H	
Load compartment measurements	L202	Length of load area (EC 1230/2012), 5-seater	880	1,233
		Length of load area (EG1230/2012), 7-seater	150	463
	L212-0	Luggage compartment length, front passenger seat folded, 2nd seat row folded, 3rd seat row removed	2,732	3,042
		Luggage compartment length, front passenger seat, 2nd seat row and 3rd seat row folded	2,620	2,973
	L212-1	Luggage compartment length, 2nd seat row folded and 3rd seat row removed	1,780	2,136
		Luggage compartment length, 2nd seat row and 3rd seat row folded	1,779	2,135
		Luggage compartment length, without seats in vehicle interior, measured on floor	1,913	2,265
L212-2	Luggage compartment floor length, 2nd row of seats	1,100	1,452	
L212-3	Luggage compartment length, 3rd row of seats	317	629	

	W200*	Largest luggage compartment width (behind 3rd seat row)	1,185	1,185
	W202*	Width between wheel housings	1,185	1,185
	H201*	Loading height	1,200	1,211
		Load height of roof ventilator moulded headliner	1,185	1,211
	H196*	Load sill height above ground level	562	563
		Load sill height above ground level with raised running gear	584	585
	L902	Clear opening height – front door (2-door and 4-door)	817	817
	H508	Clear opening height of sliding door	1,072	1,072
	L903	Clear opening width of sliding door	701	844
	H202*	Body opening height with rear lid	1122	1122
Body opening height with wing door		1,098	1,098	
W206	Largest width of rear opening	1,185	1,185	
Garage dimensions	W120-1	Vehicle width, front doors open (2-door and 4-door)	3,689	3,689
	W120-2	Vehicle width, rear doors open	2,128	2,130
	W114-L	Width incl. left exterior mirror	1,050	1,050
	W114-R	Width incl. right exterior mirror	1,050	1,050
Vehicle interior dimensions	H61-1	Effective headroom – 1st seat row	1,129	1,129
	H61-2	Effective headroom – 2nd seat row (standard)	1,103	1,107
	H61-3	Effective headroom – 3rd seat row (standard)	952	976

Basic data for Caddy, version dated 2024

* The vehicle dimensions concerning ground clearance and load bed differ from one another depending on the engine and equipment variant.

** The permitted tyre size varies depending on the engine and the gross vehicle weight rating.

**** ML1 = measurement load 1 (unladen vehicle)

Information

For additional technical data, especially dimensional drawings and weight information on the Caddy / Caddy Maxi according to the engine and equipment variant, please search online.

2.1.2 Ramp angle and breakover angle



Fig. 1: Overhang and breakover angles, Caddy Caddy Cargo



Fig. 2: Overhang and breakover angles, Caddy

Please refer to the basic data tables for the values of the front and rear overhang angles (A116-1, A116-2) as well as the breakover angle (A-117) in the basic data tables (see [chapters 2.1.1.1](#) and [2.1.1.2](#)).

* The values for the overhang angle A116 may differ for petrol and diesel engines due to different exhaust systems.

2.1.3 Vehicle centre of gravity



Model	L* [mm]	h* [mm]	SV* [mm]	SR* [mm]	SL* [mm]
Caddy Cargo	2,759	617	1,122	801	779
Caddy Maxi Cargo	2,970	633	1,209	799	783

* Position of centre of gravity measured on the vehicle without load rating and with driver

*** Not available by the editorial deadline.

2.1.4 Bodies with a high centre of gravity

The driving properties of vehicles with a high body or with an elevated overall centre of gravity can be expected to be restricted (see also [chapter 2.2.6 "Brake system and brake control system ESC"](#)).

2.1.5 Determining the centre of gravity

Volkswagen recommends having the centre of gravity determined by a recognised test institution with experience in this field (e.g., DEKRA, TÜV or others).

For the Converter to determine the centre of gravity, we recommend following the procedures described in [chapter 6.1 “Determining the centre of gravity”](#).

2.1.6 Steerability – minimum front axle load

In all load situations, the front axle load must correspond to at least 38% of the actual gross vehicle weight. The permitted axle loads must be observed in all load situations.

Please also comply with the following chapters:

- [Chapter 2.2.1 “Permitted weights and unladen weights”](#)
- [Chapter 2.2.6 “Brake system and brake control system ESC”](#)

2.2 Running gear

2.2.1 Permitted weights and kerb weights

Warning note

ATTENTION! The specified maximum gross axle weight ratings must be observed for conversions which result in an increase in the base vehicle's axle weight (e.g. with add-on loads). If these values are exceeded, the durability of all components (and in particular the wheel hubs) must be checked and safeguarded using suitable measures.

Information

Load ratings depend on the engine. Equipment features can influence the payload or load weight by increasing/reducing the unladen weight. The weights specified in the technical data of the sales documents (see [chapter 7](#)) refer to the standard basic vehicle equipment. Weight tolerances of +5% in production are permitted in accordance with DIN 70020 and must be taken into account if necessary.

Installing special equipment reduces the payload.

The actual payload of a vehicle that is calculated from the difference between the gross vehicle weight rating and kerb weight can only be determined by weighing an individual vehicle.

Warning note

The weight data relates to the minimum kerb weight, with driver. Ordering standard and special equipment increases the kerb weight and reduces the load rating. The actual kerb weight should be established by weighing.

If the gross axle weight ratings are exceeded, the ESC system in vehicles with ESC will no longer be able to function correctly.

Furthermore, the overload can lead to damage to load bearing parts and to the running gear. This may result in the driver losing control of the vehicle and causing an accident.

Practical note

For permanent installations, the running gear must be adjusted afterwards. Otherwise, there can be premature, uneven wear on the front axle tyres.

Once the customer has loaded the vehicle to a normal load level for its purposes, the running gear must be measured again in accordance with the workshop manual, based on the current height of the edge of the wheel housing.

You can find further information, such as on the chassis, in the repair and workshop information from Volkswagen AG **erWin*** (Electronic Repair and Workshop Information from Volkswagen AG)

→ Chassis, axles, steering (chapter 44 Wheels, tyres, vehicle measurement, 3-axle measuring):

<http://erwin.volkswagen.de/erwin/showHome.do>

*Information system from Volkswagen AG, subject to payment

2.2.1.1 One-sided weight distribution**Warning note**

The following weights shall not be exceeded under any circumstances:

- Gross vehicle weight rating
- Gross front axle weight rating
- Gross rear axle weight rating

(see chapter 2.2.1 “Permitted weights and kerb weights”).

When planning bodies/additions, make sure that one-sided weight distribution is avoided – in particular involving permanently secured add-ons. The maximum permissible wheel loads and tyre load ratings must be observed.

The front axle load is not allowed to be less than the minimum permitted load in order to ensure adequate steerability of the vehicle and satisfactory driving behaviour under all loading conditions.

(see chapter 2.1.6 “Steerability – minimum front axle load”)

2.2.2 Turning circle

See chapter 2.1.1 “Vehicle dimensions”.

2.2.3 Approved tyre sizes

The Volkswagen Owner’s Manual provides information about the wheel/tyre combinations authorised by Volkswagen AG in conjunction with snow chains (for tyre sizes see also chapter 2.1.1 “Vehicle dimensions”).

2.2.4 Modifications to axles

Modifications to the axles are not permitted, because they can lead to an impairment in the vehicle handling and unstable vehicle handling.

2.2.5 Modifications to the steering system

Modifications to the steering system are not permitted.

For exceptions such as conversions to motor vehicles for conveying mobility-challenged people, contact us before starting a conversion (see [chapter 1.2.1 “Product and vehicle information for Converters”](#)).

2.2.6 Brake system and brake control system ESC*

2.2.6.1 General information

Modifications to the brake system are not allowed under any circumstances:

- If the modification to the brake system goes beyond the scope of the operating permit.
- If the air inflow and outflow to and from disc brakes are modified.

Exceptions shall be approved by Volkswagen AG prior to the conversion, and shall be documented with an independent brake approval report.

Please contact us before starting your conversion (see [chapter 1.2.1, “Product and vehicle information for Converters”](#))

Warning note

Work performed improperly on brake hoses, lines and cables can impair their function.

This can lead to a failure of components or safety-relevant parts. Therefore, work on brake hoses, lines and cables should only be performed by a qualified specialist workshop.

Information

Since 1 January 1991, all commercial vehicles have had to comply with the “EC Brake Systems Directive 71/320 EEC”. When this EC Directive was adopted into national legislation (e.g. the Road Traffic Regulations (StVZO) in Germany), the effect was that these technical regulations also had to be complied with for individual acceptance.

*Electronic Stability Control

2.2.6.2 Vehicle stability and ESC*

As part of the acceptance of the assembled vehicle, the height of the centre of gravity of a loaded vehicle must be determined for verification in accordance with UN -R 13 (brake system).

Refer to [chapter 2.1.3 “Vehicle centre of gravity”](#) for the permitted centre of gravity heights.

Volkswagen does not make any statement about:

- Driving behaviour
- Braking behaviour
- Steering response and
- ESC control response

in bodies for loads with an unfavourably positioned centre of gravity (e.g. rear, high and side loads), because these aspects are significantly influenced by body activities and consequently can only be assessed by the Converter.

Warning note

For both for conversions and installations, as well as in ready-to-drive condition, the gross wheel and axle weight ratings as well as the gross vehicle weight ratings (see [chapter 2.2.1, “Permitted weights and empty weights”](#)) of the vehicle are not allowed to be exceeded under any circumstances. If the gross axle weight ratings are exceeded, the ESC system in vehicles with ESC will no longer be able to function correctly. This may result in the driver losing control of the vehicle and causing an accident.

Practical note

From November 2014, ESC will be a requirement for new vehicles registered in Europe. Vehicles can be exempted from this obligation in special, exceptional cases. Please check whether ESC* is required in the intended country of registration for the envisaged type of the completed vehicle.

*Electronic Stability Control

2.2.6.3 Influence of vehicle conversions on the function of ESC* brake regulation system

ESC – subsystems	Modification on the vehicle				
	Wheelbase modification	Extreme centre of gravity increase	Modification of running gear (springs, dampers, anti-roll bars, wheels, tyres, track, steering)	Different rolling circumferences on individual axles	Modification to the brake (callipers, pads, design)
ABS Anti-lock brake system	+	+	+	++ ³	++
BAS Brake assist system	--	--	+	++ ³	++
EDL Electronic differential lock	+	+	+	++ ³	+++
Hill Start Assist	--	--	-	++ ³	++
TCS traction control system	++	+	+	++ ³	+
ESC Electronic Stability Control	++	++++ ¹	+++ ¹	+++ ³	+++ ¹
Vehicle and trailer stabilisation	++	++	++	++++	+++

1 – In particular, a significantly increased risk of tipping over

2 – Downgrading required

3 – Hardware adaptation of the wheel speed sensors required

-- No effect

- Very little effect

+ Noticeable effect

++ Significant effect

+++ Very significant effect

++++ No technical solution

Warning note

Vehicles with add-ons, bodies, installed components or conversions in which the limit values of the specific vehicle (position of centre of gravity, axle loads, overhangs etc.) are not complied with are regarded as problematical and can have an adverse effect on driving behaviour. Therefore, they should not be operated.

*Electronic Stability Control

Exceptions shall be approved by Volkswagen AG prior to the conversion, and shall be documented with an independent brake approval report. Please contact us before starting your conversion (see [chapter 1.2.1, "Product and vehicle information for Converters"](#)).

2.2.6.4 Routing additional lines along the brake hoses/brake lines

No other additional lines are allowed to be fastened to brake hoses and brake lines.

Additional lines must remain at a sufficient distance from brake hoses and brake lines under all operating conditions, and are not allowed to touch or chafe against such brake hoses/lines under any circumstances.

(see also [chapter 2.5.2.1 Electrical wiring/fuses](#))

2.2.7 Modification of springs, suspension mounting, dampers

The spring rates are never allowed to be modified.

We recommend using optimally matching springs from the Volkswagen delivery range for the vehicle with body.

Modifications to the springs must be assessed by a test centre/monitoring organisation/technical service responsible for this function, and can result in invalidation of the operating permit.

2.2.7.1 Rear axle running gear for heavy installations (retrofit kit, PR number UC5)

The alternative coil springs (optional PR number UC5) for the rear axle compensate the static suspension in the event of heavy installations such as workshop facilities.

The additional components (two coil springs) are included as an accessory pack in the box for retrofitting.

To install the alternative springs (UC5), it is essential that the vehicle is equipped with PR number UC7 (raised running gear). After installation of the additional springs ordered with PR no. UC5, the vehicle has a higher ride height at the rear axle. The ride height is partially reduced again by the installation of stationary fixtures in the load compartment and by the payload.

After installing UC5, the vehicle is higher in the springs because the maximum rear axle load is not utilized. Please note that a towing bracket with a shorter ball coupling is required. If a preparation for towing brackets is ordered ex works, a towing bracket with a shorter ball coupling must be ordered from After Sales in order to comply with the approval regulations.

As this is a safety-relevant conversion/retrofitting, a manufacturer's declaration is required for technical acceptance.

You can obtain this manufacturer's declaration, specifying the vehicle identification number, from:

Nutzfahrzeuge@volkswagen.de

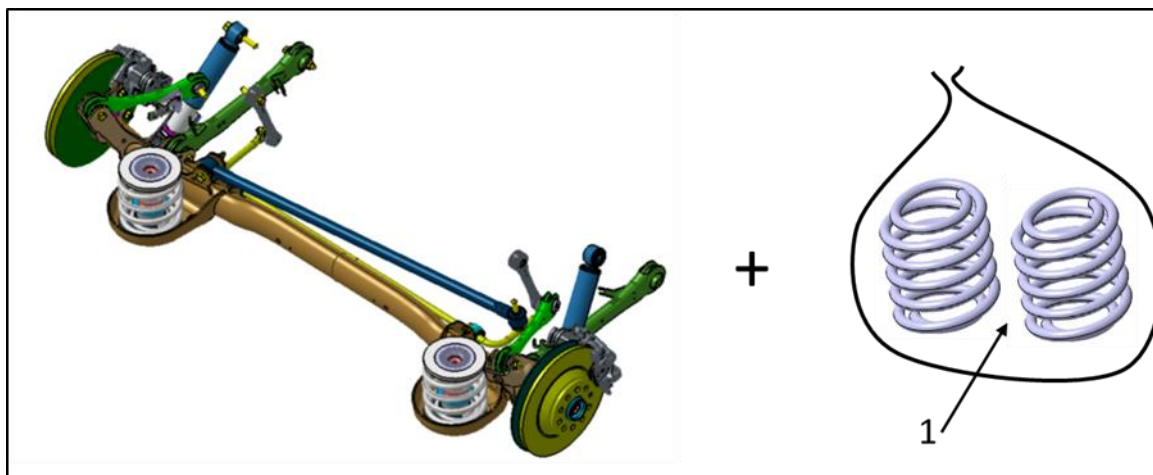

Fig. 1: Rear axle running gear + accessories pack

1 – Body springs as accessory pack

Practical note

A “minimum payload” (e.g. workshop equipment) of 180 kg applies to the rear axle.

The maximum rear-axle empty load of the base vehicle is 730 kg.

Warning note

Please bear in mind that if the permanently installed components are removed then the spring pack, PR number UC5, must be replaced by standard equipment. Otherwise, the driving properties might be negatively impaired.

2.2.8 Wheel alignment settings

Changes to wheel alignment parameters are not permitted!

2.3 Body-in-white

2.3.1 Roof loads/vehicle roof



Fig. 1: Roof load

2.3.1.1 Dynamic roof loads

Vehicle type	Max. roof load
Caddy	100 kg
Caddy Maxi	100 kg

Risk of accident

Please note that roof loads raise the centre of gravity of the vehicle and lead to a high dynamic axle load shift. Also, there is greater body lean when driving on rough roads and when cornering.

The driving characteristics are significantly impaired by this.

Please also comply with chapters:

- [2.1.4 “Bodies with a high centre of gravity”](#)
- [2.2.6.2 “Vehicle stability and ESC”](#)
- [2.2.6.3 “Influence of vehicle conversions”](#)

2.3.2 Modifications to the body-in-white

Changes to the body are not allowed to impair the function and strength of power units and operating devices of the vehicle, neither may they reduce the strength of weight-bearing parts.

During vehicle conversions and assembly of bodies, it is not permitted to make any modifications which impair the function and freedom of movement of the suspension (e.g. for maintenance and inspection work) or the accessibility to the same.

2.3.2.1 Bolted connections

If series-production bolts/nuts have to be renewed, it is only permitted for bolts/nuts to be fitted which have the:

- Same diameter
- Same strength
- Same bolt standard or bolt type
- Same surface coating (corrosion protection, coefficient of friction)
- Same thread pitch

VDI/VDE 2862 sheet 1 (2012-04) must be observed for all installations.

Shortening the free clamping length, changeover to waisted shank and use of bolts with a shorter free thread proportion are not permitted.

Furthermore, take the settling behaviour of bolted connections into account.

Components that are additionally clamped as well shall have the same or a higher strength than the previous clamped combination.

When attaching components to the base vehicle using screws, make sure that no panels or other components of the base vehicle are bent or damaged.

The use of Volkswagen tightening torques assumes that the total coefficient of friction is in the range $\mu_{\text{tot}} = 0.08$ to 0.14 for the particular items being bolted together.

If bolts are tightened by torque and final tightening angle at Volkswagen, no change of design is possible.

Risk of accident

No safety-relevant bolted connections, e.g. for wheel guidance, steering and brake functions, may be modified. Otherwise the designated function may be impaired. This may result in the driver losing control of the vehicle and causing an accident. The new installation is to be carried out according to the instructions of VW Customer Service, using suitable standard parts. We recommend the use of Volkswagen genuine parts.

Information

Information about Volkswagen customer service instructions can be provided by any Volkswagen Customer Service.

2.3.2.2 Welding work

Incorrectly undertaken welding work can lead to a failure of safety-relevant components, and thus cause accidents. Therefore, the following safety measures must be complied with when welding work is performed:

- Welding work should only be undertaken by people with appropriate qualifications
- Before starting welding work, it is necessary to remove components which might contain gases posing a fire or explosion hazard, e.g. fuel system, or else to protect them with a fireproof cover against airborne sparks. Gas containers which could be damaged by airborne sparks during welding work must be removed
- Before welding work starts in the area of seat belts, airbag sensors or the airbag control unit, the components must be removed for the duration of the work. For important information on handling, transporting and storing airbag units, see [chapter 2.4. "Interior"](#)
- Before starting welding work, cover the springs and spring bellows to protect them against welding beads. Springs are not allowed to be touched with welding electrodes or welding tongs
- No welding is allowed on mechanical units such as the engine, gearbox, axles
- Remove and cover the battery positive and negative terminal clamps
- Connect the earth clamp of the welding machine directly to the part to be welded. The earth clamp is not allowed to be connected to power units such as the engine, gearbox, axles
- The housings of electronic components (e.g. control units) and electrical wiring are not allowed to be touched with the welding electrode or earth clamp of the welding machine
- The electrodes are only allowed to be used with direct current via the positive terminal for welding. Always weld from bottom towards the top

Warning note

Welding in the area of the restraint systems (airbag or belts) can lead to these systems ceasing to function properly.

Welding in the area of child restraint systems is therefore prohibited.

Practical note

Disconnect the battery prior to starting welding work.

Airbags, seatbelts, the airbag control unit and airbag sensors shall be protected against weld spatter, and removed if necessary.

2.3.2.3 Welded connections

In order to achieve high-quality weld seams, the following basic recommendations are given:

- Thoroughly clean the areas to be welded
- Apply several short weld beads, rather than one long one
- Make symmetrical beads, in order to limit shrinkage
- Avoid making more than three welds at any one point
- Avoid welding in work-hardened areas
- Spot welds and stitch welding should be offset

2.3.2.4 Selection of welding process

The mechanical properties of weld seams depend on which welding process is selected, and on the geometry of the parts to be connected. If welding overlapping metal panels, the welding process depends on the accessibility of the sides:

Accessible sides	Welding process
1	Shielding gas plug welding
2	Resistance spot welding

2.3.2.5 Resistance spot welding

Resistance spot welding is used for overlapping parts with access on both sides. Avoid spot welding of more than two layers of metal panels.

Distance between spot welds:

In order to avoid shunt effects, the specified distances between the spot welds must be maintained ($d = 10e + 10 \text{ mm}$).

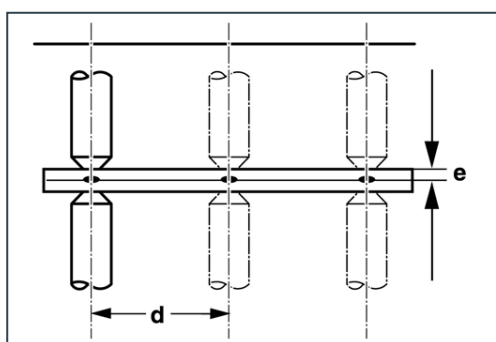

Ratio between panel thickness and distance between spot welds

d – Distance between spot welds

e – Panel thickness

Distance from the edge of the panel:

In order to avoid damage to the molten core, the specified distances from the edge of the panel must be maintained ($L = 3e + 2 \text{ mm}$).

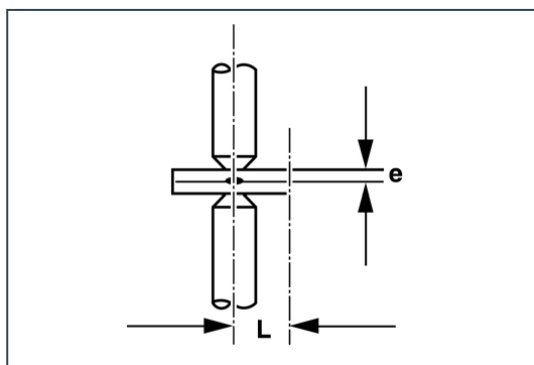

Ratio between panel thickness and distance from edge

e – Panel thickness

L – Distance from the edge of the panel

2.3.2.6 Shielding gas plug welding

If overlapping panels can only be welded on one side, it is possible to achieve the connection by shielding gas plug welding or tacking. If the connection is achieved by punching or drilling and then spot welding the hole, the drilling area must be deburred before welding is carried out.

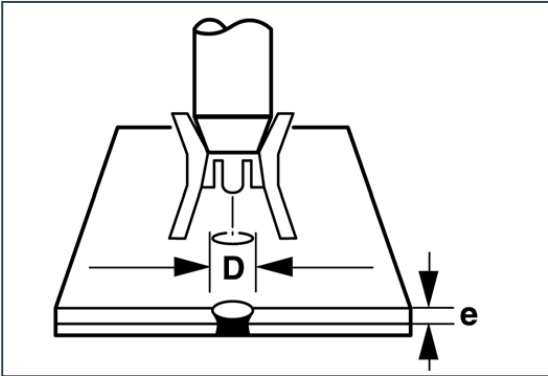

Ratio between panel thickness and hole diameter

D – hole diameter [mm]	4.5	5	5.5	6	6.5	7
E – panel thickness [mm]	0.6	0.7	1	1.25	1.5	2

The mechanical quality can additionally be improved by using “elongated holes” ($l = 2 \times b$).

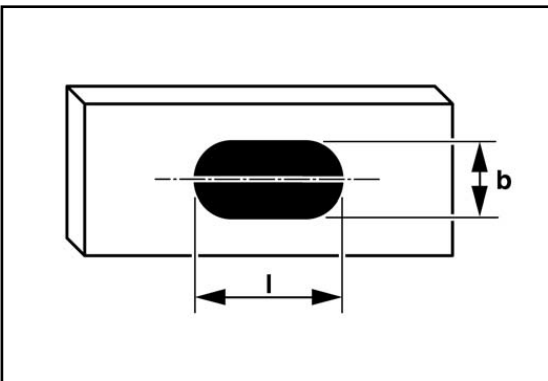

Ratio between width and length of elongated holes

b – Width of elongated hole

l – Length of elongated hole

2.3.2.7 Tacking

If panels are >2 mm thick, overlapping panels can also be connected by tacking
($30 \text{ mm} < L < 40 \times e$; $d > 2 L$).

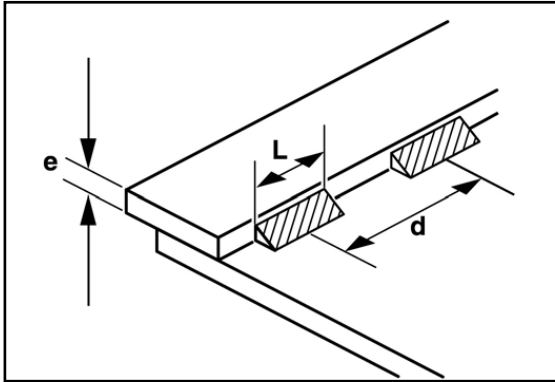

Ratio between panel thickness and distance between welds

d – Distance between tack welds

e – Panel thickness

L – Length of tack welding

2.3.2.8 Welding is not allowed

Welding is not allowed:

- On mechanical units such as the engine, gearbox, axles etc.
- On the chassis frame except if there is a frame extension
- On the A and B-pillars
- On the upper and lower chords of the frame
- In bend radii
- In the area of airbags
- Hole welding is only permitted in the vertical webs of the frame longitudinal member

2.3.2.9 Corrosion protection after welding

After all welding work on the vehicle, it is necessary to comply with the specified corrosion protection measures (see [chapter 2.3.2.10 "Corrosion protection measures"](#)).

2.3.2.10 Corrosion protection measures

Following conversion and installation work on the vehicle, surface and corrosion protection shall be applied to the affected points.

Practical note

Only the corrosion protection agents tested and approved by Volkswagen are allowed to be used for all corrosion protection measures.

2.3.2.11 Planning measures

Corrosion protection should be taken into account in the planning and design in the form of a suitable material selection and component design.

Information

If two different metallic materials are connected together by an electrolyte (e.g. moisture from the air) then this will give rise to a galvanic connection. The result will be electrochemical corrosion, and the less noble metal will suffer damage.

The further apart the metals in question are in the electrochemical series, the greater will be the electrochemical corrosion.

Therefore, the components must have a suitable treatment or insulation applied to them in order to prevent electrochemical corrosion, or the corrosion must be kept at a low level by a suitable choice of materials.

Avoidance of contact corrosion by electrical insulation

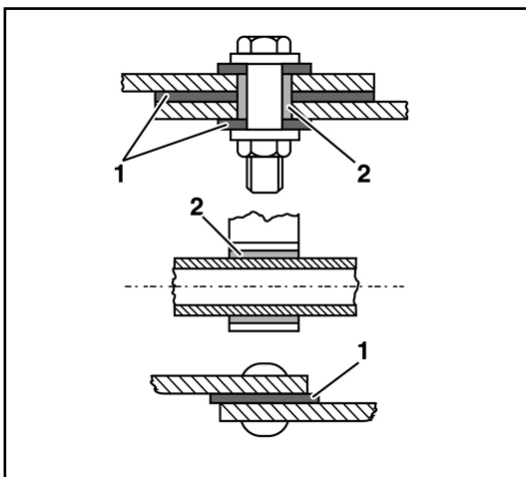

Avoidance of contact corrosion

1 – Insulating washer

2 – Insulating sleeve

Contact corrosion can be avoided by using electrical insulation such as washers, sleeves or tubes. Avoid welding work on inaccessible cavities.

2.3.2.12 Component design measures

Design measures, in particular in the design of connections between the same or different materials, can be used for providing corrosion protection:

- Corners, edges, beads and folds represent locations where dirt and moisture can collect
- Suitable surfaces, drains and the avoidance of gaps at component connections represent means by which corrosion can be counteracted by design measures

Gaps at welded connections as a feature of the design, and how to avoid them:

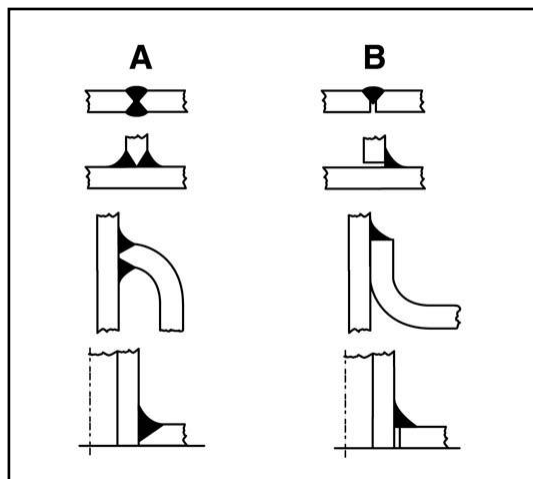

Application examples of welded connections

A = Favourable	B = Unfavourable
(through-welded)	(gap)

2.3.2.13 Coating measures

It is possible to protect the vehicle against corrosion (see [chapter 2.3.2.10 "Corrosion protection measures"](#)) by applying protective coatings (e.g. galvanising, painting or high-temperature zinc application).

2.3.2.14 Work on the vehicle

After all work on the vehicle:

- Remove drilling chips
- Deburr edges
- Remove scorched paint and thoroughly prepare the surfaces for painting
- Apply a primer to all bare metal parts, and paint them
- Apply a wax-based corrosion protection agent to cavities
- Carry out corrosion protection measures on the underbody and frame components

2.4 Interior

2.4.1 Modifications in the area of airbags

Modifications to the airbag system and the belt tensioner system as well as to airbag components, the airbag sensors and the airbag control unit or in their vicinity are not permitted.

Please also refer to [chapter 4.1 “Vehicles for conveying persons with restricted mobility”](#).

The interior fittings shall be designed so that the airbag deployment areas are left unobstructed (see also [chapter 3.2 “Interior”](#)). For information about the deployment zones of the airbags, refer to the Owner’s Manual of the vehicle.

Modifications in the cockpit area and above the seat reference line shall be conducted in accordance with the criteria of the head impact tests acc. to

UN-R 21.

Warning note

Modifications or incorrectly performed work on seatbelts and seatbelt anchor points, belt tensioners or airbags or their cabling could impair the correct function of these components. They might be activated inadvertently or fail in the event of an accident.

2.4.2 Modifications in the area of seats

- If the current load compartment does not have standard anchors for seats and seat belts already installed, then retrofitting, and therefore equipping the load compartment with original Volkswagen seats or rows of seats is not possible
- When original Volkswagen seats are retrofitted, (side) airbags, belt tensioners, seat-occupied recognition system, and belt fastening detection, must all be re-coded by the customer service workshop
- The strength data for seats available ex-works is only valid in conjunction with the original attachment elements
- It is essential not to exceed the height of the centre of gravity (H-point) when retrofitting seats. (See also [chapter 3.2.3 “Seat retrofitting/seats”](#))
- When the seat belts and seats (including seat box) are re-fitted, the prescribed bolts shall be used and tightened to the prescribed torque
- When installing seat belts and belt locks, only Volkswagen genuine parts must be used

Warning note

Only fit seat covers or protective covers that are expressly approved for use in the vehicle.
The use of non-approved covers may prevent the side airbag from deploying.

Warning note

The attachment of seats to the wheel housing is not permitted. This also applies to wheel housings that are lowered. Otherwise damage could be caused to the vehicle (e.g. wheel housing and tyres) and accidents could result.

Information

You will find detailed information, including information on torques, in the Workshop Manuals.

Volkswagen AG Workshop Manuals and workshop information can be downloaded from the internet at **erWin*** (electronic repair and Workshop information from Volkswagen AG):

<http://erwin.volkswagen.de/erwin/showHome.do>

*Information system from Volkswagen AG, subject to payment

2.4.2.1 Belt anchors

The Converter is solely responsible for fitting additional belt points.

The necessary proof is to be provided by the Converter.

The legal specifications and guidelines must be observed, e.g. UN-R 16.

Vehicles in the M and N classes must be equipped with seat belts that comply with the requirements of UN-R 16. The seat belt anchorages must be tested according to UN-R 14.

2.4.3 Forced ventilation vent

A sufficient exchange of air between the driver's compartment and load compartment must be ensured in closed bodies with a retrofitted partition or cab rear wall. If necessary, openings that comply with the cross-section of the standard equipment must be inserted in the partition / cab rear wall. In closed bodies, the existing outlet vents may only be closed by modifications if new outlets are created, e.g. in the cab doors.

This is important in several respects:

- Closing comfort of the doors
- Possible flow rate of the heating blower
- Pressure equalisation on airbag deployment

Air inlets and outlets are not allowed to be fitted in the immediate vicinity of sources of noise or exhaust gases.

2.4.4 Acoustic insulation

Pay attention to minimising interior noise levels as part of conversions, in order to avoid modifying the noise level of the vehicle.

The converted vehicle must comply with the values for external noise given in EC Directive 70/157/EEC.

Specialists such as the manufacturer and suppliers of acoustic material should be contacted for advice on achieving the optimum acoustic protection for bodies.

2.5 Electrics/electronics

General notes:

- Electrical and electronic components shall fulfil the test requirements in accordance with ISO 16750.
- Cables that are laid near to exhaust systems require sleeves that are resistant to high temperatures
- Cables must be routed so that there are no areas of abrasion.
- The batteries shall be disconnected if the vehicle is left standing for longer periods (>20 days). When re-commissioning the vehicle, make sure that the batteries are charged sufficiently.
- The owner's manual must be observed (see [chapter 1.2.1.5 "Online Owner's Manual"](#)).

Warning note

Incorrect interventions in electronic components and their software may result in these no longer functioning as intended. Due to the networking of electronics, systems that were not modified can be affected.

Malfunctions to the electronics can significantly impair the operational safety of your vehicle.

Have work on or modifications to electronic components performed by a qualified specialist workshop which has the necessary specialist knowledge and tools for performing the necessary work.

Volkswagen recommends Volkswagen customer services for this purpose. Service by a qualified specialist workshop is essential, in particular for work on safety-relevant systems.

Some safety systems only operate when the engine is running. Therefore, do not switch the engine off when driving.

Practical note

If additional electrical equipment is installed, a positive overall charging balance must be ensured (see [chapter 2.5.2.3 "Retrofitting electrical devices"](#)).

2.5.1 Lighting

2.5.1.1 Vehicle lighting systems

Comply with the country-specific registration provisions with regard to the complete lighting systems (lighting and turn signal systems).

Note the basic setting for the headlight (see vehicle wallet).

Practical note

The basic setting for the headlight must be observed and, if applicable, adapted to the new construction status (e.g. fixed installations or add-on parts or changes to running gear components) of the vehicle.

It must be ensured that the adjustment range of the headlight range control complies with potential load levels.

Information

More information about headlight settings can be found in the Volkswagen AG repair information/Maintenance

Manual on the internet:

<http://erwin.volkswagen.de/erwin/showHome.do>

*Information system from Volkswagen AG, subject to payment

2.5.1.2 Mounting special lights

With the use of the customer-specific functional control unit (CFCU), special lights can be installed (e.g. additional turn signals or roof sign for taxi).

Installing special lights increases the end face (see [chapter 1.2.1.8 "Worldwide Harmonized Light-Duty Vehicles Test Procedure \(WLTP\)"](#)).

Please ask your technical service/test centre for advice if you have questions about alternatives. Comply with the country-specific registration provisions when installing special lights.

Observe the following chapters during the conversion:

- [1.2.1.8 "Worldwide Harmonised Light Vehicles Test Procedure \(WLTP\)"](#)
- [8.2.2 "Permissible aerodynamic changes and max. dimensions"](#)
- [3.1 "Body-in-white/Body"](#)
- [3.1.4 "Modifications to the roof of the Caddy Cargo/Caddy"](#)
- [2.5.2.3 "Retrofitting electrical devices"](#)

2.5.1.3 Additional luggage compartment light

If an additional luggage compartment light is required, we recommend installing an additional switch as well as separate wiring (see [chapter 2.5.2.1 "Electrical wiring /fuses"](#); [chapter 2.5.2.2 "Additional electrical circuits"](#) and [chapter 2.5.2.3 "Retrofitting electrical devices"](#)). A solution using a relay with the original lighting wiring is not recommended because the interior lighting is dimmed and switched off by means of PWM (pulse-width modulation signal).

No additional wires may be connected to the existing lighting wiring fitted by Volkswagen AG.

2.5.2 Electrical system

2.5.2.1 Electrical wiring / fuses

The following points shall be complied with if routing modifications are required:

- Specifications according to DIN 72551 or ISO 6722-3 must be complied with
- Avoid routing over sharp edges
- Avoid routing inside excessively narrow cavities and close to moving parts
- No additional lines are must be fastened to brake hoses and brake lines
- Additional lines must remain at a sufficient distance from brake hoses and brake lines under all operating conditions, and must not touch or chafe against such brake hoses/lines under any circumstances
- Only lead-free PVC jacketed cables with an insulation limit temperature >105°C must be used
- Connections must be made professionally and must be water-tight
- The cable shall be dimensioned according to the current drawn and protected by fuses

Max. continuous current [A]	Rated current of fuse [A]	Wire cross-section [mm ²]
0 – 4	5*	0.35
4.1 – 8	10*	0.5
8.1 – 12	15*	1
12.1 – 16	20*	1.5
16.1 – 24	30*	2.5
24.1 – 32	40**	4
32.1 – 40	50**	6
40.1 – 80	100	10
80.1 – 100	125	16
100.1 – 140	175	25
140.1 – 180	225	35
180.1 – 240	300	50

* Shape C; DIN 72581 flat connector

** Shape E; DIN 72581 flat connector

Warning note

No additional electrical wiring or other lines are allowed to be secured to existing lines such as brake lines, fuel lines or cables as standard holders might otherwise be overloaded. An independent attachment solution must be found.

Warning note

Incorrect intervention or installations in the vehicle electrics/vehicle electronics can impair their function. This can lead to a failure of components/functions (S) or safety-relevant parts and consequently to accidents or damage to the vehicle.

2.5.2.2 Additional circuits

If additional circuits are installed, they shall be safeguarded against the main circuit by means of suitable fuses.

The cables used shall be dimensioned according to the load, and protected against pulling off and the effects of impacts and heat.

For Converters of bodies with electromagnetic switching mechanisms (such as relays, magnetic switches, contactors and solenoid valves), these components must be equipped with integrated protective diodes (free-wheel diodes/anti-surge diodes) in order to exclude interference voltage peaks from the vehicle electrical system and the control units. If no protective diodes are integrated, these must be retrofitted antiparallel to the switch coil.

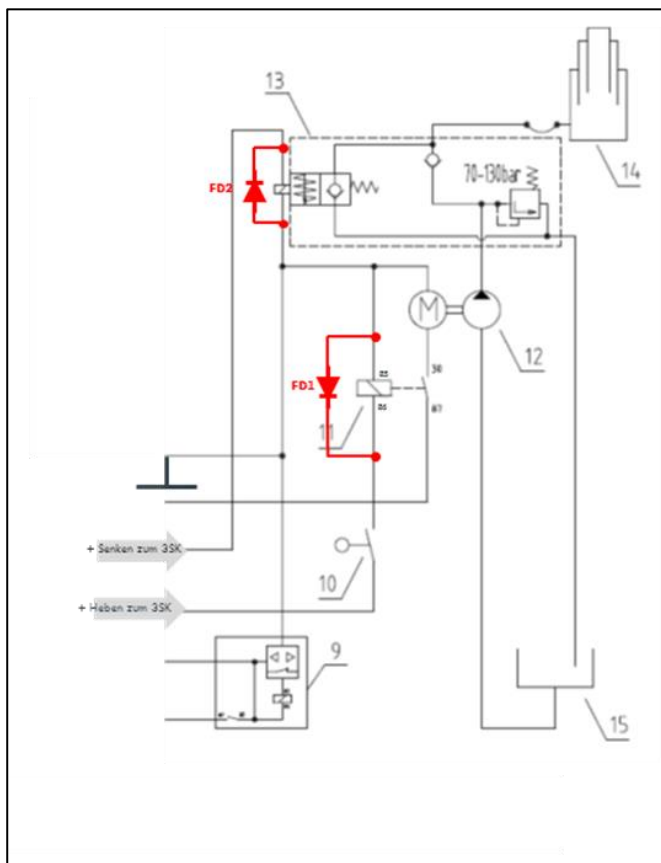

Example of tipper control circuit

- 11 – Electro-hydraulic tipping valve
- 12 – Hydraulic pump with motor
- 13 – Motor relay (lifting tipper bed)
- FD1 – Free-wheeling diode for motor relay
- FD2 – Free-wheeling diode tipping valve

Practical note

For subsequent bodies and conversions for vehicles, it is essential to make sure there are no voltage spikes >150 V in the vehicle electrical system. For conversions, suitable measures must be taken to ensure this (e.g. by using protection diodes).

2.5.2.3 Retrofitting electrical devices

Note the following for retrofitting additional electrical equipment:

- The no-load current of the basic vehicle is optimised at 20 mA. Additional electrical equipment (e.g. data loggers) which is permanently connected to the permanent positive terminal 30 reduces the time after which the vehicle engine can be reliably started by discharging the starter battery. Even 100 mA of additional no-load current takes 2.4 Ah per day from the battery. It is advisable to power this additional electrical equipment with permanent no-load current from the second battery because this is not connected to the starter battery when the vehicle is parked, see [chapter 2.5.4.1 “Installation of additional battery”](#)
- If the electrical power requirement is higher, the alternators approved by Volkswagen for the vehicle must be used
- No further electrical equipment is allowed to be connected to assigned fuses
- No additional cables are allowed to be connected to existing cables (e.g. with insulation-piercing terminals)
- Fuse consumers adequately by means of additional fuses
- All installed electrical devices will be checked acc. to UNECE-R10 and will bear the “E” mark

Depending on the vehicle equipment, electrical auxiliary consumers can be connected to certain unoccupied slots in fuse holder C; see [chapter 2.5.2.7 “Current and signal consumption of vehicle electrical system potentials”](#).

Please also note [chapter 4.9 “Plug-in hybrid electric vehicle \(PHEV\)”](#) on the topic of retrofitting electrical devices, especially for hybrid vehicles.

Warning note

Incorrect intervention or installations in the vehicle electrics/vehicle electronics can impair their function. This can lead to a failure of components or safety-relevant parts and consequently to accidents or damage to the vehicle.

Practical note

The negative terminal of electrical consumers must always be located at the intended body earth and not at the negative battery terminal, as this can lead to falsification of the battery status detection by the on-board electronics.

Information

Interventions in the vehicle electrical system / vehicle electronics can result in invalidation of the warranty/operating permit.

2.5.2.4 Electromagnetic compatibility

Electromagnetic compatibility (EMC) is the property of an electrical system to remain neutral whilst maintaining full functions in the presence of other systems. Active systems in the surrounding area are not disrupted nor is the system itself impaired.

Electrical interference in motor vehicle electrical systems is caused by the different consumers. At Volkswagen, the factory-fitted electric and electronic components have been checked for their electromagnetic compatibility in the vehicle. If modifications are made later on, reductions in comfort (e.g. radio noise) can occur in some cases.

When electrical or electronic systems are retrofitted, their electromagnetic compatibility needs to be checked and certified.

The devices shall possess a type approval acc. to EU Directive 72/245/EEC in the current version, and shall bear the “e” mark.

The following standards/regulations provide information on this:

- CISPR 12
- CISPR 25
- DIN EN 55012
- DIN EN 55025
- ISO 7637
- ISO 10605
- ISO 11451
- ISO 11452
- MBN 10284
- UNECE-R 10

2.5.2.5 Mobile communication systems

1. Mobile phones

Commercially available mobile phones may be operated in the vehicle interior. Observe the respective national regulations for the transmission powers during use. Information about the radio bands can be found in the current vehicle-related manufacturer's declaration. An installation set with external aerial is recommended for an optimum transmission and reception quality and to connect to wireless networks outside of the vehicle. The appropriate interface is available for the mobile phone ex-works as special equipment.

2. Mobile phones for authorities and organisations with security tasks

Two-way radios complying with the technical guidelines of authorities and organisations with security tasks may be installed and operated in the vehicle with the appropriate installation set (according to the vehicle-specific manufacturer's declaration).

Information

For more information on the operation of mobile radio devices, refer to Additional technical information* in the Volkswagen AG conversion portal's Customised Solution Portal.

*Registration required.

2.5.2.6 CAN bus

Warning note

Interventions in the CAN bus and connected components are unauthorised.

The CAN bus must not be modified due to the networking and internal monitoring of electrical equipment (e.g. by interrupting, extending or "tapping", and reading and writing). Any modification to the wiring harness in terms of length, cross-section or resistance could cause failure of safety-relevant components or result in a loss of comfort.

Internal and external vehicle diagnosis is possible via the OBD diagnostic connection (SAE 1962). Each control unit is self-diagnosis capable and has a event memory.

Communication with the control unit can be carried out using ODIS (Offboard Diagnostic Information System) and the software that has been developed for this purpose.

Practical note

The Converter can use the open CAN bus interfaces on the CFCU to exchange predefined data with the BUS system of the base vehicle (CIA 447 or J1939).

Outside of these interfaces and predefined data strings, no data may be exchanged with the internal data bus of the basic vehicle. Furthermore, no online interfaces may be connected to the above CAN bus interfaces (an online interface is an interface that can potentially be connected to the internet, such as *Wi-Fi, Bluetooth, *NFC, *NAD etc.).

In case of non-compliance, the Converter is required to have a new system test performed according to UNECE R 155.

To prevent outside intervention in the vehicle control system, the vehicle manufacturers (OEM) are constantly implementing the UNECE regulations on cyber security (CS) and software update management system (SUMS).

If vehicles are modified or supplemented by Converters following delivery by the vehicle manufacturer, the specifications from the UNECE regulations must also be observed and implemented.

*WLAN = Wireless Local Area Network,

*NFC = Near Field Communication (contactless data transmission using radio frequency identification (RFID) technology),

*NAD = Network Access Device (telephone module)

Information

Your Volkswagen customer service department can provide you with further information.

2.5.2.7 Current and signal take-off of vehicle electrical system potentials

If an electrical interface is not available or, if it is not yet available, a current take-off may take place on a limited basis, taking into account the conditions specified in [chapter 2.5.2.2 "Additional circuits"](#).

Depending on the equipment of the vehicle, the current take-off can take place at certain unassigned positions of fuse holder C (see fig. 1).

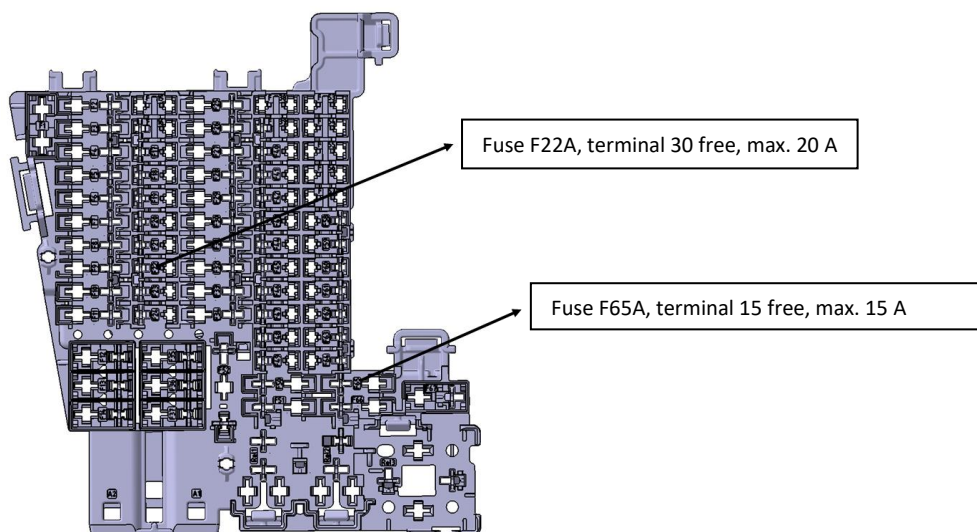

Fig. 1: Fuse holder C left of dash panel

Fuse holder C is located in the bottom left of the dash panel.

- Next to the steering wheel on left-hand drive models
- Behind the glove compartment on right-hand drive vehicles

The exact position and description can be found in the Owner's Manual of your vehicle.

2.5.3 Electrical interface for special vehicles

In principle, there is one interface for external use in special vehicles and by Converters:

- Customer-specific functional control unit (CFCU): control unit with access to the vehicle's CAN network

The interfaces can be ordered using the following equipment numbers (PR numbers).

See the note in the information field below.

PR number	Description
IS0	Without an interface for external use (without an electrical terminal strip), fitted as standard
IS2	Interface for external use (CFCU with Converter programming, without an electrical terminal strip – without preparation for telematics)
IS4	Interface for external use (CFCU without Converter programming, without an electrical terminal strip – without preparation for telematics). The parameterised CFCU IS4 ensures operation and energy management of a retrofitted second battery. The preparation for a second battery can be ordered via 8FV. The CFCU installed here cannot be programmed. If necessary the programming option can be retrofitted; this involves additional costs.
IS9	Without an interface preparation for external use (without an electrical terminal strip)
IP1	Interface for external use (CFCU with Converter programming, without electrical terminal strip – without preparation for telematics) for taxi/private hire car

2.5.3.1 General notes on the interfaces

Basic requirements for using the interface:

- These interfaces are only allowed to be used by authorised specialist personnel
- Inappropriate interventions can result in damage to the vehicle and breakdowns, and may also invalidate the operating permit
- The parameters of the special vehicle control unit are only allowed to be set in consultation with Volkswagen
- Connections must be made properly (see [chapter 2.5.2.1 “Electrical wiring/fuses”](#))
- Subject to technical modifications

The following points must be observed at all times:

- VDE guidelines for configuration and fitting of electrical wiring and components (cable cross sections, fuses etc.)
Only components approved by Volkswagen are allowed to be used for adapting to the vehicle electrical system.
When using additional electrical equipment, the Converter must ensure a balanced current supply.
- EMC safety for connections after the interface is the responsibility of the company fitting out the vehicle
- The cable cross sections of the interfaces will be maintained throughout the entire circuit, i.e. no cross-section reductions are permitted after the interface
- Energy must only be supplied to the vehicle electrical system at potentials expressly provided for this purpose and will be fused externally in accordance with VDE guidelines
- All electrical wiring connected to the vehicle electrical system shall be reliably and durably protected against overload to battery “+”
- Earth potential: The specified potentials always refer to the vehicle body earth

Information

Volkswagen AG Workshop Manuals and current flow diagrams can be downloaded from the Internet at **erWin*** (Electronic Repair and Workshop Information from Volkswagen AG):
<http://erwin.volkswagen.de/erwin/showHome.do>

*Information system from Volkswagen AG, subject to payment

Location of the interfaces

The interfaces are located on the right-hand side of the vehicle above the wheel housing in the area of the rear gate.

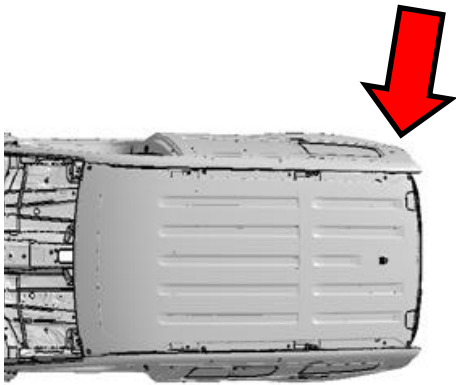

Fig. 1 Coupling point position, viewed from above

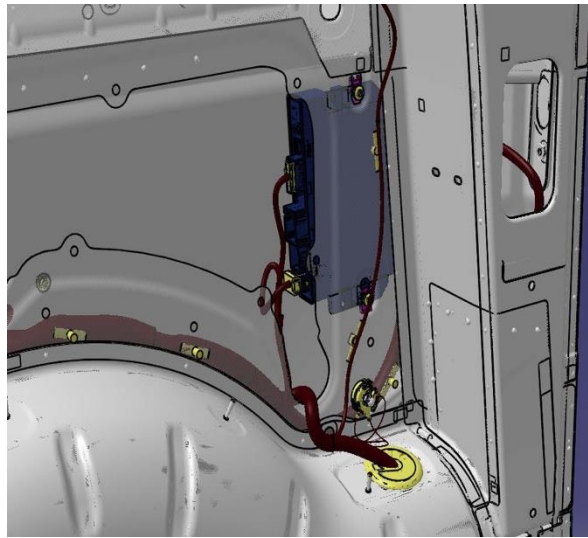

Fig. 2 Coupling point on right rear gate

2.5.3.2 230 V DC/AC converter (PR no. 923, 926)

The DC/AC converter is always installed on the floor of the left seat box (in the direction of travel).

The 230-V socket is located on the partition in the Caddy Cargo (installation position without partition identical) and on the Caddy on the rear centre console. (See figures)

Installation position on the Caddy Cargo

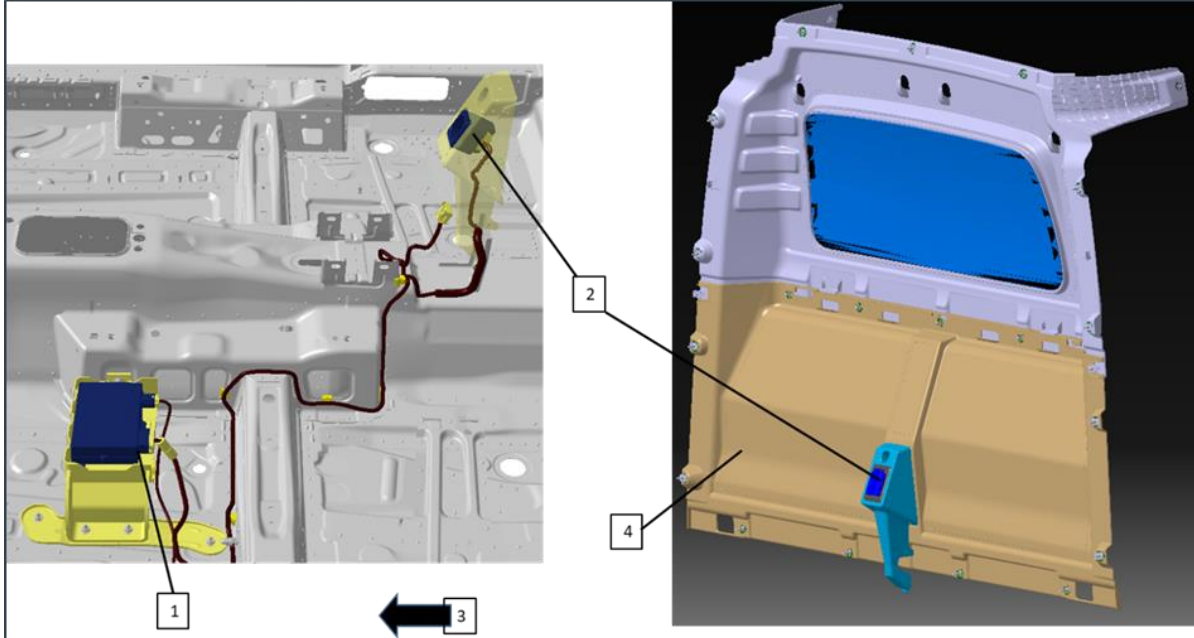

Fig. 1:

- 1 – Location of DC/AC converter, left seat box
- 2 – Installation position of socket
- 3 – Direction of travel
- 4 – Partition

Installation position on the Caddy

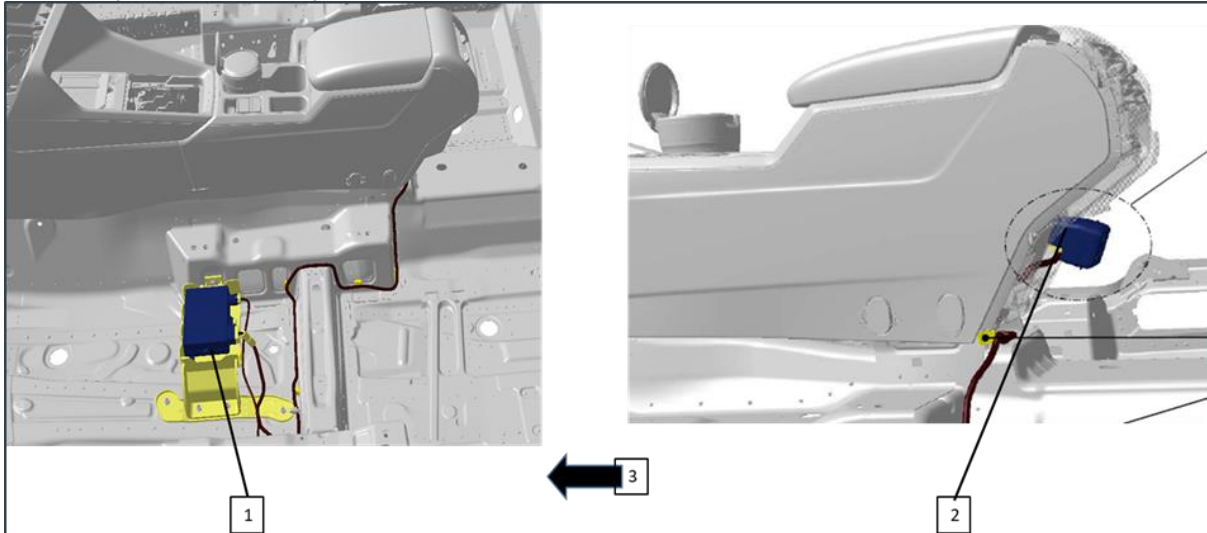
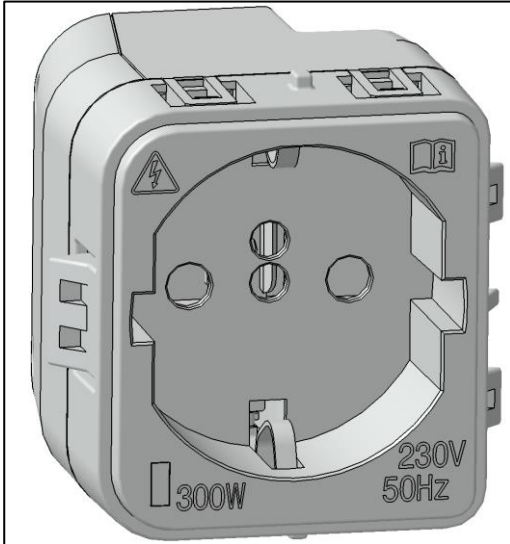

Fig. 2:

- 1 – Location of DC/AC converter, left seat box
- 2 – Installation position of socket
- 3 – Direction of travel

Illustration of the 230-V protective contact socket (PR no. 9Z3)**Illustration of the 230 V protective contact socket for UK and India (PR no. 9Z6)****Functions and features:**

Devices with standard household plugs can be operated in the vehicle. In particular, these include battery chargers,

- 3-pin socket
- 230 V, 50 Hz.
- Peak power 450 W.
- Continuous power 300 W
- Installed in the rear centre console (centre armrest) in the Caddy
- Installed in the cab on the partition in the Caddy Cargo
- The voltage on the socket is switched on by a mechanism integrated in the socket which only switches on the DC/AC converter when a plug is inserted
- When the engine is stopped, the 230 V socket continues operating for up to 10 minutes

2.5.3.3 Customer-specific functional control unit (CFCU)

The functional control unit enables close integration of the base vehicle and the body.

It makes it possible to provide almost 3,000 different signals from the base vehicle that, when required, are used to activate the body functions or are also connected in logic blocks (freely configurable).

Depending on the scope of equipment, the functional control unit also provides a standardised interface for the connection of a telematics system.

In order to adjust the functional control unit to the individual functional requirements of Converters/customers, use the following description and the additional documents and instructions in the login area of the Customised Solution Portal under Technical Information/The Caddy/Functional Control Unit.

- The CFCU (customer-specific functional control unit) includes:
- Programmable and configurable inputs and outputs (e.g. engine speed control)
- ASIL-B Ready (functional safety ISO 26262)
- Display of vehicle information as well as control of the Converter functions
- Ex works functions
- Monitoring of the second battery for the preparation of the second battery

Digital inputs	16
Analogue inputs	8
Outputs	24

Information

All inputs and outputs can be loaded up to the respective specified rated values.

Corresponding technical rated values can be found in the technical customer documentation for the CFCU*.

Overloading can result in damage to the control unit, or even its destruction.

*CFCU: customer-specific functional control unit

Practical note

If additional electrical consumers are installed, in particular factory-fitted optional equipment that use the second battery preparation, a positive overall charging balance shall be ensured by the Converter.

Practical note

The Converter can use what is known as the Converter CAN* (also called J1939 or FMS** CAN) and the CANopen CAN (also called CIA 447) of the CFCU as an external CAN bus to communicate with the base vehicle (for read access to the CAN and in some cases write access as well).

To prevent outside intervention in the vehicle control system, the vehicle manufacturers (OEM) implemented the UNECE regulations on cyber security (CS) and software update management system (SUMS). If vehicles are modified or supplemented by Converters following delivery by the vehicle manufacturer, the specifications from the UNECE regulations must also be observed and implemented.

In the future, it must therefore be technically ensured that no unauthorised messages are written to the respective vehicle CAN via external interfaces or online. External messages on the CAN can affect the basic vehicle's vehicle control system.

The Converter must ensure that no online control units may be connected to the CFCU, in order to minimise this risk.

CAN* Controller Area Network

FMS** Fleet Management System

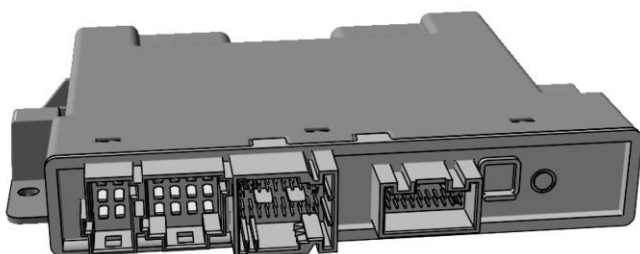

Fig. 1.: View of customer-specific functional control unit

Interfaces

CIA447

J1939

Practical note

Please note: the specified basic functions may already be part of the “ex works functions” and could limit a required configuration and also previously unassigned inputs and outputs.

It is therefore important to clarify in advance whether the required additional CFCU functions are available and therefore usable!

Information

If you have any questions about the content of the configuration of the functional control unit (CFCU), please use the following email address: config-cs@volkswagen.de

Information

Technical documentation on the CFCU and further information regarding the requesting and processing procedure can be found on the Customised Solution Portal via the link:

<https://www.customized-solution.com/de/de/technische-produktinformationen/kfg/technische-information>

You must register on the Customised Solution Portal in order to access this. The configuration of the customer-specific functional control unit (CFCU) can be ordered via the CS portal.

2.5.4 Vehicle battery

If a vehicle is not operated for a long time, its battery gradually loses charge due to the electrical loads (clock, tachograph, cigarette lighter or radio) and can suffer permanent damage (see [chapter 1.2.6 “Recommendations for vehicle storage”](#)).

To prevent this damage, check the battery open-circuit voltage in accordance with the maintenance cycle and charge the battery (see [chapter 1.2.6 “Recommendations for vehicle storage”](#)).

Practical note

Avoid totally discharging the battery. Totally discharging the battery may cause permanent damage to the battery.

When under load, there may be a maximum of 80 A at the battery.

When not under load, the battery voltage must exceed 12.25 V.

When loaded with a maximum of 80 A, the battery voltage must not drop below 11.9 V. If necessary, an open-circuit voltage (electrical equipment off) must be engaged until the open-circuit voltage increases to 12.25 V.

A heavy duty alternator with heavy duty battery is to be used when the engine is running and there is an increase in power requirements. If there is an increased power requirement when the motor is at a standstill or if there is a very high demand for power, a stronger battery should be used.

It is possible to obtain an uprated battery and an uprated alternator from the factory as special equipment for the increased current draw of additional loads:

Order number (PR number)	Designation
NY1	Stronger battery (68 Ah, 380 A AGM battery) and stronger alternator (180 A)
NY2	More powerful battery (68 Ah, 380 A AGM battery)
NY3	Increased alternator capacity (180 A)
J2D	Battery 380 A (68 Ah AGM battery)
JOH	340-A starter battery (58 Ah) Only for plug-in hybrid vehicles (PHEV)*

* Please also observe chapter 4.9 Plug-in hybrid electric vehicle (PHEV)", especially for hybrid vehicles.

2.5.4.1 Installation of additional battery

No additional battery is available ex-works at the moment.

If it is necessary to install an additional battery, this can only be done by a Converter.

The position is defined by the Converter. The Converter bears sole responsibility for installation. Make sure the battery is securely attached and covered. In addition, sufficient ventilation must be provided.

Information

You can order a preparation for second battery including energy management for the Caddy ex-works using PR number: 8FV.
(Not for Caddy PHEV)

This is a “monitored preparation for second battery” with the following functions:

- The control of the supply/second battery charge depends on the second battery charge state (generator voltage, engine start/stop veto)
- Intelligent external charging control (both batteries can be charged with one battery charger by closing the battery isolation relay)
- Information about the starter and second battery charge level on the body system (warning and shutdown levels in the CFCU* signal pool)
- Customer input as regards battery charging possible (maximum alternator voltage for a driving cycle can be chosen by retrospective installation of a charging button)
- EM-P* default configuration
- Automatic recharging of the starter battery from the second battery via the isolation relay if the starter battery has a very low charge level (up to three times per stationary phase)

The preparation is designed for AGM second batteries with the following capacities:

a) 68 Ah	b) 75Ah	c) 92Ah
----------	---------	---------

Preparation:

- Is designed for AGM batteries
- Uses energy management
- Includes:
 - + Coupling point for a second battery data module (BDM) together with 150 A isolation relay and starter box
 - + A positive wire and LIN connector are installed and fused; fuse not installed!
 - + The transfer point in the area of the left seat 1st seat row,
 - + (Installation of the isolation relay as a transfer point and the LIN line,
 - + wire ends rolled up and fitted with a cap protection)
 - + 200-A fuse, as protection between the second battery and the vehicle

CFCU or CFCU preparation required

Activation of the customer-specific functional control unit (CFCU) can be requested after the conversion from the Volkswagen Commercial Vehicle Partner for the following battery capacities by means of the after sales PR numbers:

- a) **O2D** for 68 Ah AGM
- b) **O1N** for 75 Ah AGM
- c) **O1G** for 92 Ah AGM

EM-P* – Standard configuration of the CFCU, which is available ex works, for PR no.: 8FV “Preparation for a second battery”

CFCU inputs/outputs	Plug/pin	CFCU standard configuration as of SW 503	Functional description
Input MFE 9 Digital Low active (Connect earth)	3/23	EM-P charging button (momentary)	Control of the supply / second battery charge depends on the charge level of the second battery (max. alternator voltage and engine start/stop veto)
Input MFE 19 Digital High active (Connect +12 V)	3/8	Internal battery charger active (switching)	With intelligent external charging control with low-power charging sources, the isolation relay remains closed. During activity, an instrument cluster message appears if terminal 15 is on: Charging connector inserted
Output MFA_07 plus switching 5 A from terminal 30_2	2 / 1	Function check of EMP charging rate selector button active	Display of the active charging button function

*Energy management parallel for second battery control

Practical note

For vehicles with the EU6 emission standard, the second battery (from PR no.: 8FV "Preparation of second battery") is operated in an optimum state of charge for reasons of efficiency. This is why the full charge capacity is not always available.

Avoid totally discharging the battery. Totally discharging the battery may cause permanent damage to the battery.

The battery voltage with no load must be more than 12.25 volts.

The battery voltage under load must not drop below 11.9 volts. If necessary, an idle phase (electrical equipment off) must be implemented until the open-circuit voltage increases to 12.25 V.

Practical note

The CFCU* and its programmable interface make it technically possible to temporarily deactivate the engine start/stop system, and to limit the brake energy recovery. Permanent deactivation of the start/stop functions and brake energy recuperation is unauthorised.

* Customer-specific function control unit

Connections to the 2nd battery preparation

The coupling point is located on the inside of the left seat frame in the first seat row.

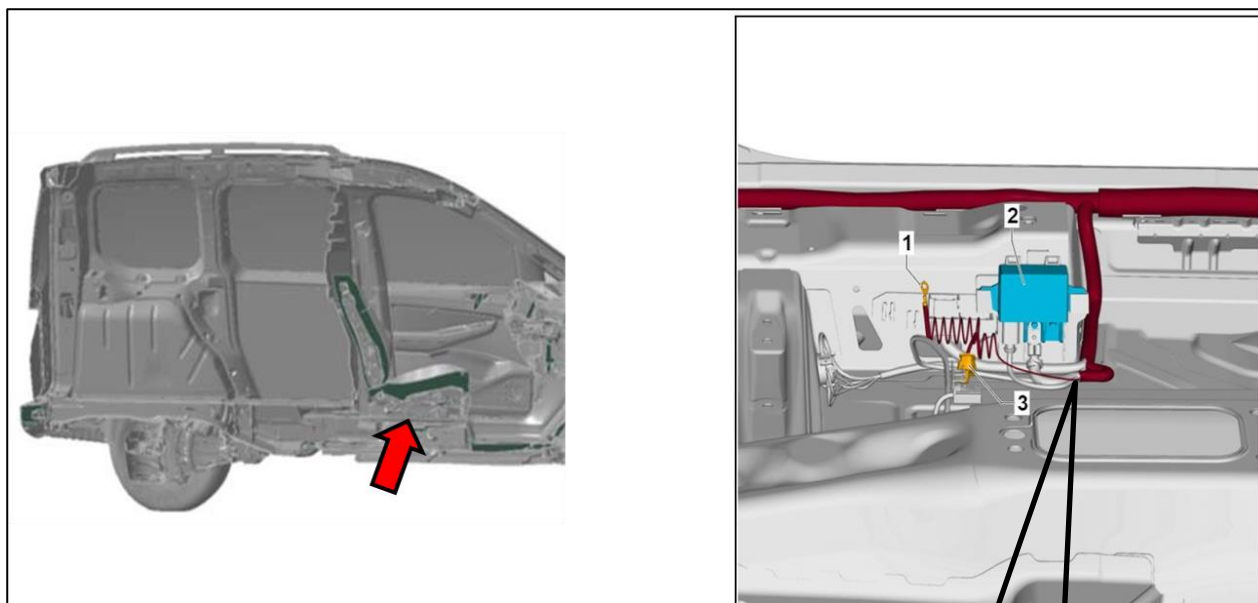

Fig. 1: Position of the coupling point of the preparation

Fig. 2: Seat frame on the left side

For Fig. 2:
 1 – Supply line to second battery to be retrofitted
 2 – Relay and fuse carrier
 3 – Connector for battery monitor

Practical note

Installing an additional battery is only allowed in conjunction with a battery isolation relay. It must also be ensured that the second battery supplying power is protected against reaching the damage threshold/total discharge (for example by installing a voltage monitor).

Warning note

When work is performed on the vehicle electrical system, the earth cables should always be disconnected from the battery and the additional battery. Only then should you disconnect the positive cables.

Short-circuits could occur if this is not observed.

A 50-cm long cable (coming from the control unit) is placed in a wound condition in this area. The Converter can make the connection here. Connector 4F0.973.702 for pairing with the battery data module (BDM).

2.5.4.2 Intelligent external charging control

Note: Only for retrofitted second battery from the second battery preparation (PR no. 8FV)

If a battery charger (3) is connected to the second battery (2) when the engine is off, the energy management in the CFCU* (customer-specific functional control unit) recognises external charging and, upon qualification, instructs the isolation relay to close off (4). The isolation relay does not close when the charge level of the second battery is very low, unless the starter battery cannot be started. In this case, the relay does close and both batteries are charged in parallel.

The relay opens immediately upon switching on ignition (KL15), or upon calling for an engine start (KL50) to avoid taking starter power from the second battery.

If the ignition remains on without engine start, with a connected charging device, the isolation relay closes again after a new qualification period.

Note that the charger used must be able to charge two batteries simultaneously. A capacity of at least 30A is recommended. When using a charger that is not powerful enough or in the event of prolonged trickle charging, the automatic external charging detection may be deactivated for the current stationary phase. For this reason, we recommend the "Battery charger active" +12-V control input* on the CFCU for a permanently installed battery charger.

*See chapter 2.5.3.3 Customer-specific functional control unit (CFCU)

Information

When a permanently installed battery charger is connected to the "Internal battery charger active" control input on the CFCU, the isolating relay to the first battery is opened after one week during a continuous charging process if no further vehicle activities are detected. Vehicle activities might be, e.g. opening the door, CFCU active or current consumption on the second battery. If the charge level of the first battery is too low, or if an activity is detected, the opened relay is automatically closed again.

Practical note

If a solar charging module is retrofitted to the second battery, the automatic external charging detection must be deactivated. If this is not done, the isolation relay may prematurely fail. Solar charging modules must not be connected to the first battery!

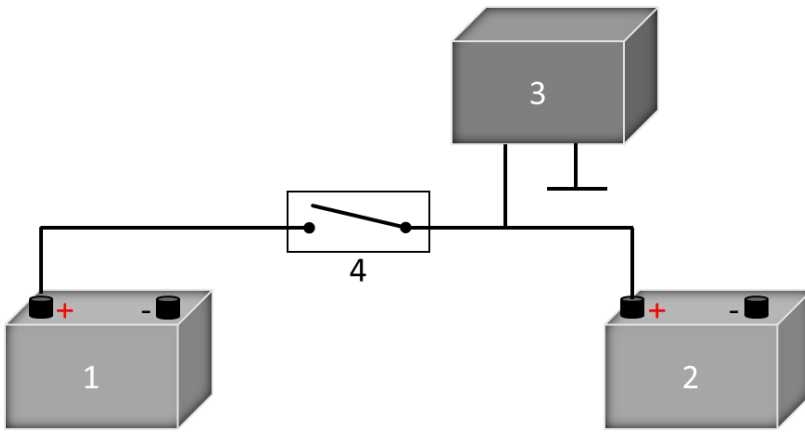

Schematic diagram: External charging control

- 1-Starter battery
- 2-Second battery
- 3-Charging device
- 4-Isolation relay

Practical note

The earth connection on a battery charger must always be connected to an earth point on the vehicle.

*CFU: customer-specific functional control unit, see also [chapter 2.5.3.3](#).

2.5.4.3 Parameterised* reactions on reaching certain second battery charge levels with second battery monitoring

Note: Only for retrofitted second battery from the second battery preparation (PR no. 8FV)

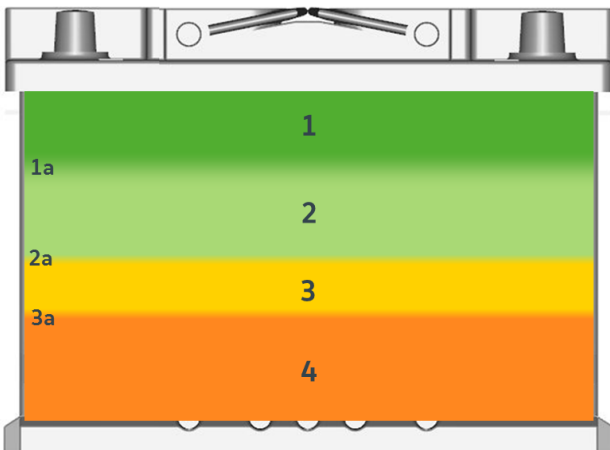

Second battery with continuous load up to 130 A

Charge level		Second battery charge condition	CFCU** signal pool	Vehicle reaction
1	Optimal charge level			
1a	Boundary between charge levels (1) and (2)	Slight recharge required		Alternator voltage 14 V
2	Diminished charge level	Recharge required		Engine start/stop prohibited and Max. alternator voltage***
2a	Boundary between charge levels (1) and (2)		1. Warning level	
3	Low charge level		2. Warning level	Message on the display: "Second battery charge level too low"
3a	Boundary between charge levels (3) and (4)		Shut-off stage	
4	Charge level too low	Only limited battery use possible		

* Parameters can be adjusted according to customer's wish.

** CFCU: customer-specific functional control unit, see also [chapter 2.5.3.3](#)

*** Driver may choose maximum alternator voltage at any time via retrofitted charge button on the CFCU

Practical note

The warning and shut-off stage of the second battery has no effect on the base vehicle. It must be made available for the connected additional electrical equipment using customised calibration of the CFCU.

2.5.5 Retrofitting of alternators

If additional electrical equipment is retrofitted, the increased power requirement can be met by using more powerful alternators.

The following special equipment is available from the factory for this purpose:

Order number (PR number)	Designation
NY1	Stronger battery (68 Ah, 380 A AGM battery) and stronger alternator (180 A)
NY3	More powerful alternator (180 A)

When using additional units, please refer to [chapter 2.7. "Power take-off system for engine"](#).

Please use the PR number ordered to find out which alternator has been installed in your vehicle ex works. The alternator version installed is determined by the equipment ordered in the base vehicle.

In hybrid vehicles, the PR No. 8GJ DC/DC converter is fitted; **no** alternator can be modified.

If other alternators are to be retrofitted, the following points should be observed:

- Vehicle parts and their function should not be impaired by the installation of a generator
- The capacity of the battery and power supplied by the alternator must be dimensioned sufficiently.
- The alternator circuit should be provided with an additional fuse (see [chapter 2.5.2.1 "Electrical wiring/fuses"](#))
- The cable cross-section should be dimensioned according to the current drawn (see [chapter 2.5.2.1 "Electrical wiring/fuses"](#))
- The higher power requirement can make it necessary to replace the starter/alternator warning harness. We recommend Volkswagen genuine parts for this
- Ensure that electrical wiring is routed correctly (see [chapter 2.5.2.1 "Electrical wiring/fuses"](#))
- The accessibility of the ancillaries installed and simple maintenance possibilities may not be impaired
- The necessary air supply and the engine cooling may not be impaired.
- The guidelines of the equipment manufacturer for the compatibility with the base vehicle should be observed
- The Owner's Manual and the maintenance manual for the ancillaries should be handed over when the vehicle is delivered

2.5.6 Driver assist systems

Warning note

Please note: Improper interventions in, or installations in, vehicle systems, safety-relevant components or driver assist systems can impair their function. This can result in failure or malfunctions of components or safety-relevant components. Accidents or damage to the vehicle may occur as a result. In the case of semi-automated driving assistance systems that are part of the type approval, intervention in these systems will invalidate the type approval.

To ensure the correct function of the driver assist systems, it is imperative that the physical limitations of the vehicle described in [chapter 2.1 "Basic vehicle"](#) are observed.

Practical note

The assistance systems are calibrated for the parameters specified in the Certificate of Conformity. If a vehicle is converted within these parameters, calibration is not mandatory.

In particular, the following conditions are required:

- No elevation (lowering)
- "Fields of view" and positions of the sensors must not be altered
- Sensors and their covers must not be covered/painted
- Axle loads and gross vehicle weight rating in accordance with the Certificate of Conformity are complied with

To ensure correct functioning, however, we recommend that the sensors of the driver assist system (nano radars, cameras, front radar) are calibrated by an authorised qualified workshop after the conversion.

If the sensors are removed (this also includes the removal of elements in which the sensors are installed; for example, removing the bumper in the case of the front radar), the systems must be calibrated by an authorised qualified workshop.

Information

Further information concerning the installation and removal of assist systems, such as radars and multifunction camera, can be found in the workshop manuals (repair group 44 Wheels, tyres, wheel alignment) and (repair group 96 Electrical system) on the Internet at **erWin*** (Electronic Repair and Workshop Information from Volkswagen AG): <http://erwin.volkswagen.de/erwin/showHome.do>

*Information system from Volkswagen AG, subject to payment

2.5.6.1 General overview

A variety of active and passive driver assist systems and safety systems are available ex-works. Some assist systems can also be ordered as optional equipment.

The driver assist systems are based on the area monitoring system sensors.

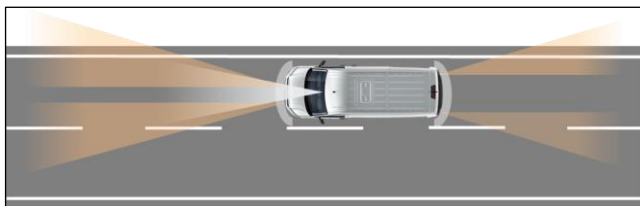

The Caddy has several radar and camera sensors that record the surroundings and analyse and interpret these using intelligent algorithms:

- Front and rear radar sensors
 - The vehicle is fitted with sensors at the front and rear.
 - The sensor in the middle of the front is used for adaptive cruise control (ACC) and for the “Front Assist”.
 - Further radar sensors at the rear record the traffic situation behind. They form the basis of the lane change system “Side Assist” incl. “Blind Spot Monitor”, whose signals are also used by ACC and Front Assist
- The multifunctional front camera is located in the area of the interior mirror and is used:
 - + For vehicle detection (redundancy for radar)
 - + During standstill for monitoring the area in front of the vehicle (automatic restarting of ACC)
 - + For lane information for the lane departure warning “Lane Assist”
 - + For detecting vehicles and other illuminated objects at night for the advanced main-beam control (Dynamic Light Assist)
- Rear camera
 - The reversing camera improves the view to the rear when reversing and delivers a real video image of the area behind the vehicle.
 - The reversing camera can be combined with the radio or navigation devices
- Ultrasound sensors
 - For parking assistance, the vehicle is fitted with up to 12 ultrasonic sensors. The information from the ultrasonic sensors is also included in the ACC regulation

2.5.6.2 Electromechanical steering

The electromechanical power steering has many advantages compared with a hydraulic steering system. It assists the driver and relieves the physical and mental burden for the driver. It works on demand, i.e. only when the driver requires steering assistance. The power steering depends on the vehicle speed, the steering torque and the steering angle which are recorded by sensors and evaluated in the power steering control unit.

In addition, electromechanical power steering enables numerous driver assist systems in which a steering intervention is performed, such as Lane Assist, Park Assist and Trailer Assist.

Warning note

No modifications may be made to the steering rack, the associated components or the control units!

Modifications can result in these systems no longer working correctly and failing. This may result in the driver losing control of the vehicle and causing an accident.

2.5.6.3 Electronic Stability Control (ESC)

ESC is a driving dynamics regulation system that actively regulates both the longitudinal and lateral dynamics.

An extensive system of sensors that constantly compare the actual course of the vehicle with the target course set by the driver allows greater driving stability with ESC.

In all driving situations, ESC contributes to the stability of the vehicle – during acceleration, braking, coasting, driving straight ahead and in corners.

In interaction with the signals from other sensors, a computer checks that the vehicle follows the course set by the driver.

If the vehicle deviates from the target course (understeer or oversteer), a stabilising counter force is applied by braking an individual wheel.

Warning note

The following modifications are not permitted on vehicles with ESC:

- Changing the gross vehicle weight rating
- Modifications to the sensors (steering angle sensor, yaw rate sensor, wheel speed sensor)
- Changing the vibration behaviour at the installation location in the area of the yaw rate sensor by modifying the body
- Modifying the position of components
- Modifications to the chassis
- Modifications to the wheels and tyres
- Modifications to the engine
- Modifications to the steering system
- Modifications to the brake system

The location, position and fastenings of the ESC sensors cannot be modified. Modifications to wiring and ESC components are not permitted. Otherwise the ESC system might no longer function correctly.

Modifications can lead to this system no longer working correctly and to system shut-down and incorrect regulation. This may result in the driver losing control of the vehicle and causing an accident.

2.5.6.4 Tyre Pressure Monitoring System (TPMS)

There are two types of Tyre Pressure Monitoring Systems (TPMS):

1) Indirect Tyre Pressure Loss Indicator (TPLI+)

This standard system (7K1) uses the existing ABS wheel speed sensors to monitor the rotation speed of the tyres. A possible loss of pressure is detected by changes in the rolling circumference and the vibration frequency of the tyres. TPLI+ is a software module that is integrated into the brake control unit and applied to the vehicle. The driver is warned if the tyre pressure falls below the set tyre pressure. The tyre warning light appears in the instrument cluster.

2) Direct measuring tyre pressure monitoring (TPM)

This optional system (7K3) uses additional tyre pressure sensors which are mounted directly on the valves in the tyres and which measure the actual absolute tyre inflation pressure of the tyres. The sensors send the data to the TPM control unit in the vehicle. The driver receives information about the exact tyre pressure of each individual tyre in the infotainment system and warns the driver if the vehicle-specific set target pressure value is not reached. The tyre warning light appears in the instrument cluster.

If the functions of both systems are restricted, the driver is informed of the malfunction. In this case, the tyre warning light flashes for 65 seconds each time the ignition is turned on and off.

The TPMS system (7K3) consists of the following main components:

- 4 Tyre pressure sensors with direction of rotation detection
- TPMS control unit with built-in aerial, installed in an optimal location on the vehicle for reception
- Display in the instrument cluster and operation in the infotainment system

The Tyre Pressure Monitoring System control unit J502 with the Tyre Pressure Monitoring System aerial R175 is located on the cross panel of the body.

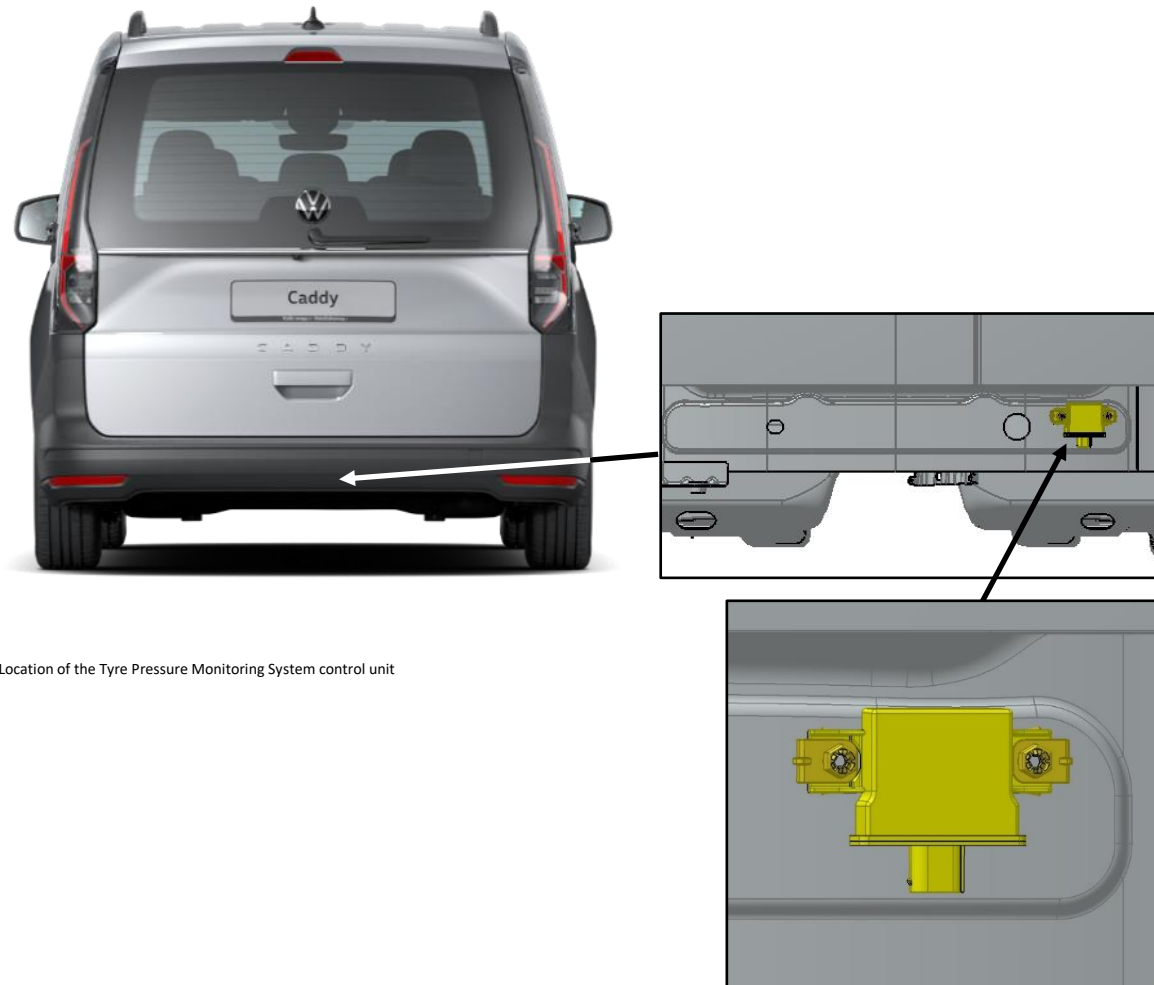

Fig. 1: Location of the Tyre Pressure Monitoring System control unit

Warning note

The position of the TPMS control unit must not be modified. Otherwise there could be a malfunction. As a result the driver may not recognise a loss of tyre pressure and cause an accident. Furthermore the vehicle can in some cases no longer meet the registration requirements.

Warning note

The values published by the vehicle manufacturer in the tyre pressure table must be observed. See the Owner's Manual for your vehicle. The values for the permissible tyre pressures for the different tyre combinations are also shown on a plate on the body. The maximum cold tyre pressure of 5.1 bar must not be exceeded for certain wheel/tyre combinations in conjunction with the TPMS Tyre Pressure Monitoring System.

If tyre dimensions that deviate from the series dimensions are fitted as part of a vehicle conversion, the Converter is responsible for informing the customer about the deviating values for the tyre pressures.

2.5.6.5 Front camera for driver assist systems

The multifunction front camera is built into the mirror base.

The front camera for driver assist systems is installed on the windscreen. It provides information for the driver assist systems Light Assist, Sign Assist, Lane Assist and Adaptive Cruise Control.

The camera operates multiple interfaces in the vehicle. It provides image information with different ranges for the following driver assist systems:

- Front Assist (with Pedestrian and Cyclist Monitoring)
- Lane Assist
- Light Assist main-beam control
- Dynamic Road Sign Display

Practical note

The camera's field of vision must not be obscured. Please observe the notes in [chapter 2.5.6](#).

Warning note

The position of the camera and its surrounds (e.g. changes to standard windscreen or its inclination, add-on parts within the camera's field of view) must not be modified. Otherwise the camera can no longer function correctly and may fail.

2.5.6.6 Rain/light sensor

The rain and light sensor is installed at the top edge of the windscreen, above the rear-view mirror.

Practical note

Vehicles with bodies that project into or cover the sensor cone of the rain/light sensor may impair function. The specifications defined in UNECE-R 48 must be observed.

Practical note

The position of the rain/light sensor and its surroundings may not be modified. Otherwise the rain/light sensor can no longer function correctly.

The rain/light sensor may only be installed with standard windscreens or windscreens available as special equipment. Otherwise there could be a malfunction.

2.5.6.7 Parking aids

The following optional assistance systems are available to help with parking:

- Parking aid in the rear area 7X1
- Park Distance Control at the front and rear 7X2
- “Park Assist” park assist steering and Park Distance Control at the front and rear 7X5

At Volkswagen, the parking aid ensures compliance with UNECE R 158 (reverse travel equipment). For this reason, each vehicle is always fitted with Park Distance Control ex works. Only incomplete vehicles can be ordered without Park Distance Control.

These systems monitor their surroundings using up to 12 ultrasound sensors, known as PDC sensors.

These are installed on the rear and the front of the vehicle.

In the event of superstructures and modifications:

- Add-on parts in the detecting range of the ultrasound sensors can impair the function of the parking aids (e.g. towing bracket, overhanging parts of bodies, hub carrier, steps or bumper guard). In the event of superstructures and modifications, make sure that the ultrasound sensors are not covered by the attachments
- If the bumper is painted subsequently, this must not be done with the ParkPilot ultrasound sensors installed. The coat of paint will impair the transmission and reception of the ultrasound signals
- If approved add-on parts are retrofitted, the parameter set suitable for the ParkPilot must be coded by your authorised repairer

Practical note

Sensors that have already been painted are not allowed to be repainted. Unpainted sensors shall be painted before installation – in order to guarantee the function of the sensors over their service life. You can obtain unpainted and painted sensors in various colours from your authorised repairer.

The coat thickness of the whole painted surface on the membrane is not allowed to exceed 120 µm so that the sensor function is not impaired. This also applies to multiple paint systems and the cathodic dip coating (CDP coating). The thickness of the cathodic dip coating is between 12 µm and 25 µm.

Therefore the coat thickness shall be checked on random samples to ensure perfect function of the sensors.

During painting, make sure that not only the membrane, but also the cylindrical sensor membrane edge is coated evenly with paint at least 2 mm all-round.

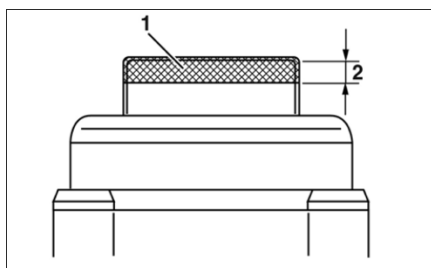

Fig. 1: Painting area of cylindrical sensor membrane edge

- 1 – Painting area
- 2 – Paint coat thickness max 120 µm

Practical note

The paint coat is not allowed to be sanded off mechanically. This could damage the chrome or CDP coat or the sensor membrane.

During the CDP primer process, the paint is not allowed to be removed chemically. This could damage the CDP coat and it can no longer be applied later on. Chemical or mechanical reworking is also not permitted.

2.5.6.8 Lane departure warning “Lane Assist”

The “Lane Assist” lane departure warning uses a camera in the vicinity of the interior mirror to record the lane markings. If there is at least one lane marking, the function is automatically activated from 65 km/h, even in darkness and fog. As soon as the vehicle seems to be leaving the lane, the system emits a visual and haptic (vibration) warning and actively performs compensating steering manoeuvres, within its technical possibilities.

Practical note

Please observe the notes in [chapter 2.5.6](#) and [chapter 2.5.6.5](#)

Information

For more information on calibration of the camera for the lane departure warning system, see the Repair and Workshop Information System (erWin*) operated by Volkswagen AG:
<http://erwin.volkswagen.de/erwin/showHome.do>

*Information system from Volkswagen AG, subject to payment

2.5.6.9 Front assist / ACC

The “Front Assist” area monitoring system monitors the distance to the vehicle in front by means of a radar sensor installed on the front of the vehicle, and it detects critical distance situations.

If an impending collision with a vehicle or a static object is detected, a visual and acoustic warning is given and a short brake jolt triggered. In addition, the brake system may be primed and the parameters of the hydraulic brake assist system reprogrammed.

The function effects automatic braking if an unavoidable risk of collision is detected and there is no brake response by the driver. If the driver brakes heavily when a danger is detected, they are supported in the avoidance of the collision by the brake request being reinforced so far that rear-end collision is, if possible, avoided.

The following must be observed for superstructures and modifications:

- The connection for the radar sensor must not be modified
- The area in front of, around and behind the sensor must never be modified
- Changes to the running gear (brake, wheelbase, track, springs/shock absorbers) can impair the function.
- Do not modify the holder or front apron
- If the bumper cover is subsequently painted, the existing sensors as well as the front radar and its holder must not also be painted
- The permitted axle loads may not be exceeded
- The control units required for the correct functioning of Front Assist, or ACC may not be removed, nor may their function be impaired in any way (see table “Required control units”)

Warning note

Please note: improper interference or installations in vehicle systems, safety-relevant components or driver assist systems (e.g. brakes, wheelbase, track width, springs and shock absorbers, engine management system and ESC) could have an adverse effect on their function and could void system approval. This can also result in failure or malfunctions of components or safety-relevant components. Accidents or damage to the vehicle may occur as a result.

Information

If, for example, a mounting plate for additional devices is to be installed in front of the radar sensor, please contact Volkswagen Customer Care in the planning phase (see [chapter 1.2.1 "Product and vehicle information for Converters"](#)). The road traffic regulations in the countries of registration must be observed and coordinated with the responsible test centre or technical service.

2.5.7 Earth points

Use the earth points provided by Volkswagen for subsequent electrical add-ons or installations to ensure an optimum earth connection to the basic vehicle.

Warning note

The use of other earth points can lead to malfunctions in safety systems. This can lead to a failure of components or safety-relevant parts and to fault messages in the instrument cluster.

A maximum of 4 terminals are allowed to be screwed to an earth point.
The earth points of the safety systems are not allowed to be used for bodies.

Information

A general overview and more detailed information about earth points can be found in the current wiring diagram.

Volkswagen AG repair and workshop information can be downloaded from the Internet at erWin* (Electronic Repair and Workshop Information from Volkswagen AG):

<http://erwin.volkswagen.de/erwin/showHome.do>

*Information system from Volkswagen AG, subject to payment

In the case of further requirements, please contact us (see [chapter 1.2.1 "Product and vehicle information for Converters"](#)).

2.6 Engine peripherals/drive train

In the event of modifications to noise-relevant components such as the engine, exhaust system, tyres, air intake system etc., noise measurements shall be carried out acc. to EC Directives. The permitted values are not allowed to be exceeded.

The national regulations and directives apply.

Components for noise insulation which are installed as standard are not allowed to be modified or removed (see also [chapter 2.4.4 "Acoustic insulation"](#)).

2.6.1 Engine / drive train components

No modifications to the engine air intake system are permitted.

Subsequent solutions regarding engine speed control are not possible.

Modifications to the cooling system (radiator, radiator grille, air ducts etc.) are not permitted.

Keep cooling air intake areas clear.

2.6.2 Drive shafts

The correct configuration and implementation of a modified powertrain prevents noise and vibration, and should only be performed by a company which is qualified to build drive shafts.

Only genuine Volkswagen parts should be used.

2.6.3 Fuel system

Modifications to the fuel system should be avoided, and any such modifications may result in invalidation of the vehicle's operating permit.

If it is necessary to modify the fuel system for the conversion, the Converter is solely responsible for ensuring a proper design, for proper functioning of the system, including all components used, and for the materials used.

Sufficient clearance to all adjacent components must be ensured. The ground clearance must not be restricted compared to the standard production vehicle. Particular attention must be paid to the effect of heat from the exhaust system and the modified tank. If thermal protection parts are removed from the production vehicle, they must be replaced in a suitable manner. A new operating permit must be applied for from the registration authority.

Practical note

If the fill level indicator does not function properly, the components in the fuel system and the engine may be damaged.

Information

Volkswagen Commercial Vehicles does not support adaptation of the fuel gauge to the modified fuel system.

Comply with the following points if making any modifications to the fuel system:

- The whole system must be permanently leak-proof in all operating conditions
- Ensure good quality refuelling if modifications are made to the tank filler pipe, and avoid any syphon effect in the pipe routing
- All components that come into contact with fuel shall be suitable for the particular type of fuel used (e.g. petrol/diesel/ethanol additive etc.) and the ambient conditions in the installation location
- Hoses must retain their shape and remain adequately stable throughout the service life, in order to ensure that there is no constriction in the cross section (e.g. 4-layer hoses acc. to DIN 73379-1)
- Multi-ply hoses should be favoured
- Install reinforcing support sleeves at the connections between hose sections so as to prevent any constriction at the clip connection and to guarantee air-tightness
- At the connections, use spring-type clips which automatically compensate for possible settling behaviour of the material and to maintain the preload. Hose clips with worm threads must be avoided
- All parts of the fuel filler system must be routed at a sufficient distance from moving parts, sharp edges and components at high temperature, in order to avoid damage
- In vehicles with a petrol engine (also applies to hybrid vehicles), there is an activated charcoal filter in the area of the rear left wheel housing. The location of the activated charcoal container and its purge line to the engine must not be changed. The same applies to the location of the fresh air intake
- In hybrid vehicles, a shut-off valve (FTIV fuel tank isolation valve) is also fitted to the activated charcoal filter and a pressure sensor is fitted on the fuel tank
- **Caution:** In a hybrid vehicle, an internal tank pressure of up to 400 mbar may occur
- The entire ventilation concept for the fuel tank must be left unmodified
- In hybrid vehicles, a special requirement is placed on the function of the ventilation system. If changes cannot be avoided, special care must be taken during the conversions
- Do not attach heat-conducting components or components that restrict the installation space
- Modifications to the fuel pump, fuel line length and fuel line routing are not permitted. Modifications to these mutually matched components can impair the function of the engine
- Modifications to the body in the area of the fuel tank require the fuel tank to be removed first
- If the Converter replaces the standard tank with a different fuel tank, it must be ensured that the ground clearance with the new tank is not less than that with the standard tank
- If the Converter changes the position of the standard tank, the fuel gauge sender and the fuel gauge must be recalibrated. If a fuel tank that differs from the standard is used, for example for vehicles for special applications (e.g. vehicles for transporting people with disabilities), exceptions are possible. Please contact us (see [chapters 1.2.1.1 “Contact in Germany”](#) and [1.2.1.2 “International contact”](#)).

Comply with the workshop manuals of Volkswagen AG.

Information

Volkswagen AG repair and workshop information can be downloaded from the Internet at **erWin*** (Electronic Repair and Workshop Information from Volkswagen AG):
<http://erwin.volkswagen.de/erwin/showHome.do>

*Information system from Volkswagen AG, subject to payment

2.6.3.1 CNG* fuel system

The Caddy CNG* is designed as a monovalent vehicle (petrol tank smaller than 15 litres).

Fuel level in five natural gas reservoirs and petrol tank.

Drive: 1.5 l TGI engine with 96 kW.

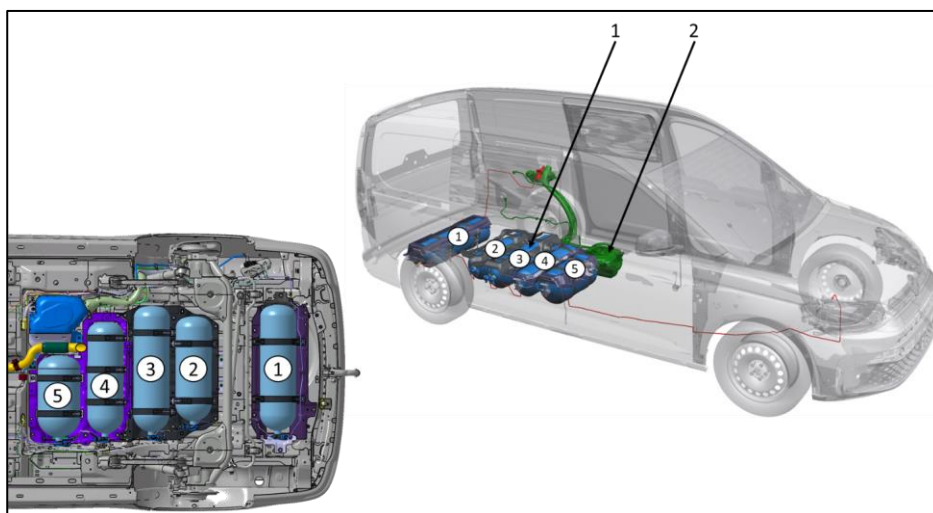

Fig. 1: Schematic diagram, view of gas and petrol tank

- 1 – Natural gas fuel tanks
2 – Petrol tank

* Compressed Natural Gas

	Steel cylinders
Container 1	Ø235 x 860 (30.5 l)
Container 2	Ø235 x 720 (25 l)
Container 3	Ø235 x 860 (30.5 l)
Container 4	Ø235 x 765 (27 l)
Container 5	Ø280 x 570 (26 l)
Total volume of natural gas	139 l
Fill weight gas catalogue	21.1 kg
	Emergency tank
Petrol fill volume	8.25 l

Warning note

Modifications to the CNG fuel system are not permitted!

Special care must be taken when working on the body near the vehicle floor and the filling openings to prevent damage to the gas tanks, gas pipes, sensors and electrical supply lines.

2.6.4 Exhaust system

Modifications to the exhaust system up to the centre silencer and in the area of the components for exhaust post-treatment (diesel particulate filter, catalytic converter, lambda probe etc.) are never permitted.

If a modification to the exhaust system due to body design, removal or conversion is nevertheless required, this can have consequences relevant to registration. Please contact us in advance regarding the scope of your conversion so that we can advise you.

We recommend that you use VW genuine parts and comply with the workshop manuals of Volkswagen AG.

Information

You will find further information on installation and removal of the exhaust system on the Internet at **erWin*** (Electronic Repair and Workshop Information from Volkswagen AG):
<http://erwin.volkswagen.de/erwin/showHome.do>

*Information system from Volkswagen AG, subject to payment

Information

Country-related regulations and guidelines shall be complied with

Exceptions require the approval of Volkswagen AG before the conversion, and shall be documented in a registration report detailing the modifications and adjustments made.

Please contact us before starting a conversion (see [chapter 1.2.1, "Product and vehicle information for Converters"](#)).

Warning note

Attention! Danger of fire!

The lengths and routings of the exhaust system have been configured optimally with regard to their temperature properties. Modifications may result in relatively high to extreme heating of the exhaust system and the surrounding components (drive shafts, tank, floor pan etc.).

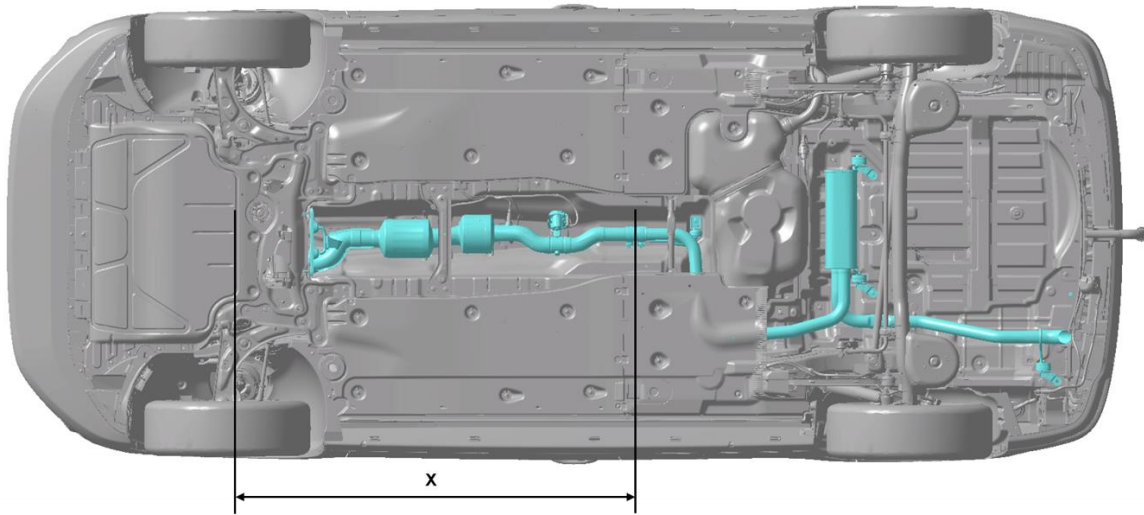

Fig. 1: Caddy exhaust system with SCR system

X – Area in which modifications are not permitted

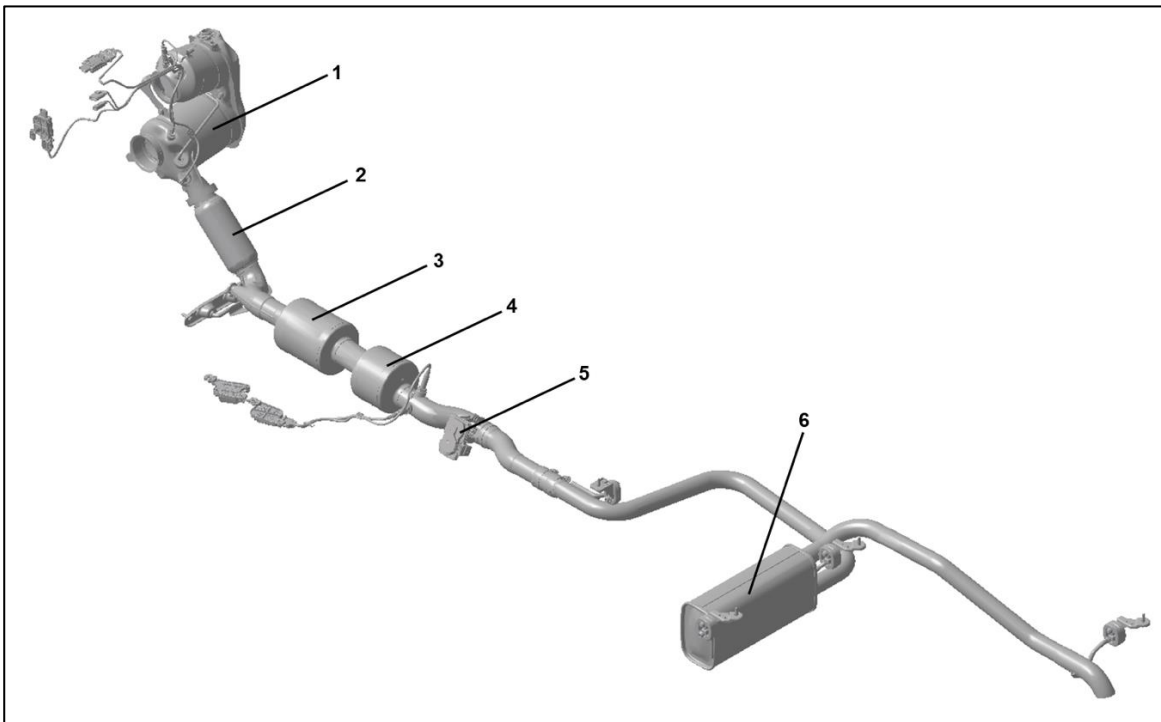

Fig. 2 Emission control with SCR system

- 1 – Emission control
- 2 – Damper element
- 3 – Converter
- 4 – Converter
- 5 – Exhaust control flap
- 6 – Front and rear silencers

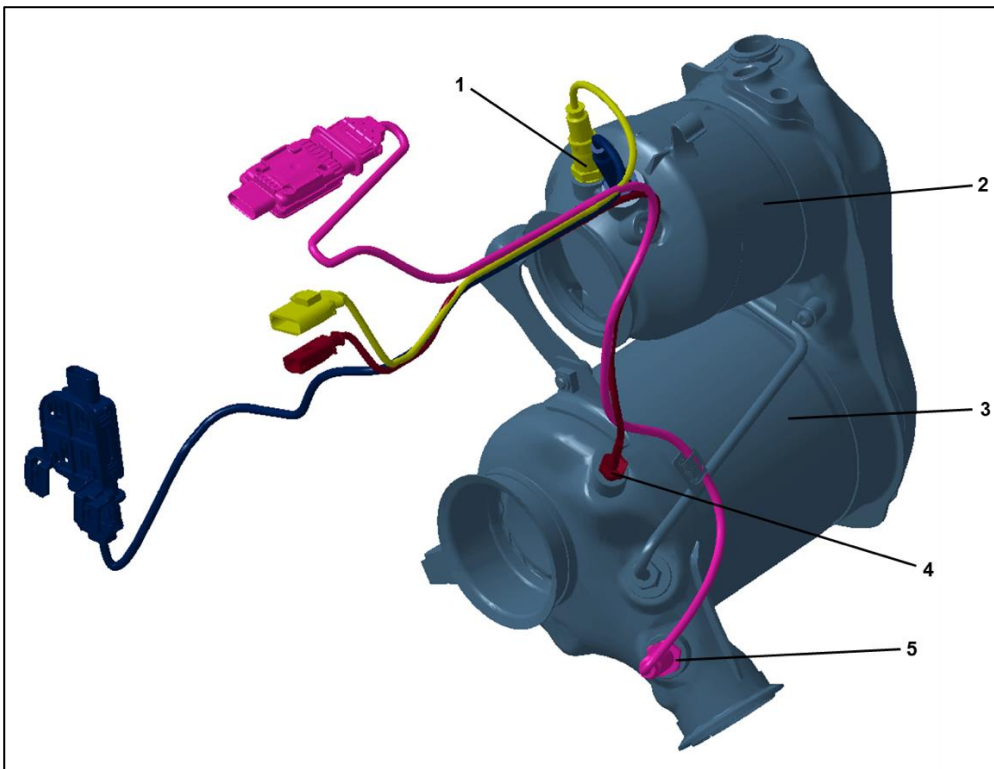

Fig. 3: Emission control

- 1 – Lambda probe
- 2 – Pre-converter
- 3 – Particulate filter
- 4 – Temperature sensor
- 5 – NOx sender

Modifications to exhaust systems with an SCR system are not authorised under any circumstances. Neither the geometry nor the position of the sensors are allowed to be changed.

If a modification is required to the exhaust system for the add-on/removal/conversion nevertheless, this can have effects which are relevant to registration. Please contact us in advance regarding the scope of your conversion so that we can advise you.

Changes as a result of add-ons or conversions are only possible outside of the SCR emission control area indicated by X (see Fig. 1 Exhaust system with SCR system).

Practical note

When working on lines carrying AdBlue®, comply with the workshop manuals from Volkswagen AG. Otherwise, AdBlue® could crystallise and lead to damage to system components.

2.6.4.1 Hybrid powertrain exhaust system (PHEV)

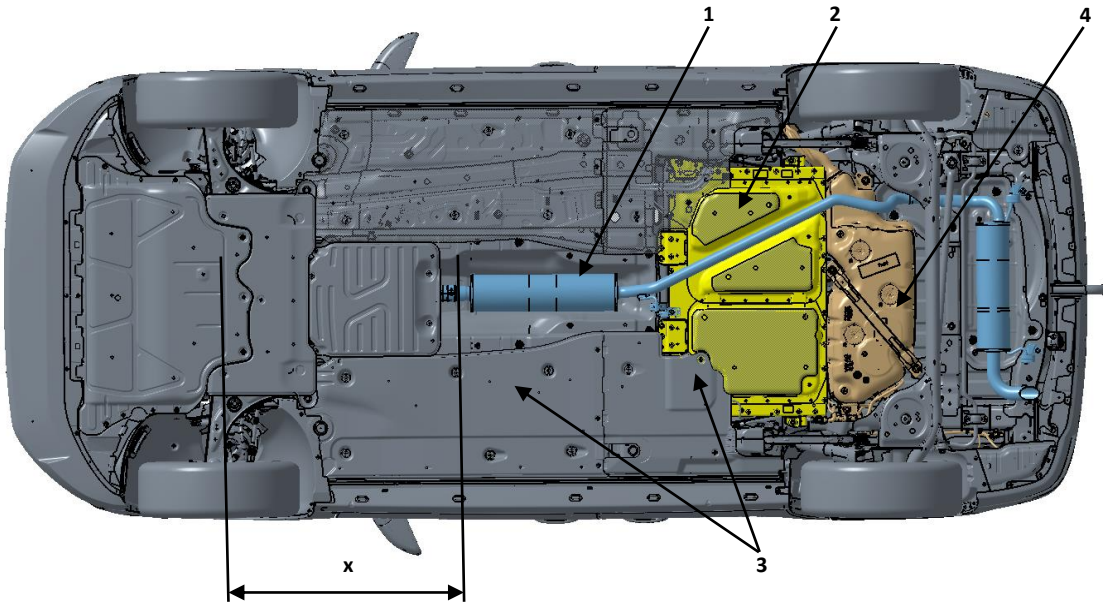

Fig. 1: PHEV exhaust system, short wheelbase (illustration: 4x2 drive type, 85KW TSI)

- 1 – Exhaust system
- 2 – Battery
- 3 – Trim (the left underside of the vehicle is shown without trim)
- 4 – Fuel tank
- X – Area in which modifications are not permitted

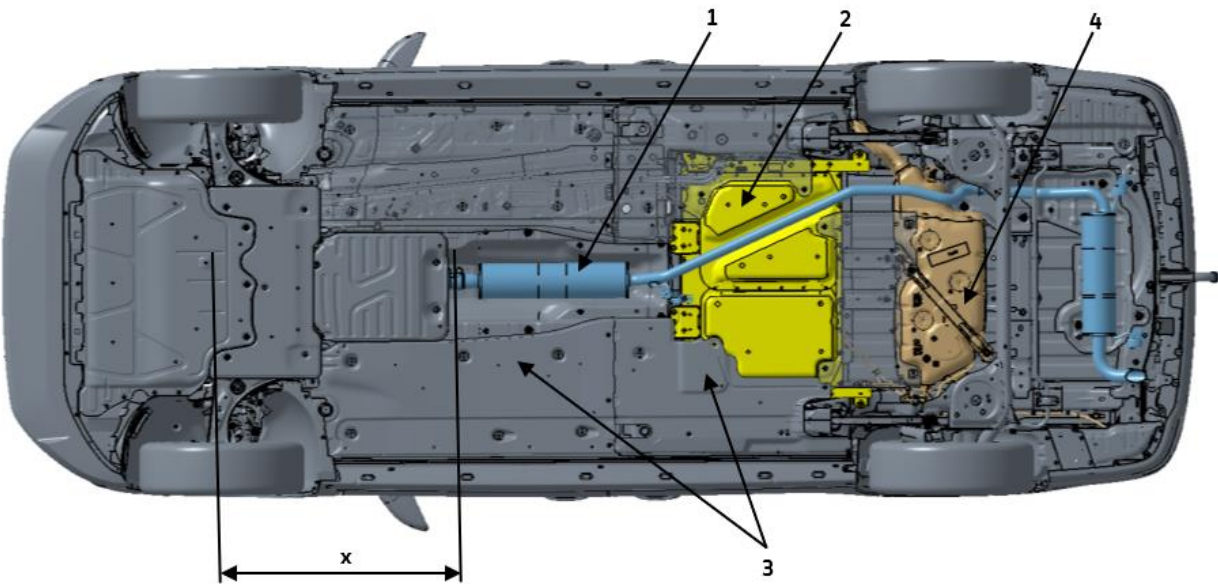

Fig. 2: PHEV exhaust system, long wheelbase (illustration: drive type 4x2, 85KW TSI)

- 1 – Exhaust system
- 2 – Battery
- 3 – Trim (the left underside of the vehicle is shown without trim)
- 4 – Fuel tank
- X – Area in which modifications are not permitted

2.6.4.2 4x4 drive exhaust system

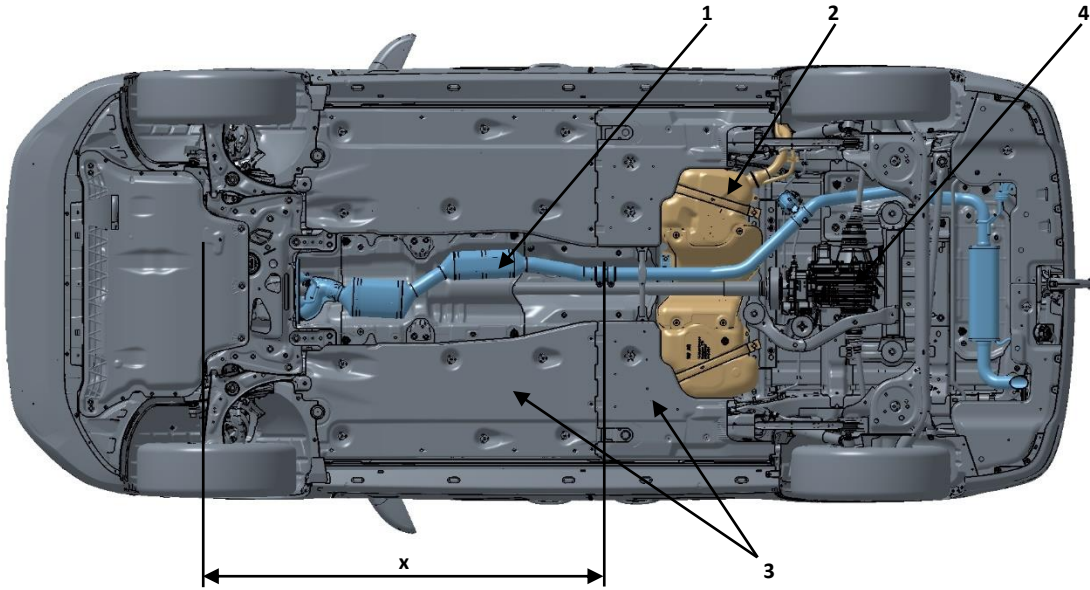

Fig. 1: 4x4 drive exhaust system (all-wheel drive), short wheelbase (illustration: 4x4 drive type, 90KW TDI)

- 1 – Exhaust system
- 2 – Fuel tank
- 3 – Trim
- 4 – Rear final drive
- X – Area in which modifications are not permitted

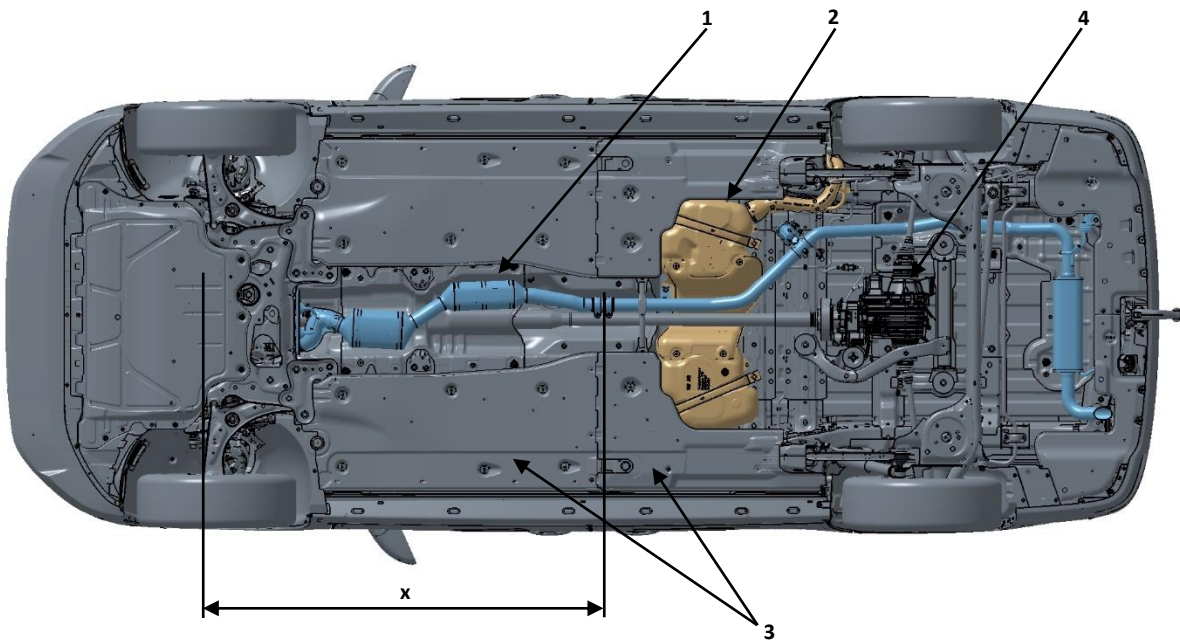

Fig. 2: 4x4 drive exhaust system (all-wheel drive), long wheelbase (illustration: 4x4 drive type, 90KW TDI)

- 1 – Exhaust system
- 2 – Fuel tank
- 3 – Trim
- 4 – Rear final drive
- X – Area in which modifications are not permitted

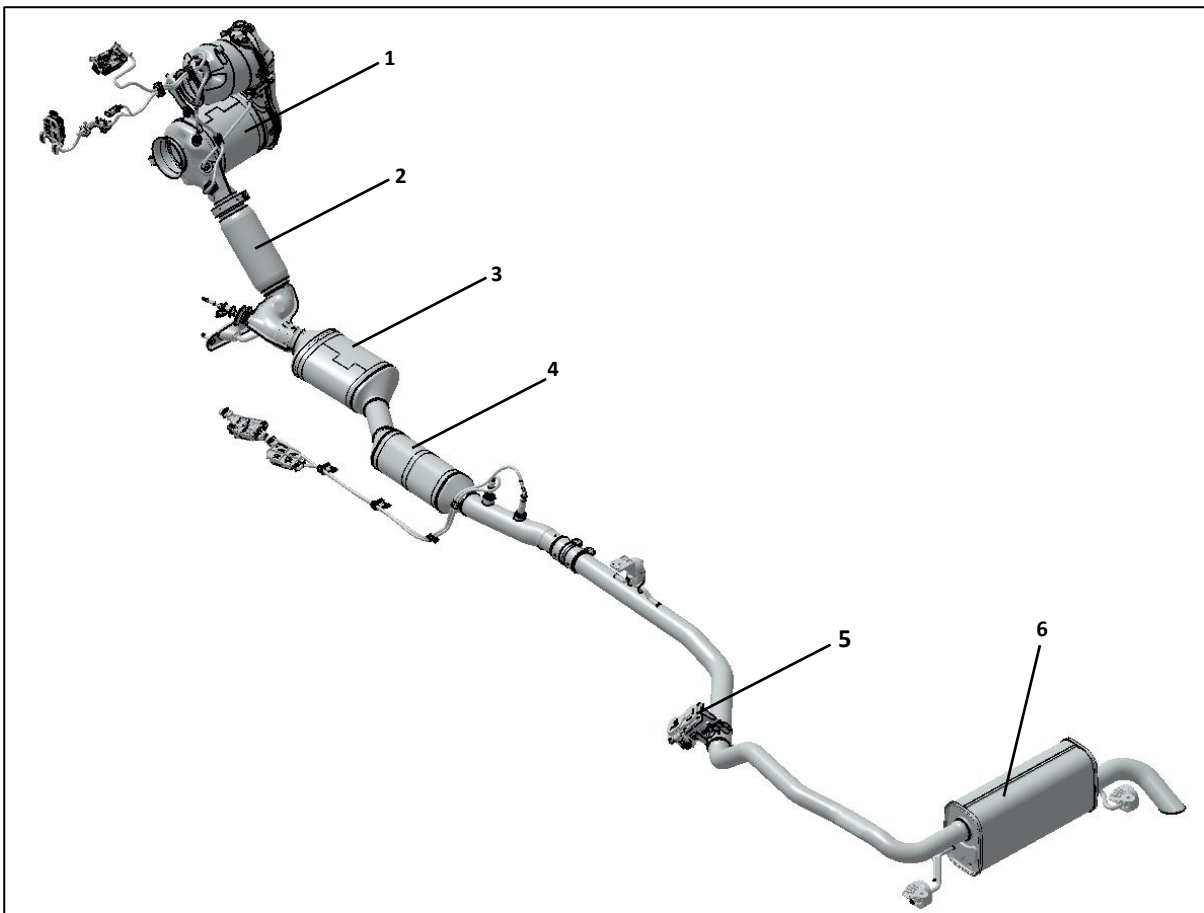

Fig. 3: Emission control with SCR system

- 1 – Emission control
- 2 – Damper element
- 3 – Converter
- 4 – Converter
- 5 – Exhaust control flap
- 6 – Rear silencer

Practical note

If a modification to the exhaust system due to body design, removal or conversion is required, this can have consequences relevant to registration.

2.6.5 SCR system (EU6)

To meet EU6 emissions regulations for diesel engines, engines are available ex-works with different performance levels with the SCR system.

Selective Catalytic Reduction (SCR) is a process used in automotive engineering for diesel vehicles to reduce emissions.

The SCR catalytic converter selectively converts the nitrogen oxide (NOx) exhaust component into nitrogen and water. This conversion is undertaken using AdBlue®, a synthetically manufactured, aqueous reducing agent. AdBlue® comprises 32.5 per cent high-purity urea and demineralised water. The AdBlue® solution is not mixed with the fuel, but carried in a separate tank.

From here, the AdBlue® is injected continuously into the exhaust gas line in front of the SCR catalytic converter. The AdBlue® reacts with the nitrogen oxides in the SCR catalytic converter and is split into nitrogen and water. The dosing is determined by the exhaust mass flow. The engine management system is informed by an NOx sender after the SCR catalytic converter and ensures exact dosing. The AdBlue® reducing agent is non-poisonous, odourless and water-soluble.

2.6.5.1 Installation position of the AdBlue® tank in the vehicle



Fig. 1: Installation position of the AdBlue tank in the vehicle

1 – AdBlue tank

The SCR system consists of the AdBlue tank, hose and metering valves and forms an optimised electrical-hydraulic unit. The location of the reducing agent tank, the heated metering line and their relative position to the vehicle shall not be changed (see [chapter 2.6.4 “Exhaust system”](#)).

2.6.5.2 Filling the AdBlue tank

The filling opening of the reducing agent tank is located behind the tank flap.

The capacity of the reducing agent tank is approx. 15 litres.

Practical note

Once a particular residual range is reached, the display on the instrument cluster displays a reminder to top up the reducing agent.

Reducing agent consumption depends on the individual driving style, and can be up to 1.5% of fuel consumption.

When the AdBlue® tank is empty, the vehicle can only be driven at reduced power and lower engine torque.

When topping up AdBlue® within the remaining range display, add at least the minimum refill quantity that is displayed in the instrument cluster. An adequate amount of AdBlue® shall be replenished when the residual range reaches about 1000 km, if not sooner.

Never run the reducing agent tank empty.

Practical note

AdBlue® attacks surfaces such as painted surfaces, aluminium, plastics, clothing and carpets. If AdBlue® is spilled, wipe it up as quickly as possible with a damp cloth and plenty of cold water. Remove crystallised AdBlue® with warm water and a sponge. More information about AdBlue® is available in ISO standards ISO 22241-1 to 4.

Practical note

To ensure the purity of AdBlue®, never reuse AdBlue® that has been extracted from the reducing agent tank.

Comply with the laws and regulations of the country in question regarding correct storage and disposal.

Information

More information and safety instructions for the SCR system can be found in the Owner's Manual for your vehicle and the Workshop Manuals of Volkswagen AG on the Internet:

<http://erwin.volkswagen.de/erwin/showHome.do>

2.7 Engine power take-off systems

When planning the special vehicle, select the equipment of the base vehicle according to the requirements of the future application (see [chapter 1.3.1 “Selecting the base vehicle”](#)).

You can optimise your base vehicle for the conversion in advance by selecting the following special equipment items:

- Stronger alternator (see [chapter 2.5.5 “Retrofitting of alternators”](#))
- Battery in stronger execution (see [chapter 2.5.4 “Vehicle battery”](#))
- Electrical interface for special vehicles (see [chapter 2.5.3 “Electrical interface for special vehicles”](#))

Practical note

In vehicles with a high proportion of engine running times with the vehicle stationary (working mode), the normal maintenance intervals specified by Volkswagen AG for the belt drive (poly V-belt, tensioning pulley, idler roller etc.) shall be reduced according to the application and customer profile.

Hybrid vehicles do not have an engine power take-off system (belt drive). It is therefore not possible to retrofit alternative air conditioning compressors or generators.

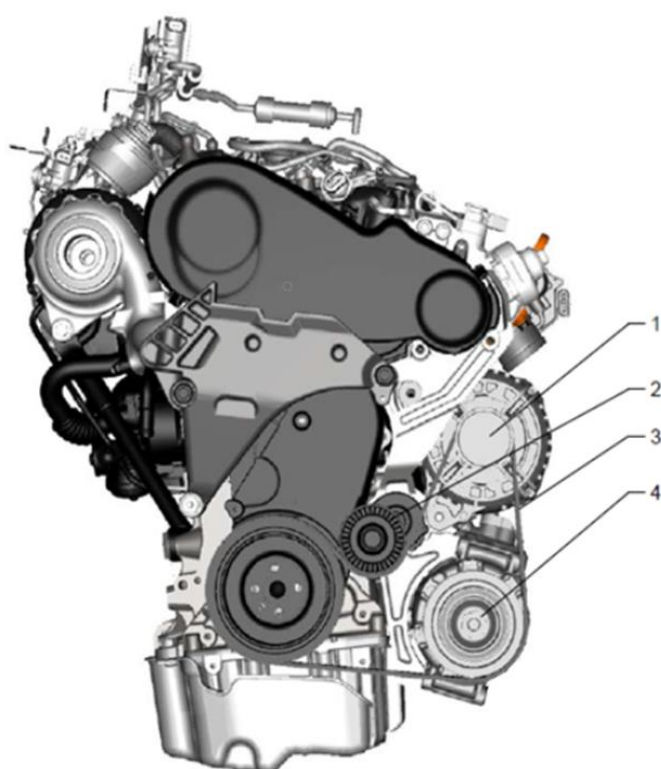

Fig. 2: Schematic diagram: poly V-belt drive

- 1 – Alternator
- 2 – Belt tensioner
- 3 – Poly V-belt
- 4 – Air conditioner compressor

2.7.1 Compatibility with base vehicle

If retrofitting or renewing ancillaries such as the refrigerant compressor, ensure that these are compatible with the base vehicle.

It is also essential to comply with the following points:

- Vehicle parts and their function should not be impaired by the installation of an air conditioning system
- The capacity of the battery and power supplied by the alternator must be dimensioned sufficiently.
- Additional fuse protection of the air-conditioning system circuit (see [chapter 2.5.2.1 “Electrical wiring/fuses”](#))
- The refrigerant compressors should be mounted on the subframes provided
- The weight of the ancillary unit is not allowed to exceed the weight of the original refrigerant compressor (see [chapter 2.7.4.2, “Weight of the refrigerant compressor”](#))
- The diameter and position of the drive pulley for the ancillary must correspond with that of the original refrigerant compressor. (see table in [chapter 2.7.4.2](#))
- There must be adequate space for operating the ancillary
- The track position of the poly V-belt must be identical to the original and the poly V-belt specifications must be observed (see [chapter 2.7.4.4, “Specification of the poly V-belt”](#))
- The specifications for the pulleys must match the specifications for the poly V-belt exactly (identical width and number of grooves, e.g. 6PK)
- To ensure the belt is guided properly, “shouldered washers” (with leading edge) must be used
- Ensure that lines (brake hoses/cables and wires) are routed correctly
- The accessibility of the ancillaries installed and simple maintenance possibilities may not be impaired
- The Owner’s Manual and the maintenance manual for the ancillaries should be handed over when the vehicle is delivered
- The necessary air supply and the engine cooling may not be impaired.
- When compact systems (evaporator, condenser and blower) are mounted on the cab roof, the permitted roof loads may not be exceeded (see [chapter 2.3.1 “Maximum roof loads”](#))
- Attachments to the roof require a letter of non-objection from the responsible department (see [chapter 1.2.1, “Product and vehicle information for Converters”](#))
- If the standard refrigerant system is modified, the fill volumes of refrigerant and refrigerant oil must be redefined and indicated accordingly on a plate in the vehicle
- In order for a letter of non-objection to be issued, it is necessary to submit documentation relating to the design of the additional auxiliary drives, specifying the tolerance position, to Volkswagen AG
- Standard dynamic belt tensioners with spring/shock absorber systems should always be used. Rigid belt tensioning elements are not allowed to be used
- It is of great importance that the dynamic properties of the belt drive should be investigated in operation, or ideally that a belt dynamics measurement should be performed

Practical note

In vehicles without an air conditioning system, conversion using the measures code is also required when an additional unit is retrofitted.

Practical note

Please note that subsequent modifications to the factory-fitted air conditioning system by the Converter are solely the responsibility of the Converter. In such cases, Volkswagen is unable to make any statement about the lubrication of the compressor and the effects on its service life.

As a result, Volkswagen AG does not offer any warranty for the compressor in this case.

In order for the warranty to be retained, it would be necessary for an extensive measurement of the oil circulation in the refrigerant circuit to be carried out.

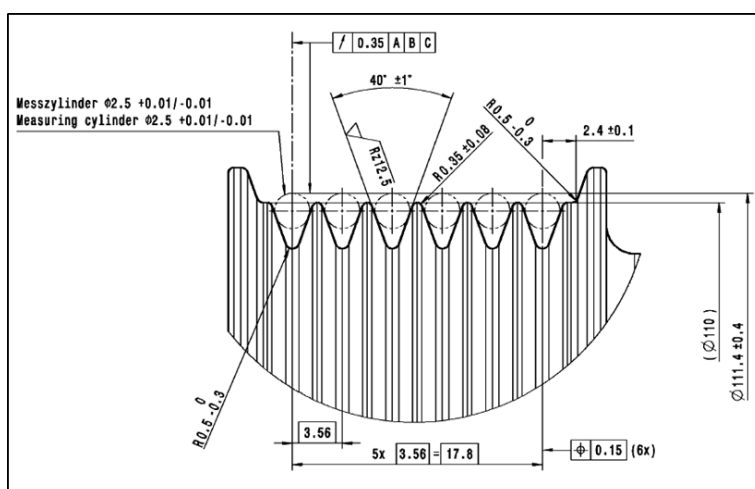

Fig. 1: Detail U – Drive pulley for refrigerant compressor (example DENSO 7SAS17)

Please observe the installation and removal regulations from Volkswagen AG when performing conversions.

Information

For detailed instructions about the installation and removal, for example, of the poly V-belt, refer to the Workshop Manuals of Volkswagen AG on the Internet under **erWin*** (ElectronicRepair and Workshop Information from Volkswagen AG):

<http://erwin.volkswagen.de/erwin/showHome.do>

*Information system from Volkswagen AG, subject to payment

2.7.2 Retrofitting air conditioning system

To retrofit air conditioning systems, we recommend the manual air conditioning system with the PR number KH6 or the Climatronic air conditioning system with the PR number 9AK, that you can buy ex-works as special equipment, and use of the genuine refrigerant compressor:

Engine designation		Air-conditioned area	Refrigerant compressor type	Refrigerant	Capacity [cm ³]	Component no.
EA288evo TDI 2.0 l	2.0 l TDI	Cab and vehicle interior	DENSO-6SAS14 with magnetic clutch	R1234yf	140	3Q0 816 803 D
EA211evo TSI 1.5 l EU 6 Plus	1.5 l TSI		MAHLE-6CVC140e with magnetic clutch	R1234yf		3Q0 816 803 B
EA288 TDI 2.0 l	2.0 l TDI	Cab and vehicle interior	DENSO- 6SES14 without magnetic clutch	R1234yf	140	5Q0 816 803 H
EA211 MPI 1.6 l EU 4 / EU 5	1.6 l MPI		MAHLE- 6CVC140c without magnetic clutch	R1234yf		5Q0 816 803 J
PHEV	—	Cab and vehicle interior	Hanon Gen3.8.4EU	R1234yf	27	5QE.816.803 H

If other air conditioning systems are to be retrofitted, the guidelines from the equipment manufacturer, and those for the system components, should be observed. The Converter is then solely responsible for operating and road safety.

Retrofitting or renewal of ancillaries such as the refrigerant compressor is only possible instead of the genuine refrigerant compressor in the main belt track. (see [chapters 2.7.1 “Compatibility with base vehicle”](#) and [2.7.4. “Specifications of genuine refrigerant compressor”](#))

2.7.3 Retrofit load compartment cooling system

Retrofitting or replacing ancillaries (for example, refrigerant compressor, pumps etc.) is only possible in place of the original component. For retrofit load compartment cooling, we recommend using the original refrigerant compressor (see table and [chapter 2.7.4 “Specifications of standard refrigerant compressor”](#)):

Engine designation	Refrigerant compressor type	Component no.	Weight [g]
EA288evo TDI 2.0 l	DENSO 6SAS14	3Q0 816 803 D	5,130
EA211evo TSI 1.5 l EU 6 Plus	MAHLE 6CVC140e	3Q0 816 803 B	5,365
EA288 TDI 2.0 l	DENSO 6SES14	5Q0 816 803 H	4,360
EA211 MPI 1.6 l EU 4 / EU 5	MAHLE 6CVC140c	5Q0 816 803 J	4,418
PHEV	Hanon Gen3.8.4EU	5QE.816.803 H	5,976

If other refrigerant compressors are to be fitted, the guidelines from the equipment manufacturer and for the system components should be observed. The Converter is then solely responsible for the operating and road safety of the refrigerant compressor and the air-conditioning system.

Compatibility with the base vehicle must be observed without fail (see [chapters 2.7.1 “Compatibility with base vehicle”](#) and [2.7.4 “Specifications of genuine refrigerant compressor”](#)).

Practical note

In vehicles without an air conditioning system, please note that it is necessary to recode the engine/motor control unit when an ancillary is retrofitted.

2.7.4. Specifications of genuine refrigerant compressor

2.7.4.1 Maximum cooling output

Engine designation	Refrigerant compressor type	Component no.	Output "L" [kW]*	Cooling output "Q" [kW]*
EA288evo TDI 2.0 l	DENSO 6SAS14	3Q0 816 803 D	2.7*	5.3*
EA211evo TSI 1.5 l EU 6 Plus	MAHLE 6CVC140e	3Q0 816 803 B	2.9*	5.3*
EA288 TDI 2.0 l	DENSO 6SES14	5Q0 816 803 H	2.7*	5.3*
EA211 MPI 1.6 l EU 4 / EU 5	MAHLE 6CVC140c	5Q0 816 803 J	2.9*	5.3*
PHEV	Hanon Gen 3.8.4EU	5QE.816.803 H	1.8**	3.6**

*) Figures on refrigerant compressor with high pressure Pd=16 bar, suction pressure Ps=2.8 bar and speed N=2000 rpm, refrigerant R134a

**) Figures on refrigerant compressor with high pressure Pd=15 bar, suction pressure Ps=3.0 bar and speed N=5,000 rpm, refrigerant R134a

2.7.4.2 Weight of the refrigerant compressor

Engine designation	Refrigerant compressor type	Component no.	Weight [g]
EA288evo TDI 2.0 l	DENSO 6SAS14	3Q0 816 803 D	5,130
EA211evo TSI 1.5 l EU 6 Plus	MAHLE 6CVC140e	3Q0 816 803 B	5,365
EA288 TDI 2.0 l	DENSO 6SES14	5Q0 816 803 H	4,360
EA211 MPI 1.6 l EU 4 / EU 5	MAHLE 6CVC140c	5Q0 816 803 J	4,418
PHEV	Hanon Gen3.8.4EU	5QE.816.803 H	5,976

2.7.4.3 Pulley diameter of the refrigerant compressor

Engine designation	Refrigerant compressor type	Pulley diameter d [mm]	Diameter of crankshaft drive wheel [mm]	Transmission ratio "i" (Crankshaft/air conditioner compressor)
EA288evo TDI 2.0 l	DENSO 6SAS14	Ø110	TDI Ø143 TSI Ø130	TDI 1.3 TSI 1.18
EA211evo TSI 1.5 l EU 6 Plus	MAHLE 6CVC140e	Ø110	TDI Ø143 TSI Ø130	TDI 1.3 TSI 1.18
EA288 TDI 2.0 l	DENSO 6SES14	Ø110	TDI/MPI Ø138	TDI/MPI 1.25
EA211 MPI 1.6 l EU 4 / EU 5	MAHLE 6CVC140c	Ø110	TDI/MPI Ø138	TDI/MPI 1.25
PHEV	Hanon Gen3.8.4EU	*	*	*

* No belt, electrical compressor

2.7.4.4 Specification of the poly V-belt

Engine designation		Refrigerant compressor type	Belt specification	Part no.
EA288evo TDI 2.0 l	2.0 l TD	DENSO 6SAS14	6PK1031	04L 260 849 G
		MAHLE 6CVC140e		04L 206 849 M
EA211evo TSI 1.5 l EU 6 Plus	1.5 l TSI	DENSO 6SAS14	6PK1005	04E 145 933 A1
		MAHLE 6CVC140e		
EA288 TDI 2.0 l	2.0 l TDI	DENSO 6SES14	6PK1033	04L 260 849 S
		MAHLE 6CVC140c	6PK1033	04L 260 849 S
EA211 MPI 1.6 l EU 4 / EU 5	1.6 l MPI	DENSO 6SES14	6PKD1000	04E 145 933 A
		MAHLE 6CVC140c	6PKD1000	04E 145 933 L
PHEV	-	Hanon Gen3.8.4EU	*	*

* No belt, electrical compressor

2.7.4.5 Connection dimensions of genuine refrigerant compressor

Information

The exterior and connection dimensions of the ancillaries can be found in the manufacturer's data sheets.

2.8 Add-ons/units

2.8.1 Roof carriers

Roof loads raise the centre of gravity of the vehicle and lead to a high dynamic axle load shift. Also, there is greater body lean when driving on rough roads and when cornering. The vehicle handling is significantly impaired.

For this reason, roof loads should be avoided if at all possible.

The fixed points on the roof should be used for attaching racks. For vehicles with a roof railing, carry bars must only be positioned in the marked areas. The assembly instructions of the carrier manufacturer must be observed.

At least 2 base carriers are required.

There are 3 mounting points in the roof on each side on the Caddy as standard (see Fig. 1).

There are 4 mounting points in the roof on each side on the Caddy Maxi as standard (see Fig. 2).

Various roof carriers are available ex-works as special equipment.

For more information, refer to the sales documents of Volkswagen AG.

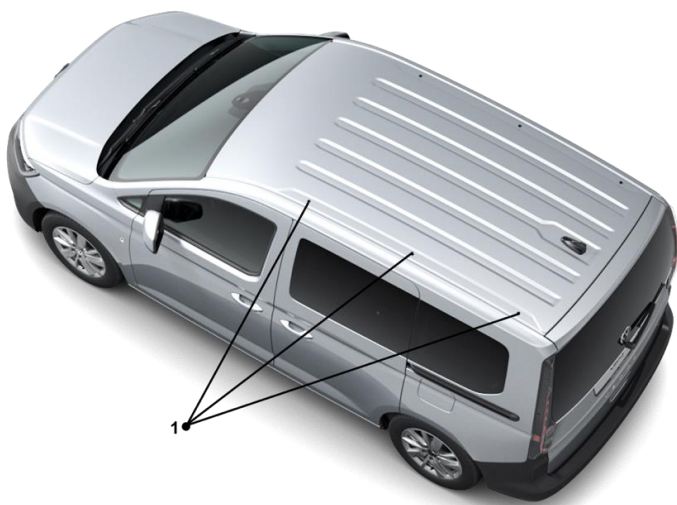

Fig. 1: Caddy mounting points



Fig. 2 Caddy Maxi mounting points

On request, Converters can be provided with drawings and CAD data. Please contact us before starting your conversion (see [chapter 1.2.1. "Product and vehicle information for Converters"](#)).

2.8.2 Rear luggage carrier/rear ladders

The rear member must be configured so that no static or dynamic loads are exerted on the bumpers after it has been fitted.

2.8.3 Towing brackets

Only the equipment tested by the manufacturer and approved for the vehicle model may be used as towing brackets.

2.8.3.1 Maximum trailer weights

Caddy

Vehicle type	Motor type	Braked [kg]	Unbraked [kg]
Caddy Cargo	By engine/gearbox combination	1,100–1,500	750
Caddy	By engine/gearbox combination	1,100–1,500	750

with 12% gradeability depending on engine.

Caddy Maxi

Vehicle type	Motor type	Braked [kg]	Unbraked [kg]
Caddy Cargo	By engine/gearbox combination	1,100–1,500	750
Caddy	By engine/gearbox combination	1,100–1,500	750

with 12% gradeability depending on engine.

The maximum permitted draw bar load is 75 kg for the Caddy Cargo and Caddy.

The max. permitted gross combination weight specified in the papers must not be exceeded. The actual weight of the trailer weight is not allowed to exceed the permitted gross weight of the towing vehicle.

2.8.3.2 Retrofitting a trailer towing bracket

When retrofitting a towing bracket, the regulations of the respective country and UN-R 55 in its most up-to-date version must be observed. The vehicle shall be presented to a motor vehicle test centre with responsibility for this matter.

2.8.3.3 Clearance according to UN-R 55

When fitting a ball coupling in the EU, the installation dimensions and clearances specified in UN-R 55 must be observed.

Any other applicable national regulations must be taken into account.

When the vehicle is loaded with the permitted total mass, the middle of the coupling ball is permitted to hang between 350 mm and 420 mm above the road surface. This applies to vehicles with a permitted total mass $\leq 3,500$ kg. Off-road vehicles are excepted. Unspecified details shall be selected in a reasonable manner.

The test of dimensions and angles shall be undertaken with suitable length and/or angle measuring instruments.

Ball hitch

The specified clearances shall be observed.

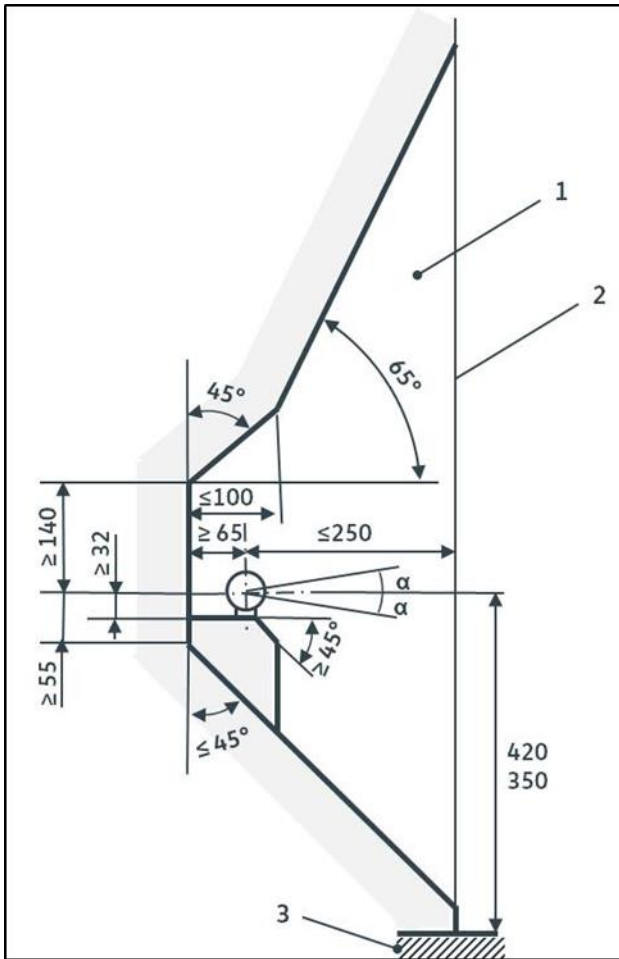

Clearance according to the height of the coupling ball as per UN-R 55 (side view)

- 1 – Clearance
- 2 – Vertical plane through end points of the total length of the vehicle
- 3 – Floor

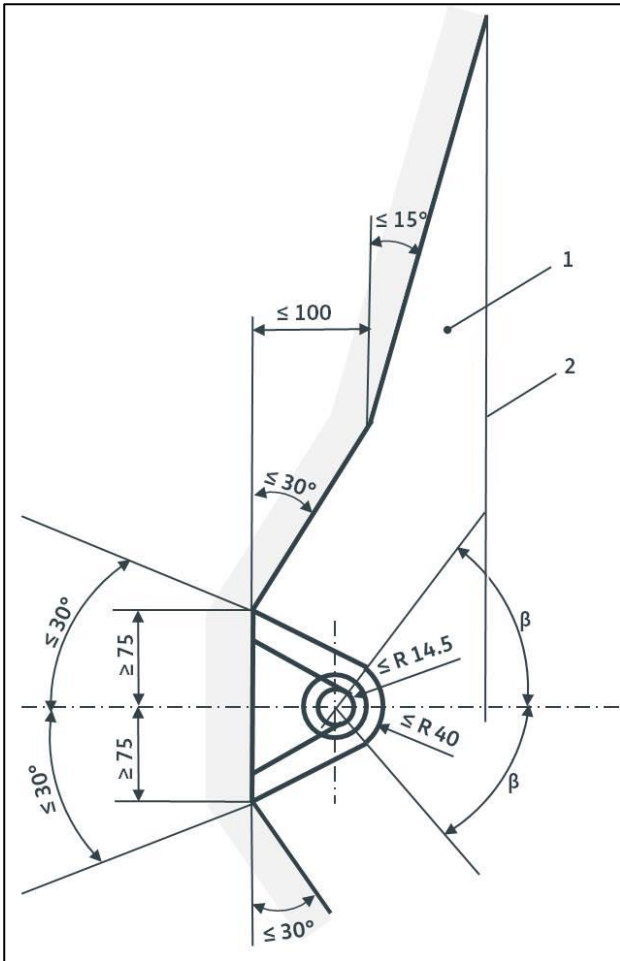

Clearance of the coupling ball according to UN-R 55 (top view)

1 – Clearance

2 – Vertical plane through end points of the total length of the vehicle

2.9 Raising the vehicle

1. With lifting platforms

The vehicle is only allowed to be raised at the lifting points provided. Refer to the corresponding repair manual for information about the lifting points.

2. With a jack

See the owner's manual for the procedure and jacking points on all vehicle variants.

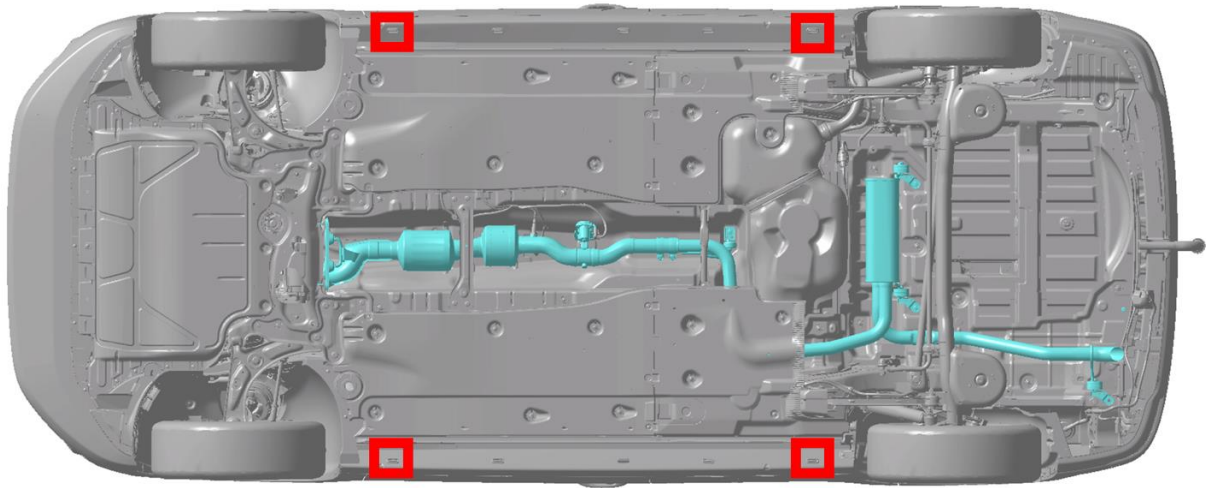

Fig. 1: Positions for jack (schematic diagram)

3 Modifications to closed bodies

3.1 Body-in-white/body

Comply with the following instructions with regard to mounting bodies and making conversions on the vehicle:

Changes to the body are not allowed to impair the function and strength of power units and operating devices of the vehicle, neither may they reduce the strength of weight-bearing parts.

During vehicle conversions and installation of bodies, it is not permitted to make any modifications which impair the function and freedom of movement of the suspension (e.g. for maintenance and inspection work) or the accessibility to the same. Interventions in the cross-member structure from the front end to the rear of the B-pillar are not allowed.

Modifications in the roof area and on the rear gate are not allowed.

The clearance for the fuel filler neck as well as for the fuel tank lines and fuel lines shall be maintained.

Avoid corners with sharp edges. The standard tank cap must not be removed or covered with a part that forms a block.

Neither drilling nor welding is permitted on the A and B-pillars.

If cutting is performed on the C and D-pillars (rear gate), including the corresponding roof cross struts, then rigidity shall be restored by means of additional components. The gross axle weight ratings must not be exceeded.

Holes in the frame longitudinal member are the result of the production process and are not suitable for attaching add-ons, bodies, installations and conversions; otherwise, the frame may be damaged.

3.1.1 Side wall cut-outs

The body and underbody form a self-supporting unit. Weight-bearing parts of this self-supporting unit

may not be removed without replacement. On the Caddy Cargo, the body and underbody form a self-supporting unit.

Windows, roof hatches and breather and ventilation openings must be surrounded by a stable frame.

This frame shall be connected to other body elements by means of a force-locking connection.

Warning note

It is not permitted for the outer roof frame to be machined on vehicles with side head airbags!

Information

For further information about body assembly work, refer to the Internet under erWin (Electronic Repair and Workshop Information of Volkswagen AG):

<http://erwin.volkswagen.de/erwin/showHome.do>

*Information system from Volkswagen AG, subject to payment

3.1.2 Subsequent installation of windows

Retrofitting windows is complicated and costly. Therefore Volkswagen Commercial Vehicles recommends ordering the required windows ex-works.

If windows are to be retrofitted, proceed in accordance with the Workshop Manual for Caddy 2011> (body assembly instructions, exterior, section 64 – Glazing/subsection 5.10 Side window, sliding door, Caddy Cargo, postal and courier vehicles).

Information

For detailed instructions about the installation and removal of windows, refer to the workshop manuals of Volkswagen AG on the Internet under erWin* (Electronic Repair and Workshop Information of Volkswagen AG):

<http://erwin.volkswagen.de/erwin/showHome.do>

*Information system from Volkswagen AG, subject to payment

Comply with the following points if smaller windows are to be installed:

The cut-out must only be made between the pillars, the roof frame and the sill.

No weight-bearing parts are allowed to be cut into or weakened.

The cut-out must be fitted with a continuous frame which has a force-locking connection to the adjacent weight-bearing parts.

3.1.3 Roof cut-outs

Roof cut-outs are only possible between the roof bows and the side roof frames. For details, see Figs. 1 and 2 below.

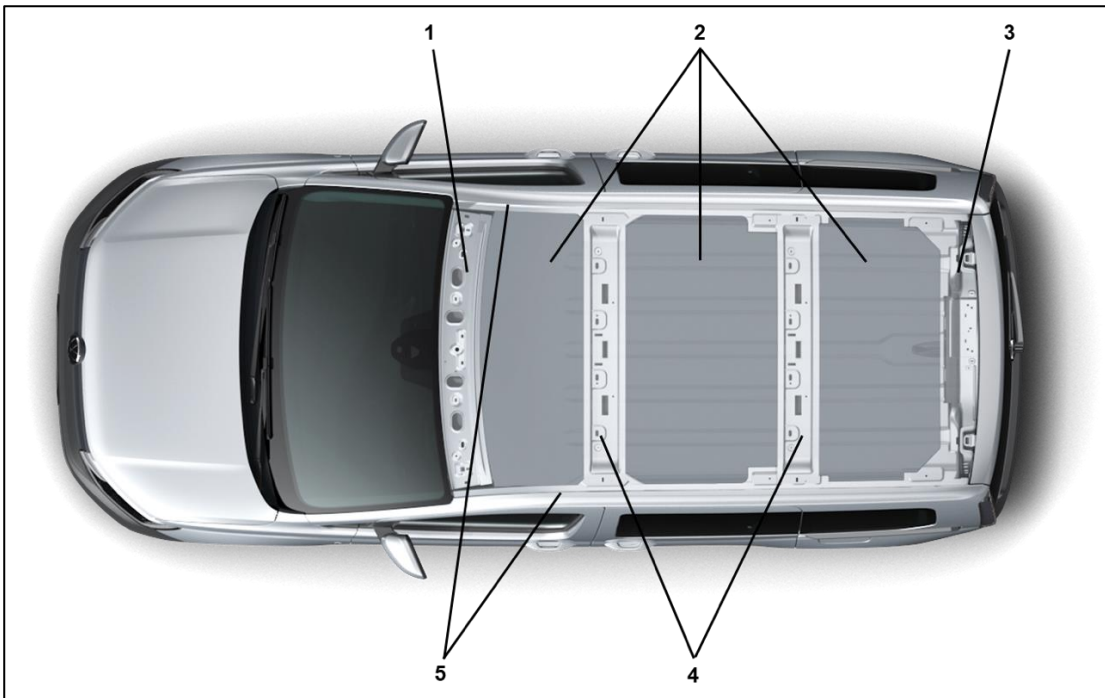

Fig. 1: Caddy

- 1 – Front roof frame
- 2 – Areas for roof cut-outs
- 3 – Rear roof frame
- 4 – Roof cross strut
- 5 – Roof frame right/left

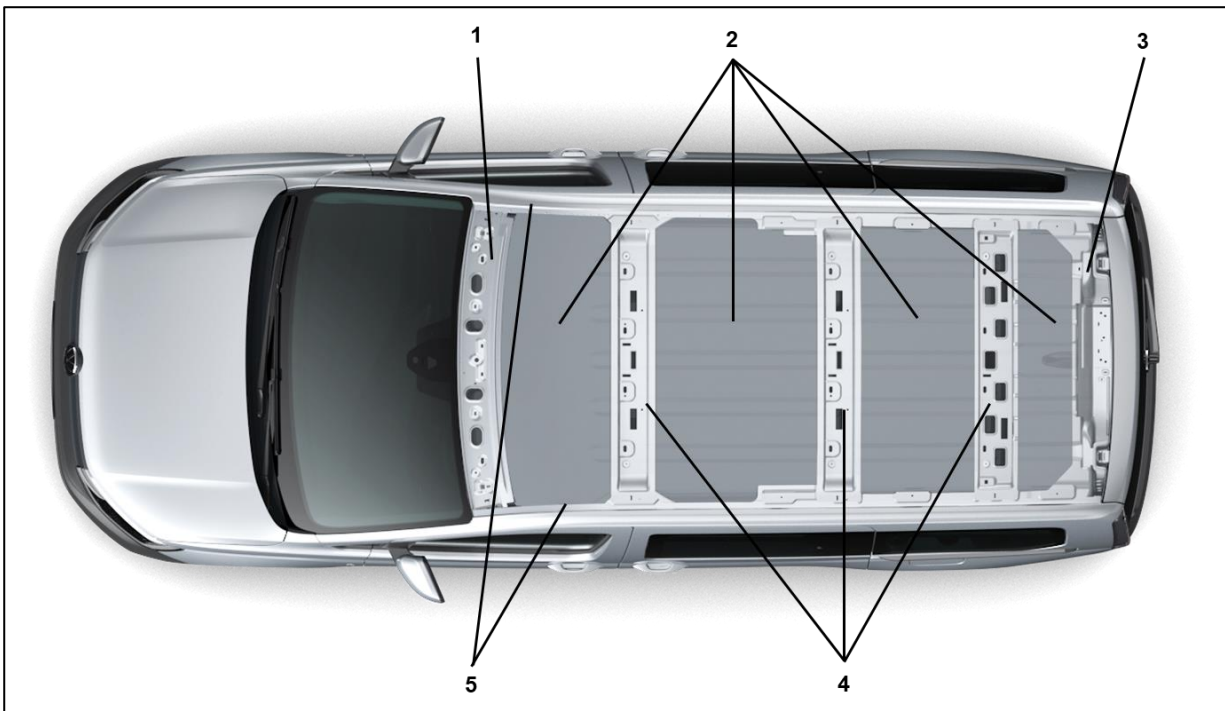

Fig. 2: Caddy Maxi

- 1 – Front roof frame
- 2 – Areas for roof cut-outs
- 3 – Rear roof frame
- 4 – Roof cross strut
- 5 – Roof frame right/left

Practical note

The roof cut-out must be provided with an all-round frame having a force-locking connection with the adjacent weight-bearing parts (cross strut and windscreen frame).

Information

For further information about body assembly work, refer to the Internet under erWin (Electronic Repair and Workshop Information of Volkswagen AG):

<http://erwin.volkswagen.de/erwin/showHome.do>

*Information system from Volkswagen AG, subject to payment

3.1.4 Modifications to the roof of the Caddy Cargo / Caddy

The following points shall be observed if modifications are made to the roof structure of a Caddy Cargo/Caddy:

- The all-round concept shall be retained, and adequate replacement rigidity shall be guaranteed
- Impairments to the function of the rain/light sensor shall be avoided
- Attachments similar to the roof carrier are possible for subsequent attachment of add-ons
- The vehicle constraints (strength, overall vehicle dimensions, registration etc.) shall be considered with regard to attachments on the roof panel
- The replacement rigidity of the new roof structure shall correspond to that of the standard roof
- Following all conversion and installation work on the vehicle, surface and corrosion protection shall be applied to the affected points

Information

For further information about body assembly work, refer to the Internet under erWin (Electronic Repair and Workshop Information of Volkswagen AG):
<http://erwin.volkswagen.de/erwin/showHome.do>

*Information system from Volkswagen AG, subject to payment

3.1.5 Modifying the partition wall/forced ventilation

Partition walls do not have any weight-bearing function. Partitions in the Caddy Cargo can be complete or partial.

The following partitions are available ex works as special equipment for the Caddy Cargo:

PR no.	Description
3CA	Without partition (preparation for partition)*
3CF	Partition wall without window*
3CG	Partition with fixed window*
5WC	Partition wall with grille*

* With N1 approval



Schematic diagram / panel van without partition

When ordering/purchasing a Caddy Cargo ex works without partition (3CA), please note:

- The vehicle is incomplete and has the factory label 1EV (EC certification as N1 commercial vehicle) and also SET: AFZ (COC paper as incomplete vehicle**)

Information

** In the EU, individual certification is required.

For further approval options, please contact your importer or technical service.

When installing non-factory partitions, make sure that the vehicle body is not completely sealed off. It must be ensured that air can flow between the driver's compartment and the load compartment.

You can obtain more information on special equipment depending on the vehicle model from your Volkswagen customer service and from the website.

This is important in several respects:

- Closing comfort of the doors
- Possible flow rate of the heating blower
- Pressure equalisation on airbag deployment

The installed partition should have a factory label for clear identification.

If the partition is located behind the first seat row (driver's compartment), bear the possible seat adjustment range in mind.

If the partition is located behind the 1st seat row (driver's compartment), the standard bolt-on points should be used if possible. (See [chapter 3.1.6 "Partition connection points"](#)).

Please note that some equipment variants of the Caddy can be equipped as standard with side head-protection airbags for the driver, front passenger and for the rear passengers of the second and third seat rows. Please refer to the owner's manual for a view of the deployment zones of the airbags.

With regard to acoustic comfort, the partition should be adequately stable and have a noise insulating effect.

When retrofitting a partition, make sure that the specification corresponds to the partition wall of the vehicle registration as a passenger car (M1) or Caddy Cargo (N1). The Converter is responsible for ensuring that the partition complies with the applicable regulations in the countries of registration and, where necessary, the specifications of professional associations and regulations of the country in which the vehicle is marketed.

Warning note

In vehicles with side head-protection airbags on the roof side member, no add-ons or modifications can be carried out in the area of deployment of the airbags (e. g. dividing walls).

The series-production position of the elements may not be changed. Otherwise, the passengers on the outer seats are no longer protected in the event of a side impact.

You will find further information on the standard contact points as well as assembling and removing the standard partition in the Volkswagen AG Workshop Manuals.

Information

Volkswagen AG Workshop Manuals and workshop information can be downloaded from the internet at **erWin*** (electronic repair and **W**orkshop **i**nformation from Volkswagen AG):

<http://erwin.volkswagen.de/erwin/showHome.do>

*Information system from Volkswagen AG, subject to payment

3.1.6 Partition connection points

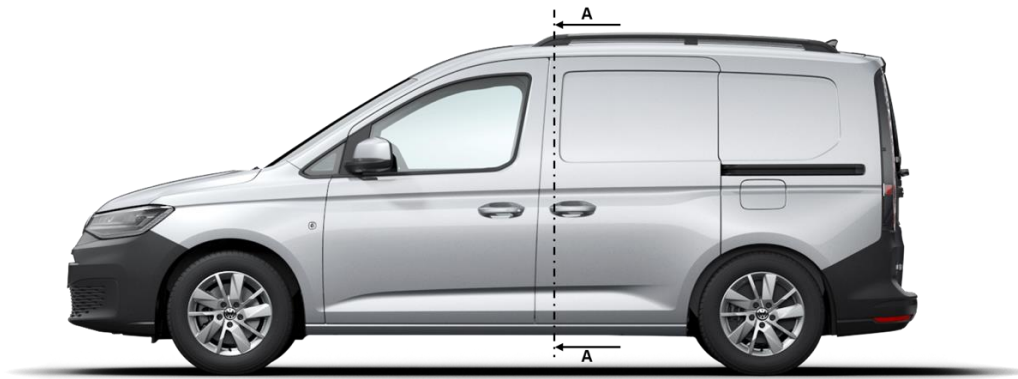

Fig. 1: Series partition (section A-A)

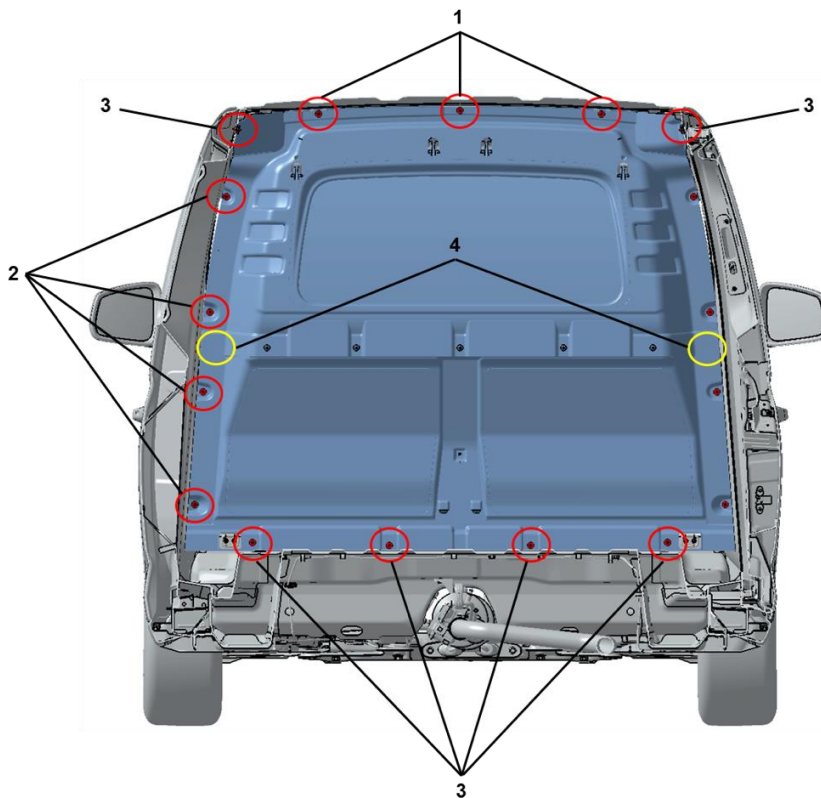

Fig. 2: Mounting points for the standard partition (section A-A)

Mounting points on the vehicle for the standard partition:

- 1 – 3x M6 pop rivet nut
- 2 – Side panel, on left and right: 4x speed nuts M6x23.8x16 mm
- 3 – 6x M6 round weld nuts
- 4 – 2x speed nuts M6x23.8x16 mm

Installation sequence:

- Partition bracket
- Partition bottom part
- Partition top part

3.2 Interior

The following points shall be observed without fail for conversions:

- The driver and front passenger airbag units, the airbags and the belt tensioners are pyrotechnical objects. Their handling, transport and storage are subject to legislation on potentially explosive substances, and the responsible public authority or government agency shall therefore be notified. Purchase, transport, storage, installation and removal as well as disposal are only allowed to be performed by trained staff in accordance with the corresponding safety regulations
- Modifications in the cockpit area and above the shoulder line must meet the criteria of the head impact tests according to UN-R21. This applies in particular to the deployment zones of airbags (wooden trim, additional installations, mobile telephone retainers, bottle holders etc.)
- Painting or surface treatment of the dash panel, steering wheel impact absorber and the tear seams of the airbags is not permitted
- The permitted centre of gravity position and axle loads are not allowed to be exceeded
- The interior fitting-out shall be configured with soft edges and surfaces
- Installations shall be manufactured from flame-retardant materials, and be firmly installed
- Unhindered access to the seats shall be guaranteed
- No projecting parts, corners or edges that could cause injuries are allowed to be located in the area of the seats

3.2.1 Safety features

Warning note

In case of interventions by the Converter in the structure of the vehicle, such as

- Modifications to the seats and consequently altered kinematics of the occupants in case of a crash
- modifications to the front body
- installations of parts in the vicinity of the exit openings and the deployment range of the airbags. (see owner's manual of the vehicle)
- Installation of third-party seats
- Modifications to the doors

the safe function of the front airbag, side airbag and belt tensioners is no longer guaranteed. This could result in personal injuries.

Vehicle components that cause vibration must not be assembled near the airbag control unit or the sensors.

Modifications to the floor structure in the area of the airbag control unit or the satellite sensors are also unauthorised. For information about the deployment zones of the airbags, refer to the Owner's Manual of the vehicle.

3.2.2 eCall Emergency System

In the event of an accident, the EU eCall Emergency Call Service can help to reduce the time it takes until emergency services arrive at the scene. Data is transmitted to the emergency response coordination centre via the OCU communication model.

The emergency call therefore does not depend on a mobile telephone being ready for operation, but does require a mobile phone connection and the possibility of locating the vehicle via GPS or Galileo. It is automatically triggered by the crash sensors or manually by the driver using the SOS button. The emergency call automatically goes to the nearest emergency response coordination centre.

General conditions:

The ecall Emergency System consists of the following components:

- Communication module (OCU)
- Emergency call button
- Microphone
- Emergency call loudspeaker
- Aerials for mobile network
- Global satellite navigation system
- and their connections and cables.

As this is a certified system, no changes to components of the ecall Emergency System are permitted.

It should also be ensured in particular that the acoustic properties of the ecall Emergency System system (emergency call loudspeakers and microphone) are not

changed by alterations to the vehicle construction. By retrofitting or removing a partition, for example. Should you have any more questions, please contact us (see [chapter 1.2.1 "Product and vehicle information for Converters"](#)).

Information

The ecall Emergency System comes as standard with the Caddy 5.

3.2.3 Seat retrofitting / seating with standard seats

Retrofitting seats with standard seats in the 3rd seat row is only possible in the Caddy if the seat preparation with PR no. 3NR was taken into account when ordering the vehicle.

Please refer to [chapter 1.3.1 "Selection of the base vehicle"](#) in this regard.

3.3 Add-ons

3.3.1 Accessories

An extensive range of accessories for the Caddy/Caddy Maxi can be obtained from Volkswagen Accessories.

Information

For more information about this topic, refer to:

<http://www.volkswagen-zubehoer.de/>

4 Implementations of special bodies

4.1 Motor vehicles for the transport of persons with disabilities (KMP)

A wide range of driving aids for disabled persons, catering to persons with various disabilities, is available as optional equipment from Volkswagen AG. For more information, please contact your Volkswagen dealership.

Information

For more information about this topic, refer to:

<https://www.volkswagen-nutzfahrzeuge.de/de/fahrzeugkauf/umbauten-und-individualisierung/menschen-mit-behinderung.html>

4.1.1 Basic vehicle equipment

When planning the special vehicle, select the equipment of the base vehicle according to the requirements of the future application (see also [chapter 1.3.1 “Selecting the base vehicle”](#)).

Please note that certain conversions are only allowed to be used by people with corresponding entries in their driving licence.

You can optimise your base vehicle for the conversion in advance by selecting the following special equipment items:

- Up-rated battery and alternator
- Sector-specific preparations

Practical note

Permanently installed components increase the kerb weight of the vehicle. As a result, the suspension compression height on the rear axle is reduced accordingly. If the additional installation solution weighs more than 180 kg, we recommend converting a specially coordinated spring pack (PR number UC5). See also [chapter 2.2.7.1 “Rear axle running gear for heavy installations”](#).

Warning note

Please bear in mind that if the permanently installed components are removed then the spring pack, PR number UC5, must be replaced by standard equipment. Otherwise, the driving properties might be negatively impaired.

For more information, please contact your Volkswagen dealership.

4.1.2 Selection of steering rack for conversions for people with disabilities

In the Caddy, Volkswagen offers you power steering with mobility aid (PR no. 1N5) as special equipment.

The power steering is given a lower steering torque by setting a different mobility characteristic. This has an effect at relatively slow driving speeds (parking, urban driving) in particular.

4.1.3 Notes on conversion solutions for the wheelchair transporter

- Ensure sufficient clearance between the running gear parts and the body, even when driving on a rough roads with gross vehicle weight rating and permitted rear axle load
- If the routing of the exhaust system is modified or if sections of the pipe are cut out, it must be ensured that clearances to other components are adequate even when the exhaust system expands at operating temperature, and that touching is avoided
- As a rule, the general certificate of roadworthiness of the whole vehicle will be invalidated if the exhaust system is modified. The wheelchair transporter is classified as a “special purpose” vehicle, which means the approval for the whole vehicle is retained. If a modified rear silencer is used, it is only necessary to provide verification of the noise level during “driving past at accelerated speed” for the vehicle
- If modifications are made to the exhaust system and the fuel system, it is necessary to ensure adequate protection of the surroundings by fitting heat shields
- If the rear end is converted in order to create a flat loading ramp for driving the wheelchair in easily, sufficient ground clearance in the rear area must be ensured in order that an adequate ramp angle can be achieved (e.g. ferry, multi-storey car park) with the permitted rear axle load
- Any PDC sensors must remain in their original position and function as in the production vehicle
- The securing bolts of the rear axle shock absorbers must still be accessible after installation to allow the shock absorbers to be removed

The new axle concept of the Caddy also offers the option of fitting the vehicle with a rear ramp. A rear axle kit (PR no. P4W) is offered ex-works for this. This creates space in which the lowerable ramp can be installed by moving the panhard rod and using a new stabiliser as well as other vibration dampers and coil springs. This rear axle kit cannot be combined with a towing bracket.

The Caddy (except for: 4Motion and CNG) can be retrofitted with the KMP* chassis kit without a preparation package (PR number P4W). Because this is a conversion/retrofit that is relevant to safety, a manufacturer’s declaration is required. The manufacturer’s certification highlights which components (incl. the part numbers for installation) are necessary for a conversion/retrofit. You can obtain this manufacturer’s declaration from your importer or Volkswagen Commercial Vehicles dealership by specifying the vehicle identification number. They will also help you with the ordering process.

Your importer or Volkswagen Commercial Vehicles dealership will then send your manufacturer’s declaration and the fully completed order form for retrofitting the KMP running gear to the NSC**.

Note:

Please note that the Converter must connect the panhard rod on the body to the track rod using a bracket of its own because the bracket (body component) cannot be ordered / is not available via the electronic parts catalogue***.

Practical note

If the driver does not leave the vehicle through the driver or passenger door, fault messages may occur after several driving cycles due to the safety concept. For this reason, Volkswagen recommends briefly opening and closing the driver door when leaving the vehicle after unbuckling to avoid fault entries.

Before using the vehicle, please familiarise yourself with all functions and special features of the vehicle by carefully reading the Owner's Manual. If you have any questions, please contact your Volkswagen authorised workshop.

Information

We will be happy to assist you with the design of the required bracket on the track rod. Send a technical request to:

customizedsolution@volkswagen.de

or via our free hotline:

00800 2878 66 49 33 (00800 customized)

Practical note

Please note that no special exhaust systems are offered ex works for conversions for persons with disabilities.

Modifications to the exhaust system may only be made after the exhaust gas treatment-relevant area within the scope of possible vehicle modifications for the transport of persons with impaired mobility for the country of registration (see [chapter 2.6.4 "Exhaust system"](#))

*KMP: motor vehicle for people with restricted mobility

** NSC: Commercial Vehicles service centre

*** ETKA: Electronic parts catalogue for After Sales

4.1.4 Notes on installing manual operating devices for the foot brake:

- Do not modify the brake pedal when installing manual operating devices. Select a clamped solution for connecting the manual operating device
- The operating travel of the manual operating device must also be sufficient for a blocking braking, with reserve travel for a circuit failure
- If a manual operating device is used for the accelerator and brake, the standard pedals must be covered by suitable means

4.1.5 Deactivating the airbag/belt tensioner system

The customer service workshop can also deactivate/reprogram the driver airbag/belt tensioner in exceptional cases – e.g. for drivers with a disability (with entry in the driving licence), if there is insufficient distance to the steering wheel or if a smaller steering wheel for wheelchair users is fitted (self-drive) and no airbag can be installed. For more information, please contact your Volkswagen customer service.

The following points must be observed when deactivating the airbag/belt tensioner:

1. The registration document for airbag/belt tensioner systems issued by authorised repairer must be stored in the vehicle wallet and handed over to the next owner on sale of the vehicle
2. A warning sticker indicating deactivation must be affixed to the dash panel in a clearly visible position and must not be removed until the airbag is reactivated
3. Alterations to/deactivations of functions (airbag, belt tensioner, seat-occupied sensor etc.) must be entered immediately in the vehicle documents (TÜV, DEKRA, responsible technical service)
4. Other users/purchasers of the vehicle must be informed that the specified safety systems have been deactivated and of the increased safety risk this entails
5. We strongly recommend that deactivated airbags/belt tensioner systems are reactivated by a authorised repairer before the vehicle is sold. This applies in particular if the vehicle is sold or permanently transferred to persons who do not fulfil the prerequisites for airbag deactivation

Practical note

Please note that permanently deactivating or removing the driver airbag also invalidates the belt unit type approval (belt tensioner, belt retractor). If an airbag is deactivated, the corresponding belt unit (for systems without airbags) must always also be adapted.

Follow the procedure for deactivating airbags specified in the workshop manual (see General body repairs, interior, repair group 1.8 Airbag deactivation and repair group 69 Passenger protection).

The workshop manual can be found online at erWin* (Electronic Repair and Workshop Information from Volkswagen AG):

<https://erwin.volkswagen.de/erwin/showHome.do>

*Information system from Volkswagen AG, subject to payment

Warning note

Deactivation means that the additional safety function of the airbag/belt tensioner is no longer ensured. Accidents may result in more severe injuries than those in which the airbag/belt tensioner is activated. Vehicle occupants have a greater risk of injury.

Special information for deactivating side airbags (replacing driver seat with disability seat):

1. In Germany, the second regulation (2.SprengV) of the Explosives Act (SprengG) applies to the storage and preservation of seats with side airbags. Customers who wish to store removed seats at their homes must first clarify the prerequisites for private storage with the responsible trade supervisory board
2. To store a removed seat, a safety plug must be fitted on the detached cables

Please also comply with the following chapters during your conversion:

- [1.3.1 "Selecting the base vehicle"](#)
- [2.2.1 "Permitted weights and kerb weights"](#)
- [2.3.2 "Modifications to the body-in-white"](#)
- [2.5.2.1 "Electrical wiring/fuses"](#)
- [2.5.2.3 "Retrofitting electrical devices"](#)
- [2.5.3 "Electrical interface for special vehicles"](#)
- [2.5.4 "Vehicle battery"](#)
- [2.5.5 "Retrofitting of alternators"](#)
- [3.1 "Body-in-white/Body"](#)
- [2.6.3 "Fuel system"](#)
- [2.6.4 "Exhaust system"](#)
- [3.2.1 "Safety features"](#)

4.2 Refrigerated vehicles

When planning the special vehicle, select the equipment of the base vehicle according to the requirements of the future application. (See also [chapter 1.3.1 “Selecting the base vehicle”](#)).

You can optimise your base vehicle for the conversion in advance by selecting the following special equipment items:

- Up-rated alternator
- Up-rated battery
- Use of the refrigerant compressor provided ex-works for the base vehicle

Notes on the Caddy Cargo:

- To facilitate repair, accessibility to the components of the door mechanism (e.g. guide rails and hinges) must be ensured
- Please note that the insulation in the Caddy Cargo increases the weight of the doors, and therefore also the load on the hinges, carriage and lock systems

Please also comply with the following chapters as part of the conversion:

- [1.3.1 “Selecting the base vehicle”](#)
- [2.2.1 “Permitted weights and kerb weights”](#)
- [2.3.2 “Modifications to the body-in-white”](#)
- [2.5.2.1 “Electrical wiring/fuses”](#)
- [2.5.2.3 “Retrofitting electrical devices”](#)
- [2.5.3 “Electrical interface for special vehicles”](#)
- [2.5.4 “Vehicle battery”](#)
- [2.5.5 “Retrofitting of alternators”](#)
- [2.7. “Engine auxiliary drives”](#)
- [3.1 “Body-in-white/Body”](#)
- [3.1.4 “Modifications to the roof of the Caddy Cargo/Caddy”](#)

4.3 Shelf installation/workshop vehicles

4.3.1 Shelf and workshop installations

For shelf and workshop installations, the following points must be observed:

1. Selection of a suitable base vehicle (gross vehicle weight rating, running gear, equipment)
2. Driver's compartment and load compartment should be separated by means of a retaining device (partition, load guard) according to DIN ISO 27956
3. The maximum permitted weights and axle loads of the base vehicle must be observed (see [chapters 2.2.1 "Permitted weights and unladen weights"](#) and [6.1 "Determining the centre of gravity"](#))
4. The installation should take place in a way that ensures that the forces induced are evenly distributed
5. The suitability of the available fastening rings should be checked before they are used to secure items
6. Assembly, maintenance and Owner's Manuals specifying the load limits should accompany the modified vehicle
7. The maximum load of drawers and shelves (taking dynamic forces into account) must be marked or indicated in the Owner's Manual. The Owner's Manual must be provided with the vehicle.
8. The vehicle structure must not be weakened by the installed components in the event of an accident.
9. The regulations and standards for load securing must be observed:
 - + DIN ISO 27956 (securing of cargo in delivery vans),
 - + VDI 2700 ff
 - + StVO or country-specific laws and regulations
10. The installation should be performed so as to be safe in the event of a crash (e.g. UNECE-R 44-3 City Crash):
 - + All items in the vehicle should be secured, installed or stowed in such a way that they cannot move in an uncontrolled manner in the event of acceleration/deceleration in a forwards, backwards, left, right or vertical direction
 - + All tested compartments, rails, installations intended for storage or storage equipment must be marked with the highest permitted weight loads
11. Edges that may come into contact with the hands, legs, head etc. of a vehicle occupant during normal operation must not have a radius of less than 2.5 mm
12. Following all work to the body, drilling chips should be removed and corrosion protection measures should be performed. (see [chapter 2.3.2 "Modifications to the body-in-white"](#))
13. The requirements of the Converter guidelines for electrical wiring and fuses must be observed:
14. [Chapter 2.5.2.1 "Electrical wiring/fuses"](#)
15. [Chapter 2.5.2.2 "Additional circuits"](#)
16. [Chapter 2.5.3 "Electrical interface for special vehicles"](#)
17. During installation and conversion no electrical wires or other components of the base vehicle (e.g. electrical wires fuel tank, brake lines etc.) must be damaged
18. Conversion should only be performed by trained specialist personnel
19. Ensure "sufficient ventilation" in vehicles intended for the transportation of gas cylinders. The so-called diagonal ventilation is deemed "sufficient". Usually from the front and above (roof) to the rear bottom (floor, side frame at bottom)

Warning note

All applicable safety regulations for handling gas cylinders must be complied with.

Practical note

Permanently installed components increase the kerb weight of the vehicle. As a result, the suspension compression height on the rear axle is reduced accordingly. If the additional installation solution weighs more than 180 kg, we recommend converting a specially coordinated spring pack (PR number UC5). See also [chapter 2.2.7.1 "Rear axle running gear for heavy installations"](#).

Warning note

Please bear in mind that if the permanently installed components are removed then the spring pack, PR number UC5, must be replaced by standard equipment. Otherwise, the driving properties might be negatively impaired.

4.4 Emergency vehicles

Please also comply with the following chapters as part of the conversion:

- [1.3.1 “Selecting the base vehicle”](#)
- [2.2.1 “Permitted weights and kerb weights”](#)
- [2.3.2 “Modifications to the body-in-white”](#)
- [2.5.2.1 “Electrical wiring/fuses”](#)
- [2.5.2.3 “Retrofitting electrical devices”](#)
- [2.5.3 “Electrical interface for special vehicles”](#)
- [2.5.4 “Vehicle battery”](#)
- [2.5.5 “Retrofitting of alternators”](#)
- [2.7 “Engine auxiliary drives”](#)
- [3.1 “Body-in-white/Body”](#)
- [3.1.4 “Modifications to the roof of the Caddy Cargo/Caddy”](#)
- [3.2.1 “Safety features”](#)

Practical note

Permanently installed components increase the kerb weight of the vehicle. As a result, the suspension compression height on the rear axle is reduced accordingly. If the additional installation solution weighs more than 180 kg, we recommend converting a specially coordinated spring pack (PR number UC5). See also [chapter 2.2.7.1 “Rear axle running gear for heavy installations”](#).

Warning note

Please bear in mind that if the permanently installed components are removed then the spring pack, PR number UC5, must be replaced by standard equipment. Otherwise, the driving properties might be negatively impaired.

Information

For more information on this topic, visit:
[http://www.Industry solutions and conversions | Volkswagen Commercial Vehicles \(volkswagen-nutzfahrzeuge.de\)](http://www.Industry solutions and conversions | Volkswagen Commercial Vehicles (volkswagen-nutzfahrzeuge.de))

4.5 Preparation for taxis and private hire cars

4.5.1 Preparation for taxis and private hire cars ex works

The following setups are available ex works with PR numbers:

- Taxi preparation (F4E)
- Private hire car preparation (F5P)

This includes the sub-functions:

- Taxi roof sign control system (only for taxi preparation PR number F4E)
- Emergency alarm control system for taxi and rental car
- Interior lighting control
- Connected power supply for two-way radios and peripherals
- Provision of data for the taximeter (e.g. output of a distance signal)

4.5.2 Pin assignment on CFCU* (input and output assignment / pins on CFCU*)

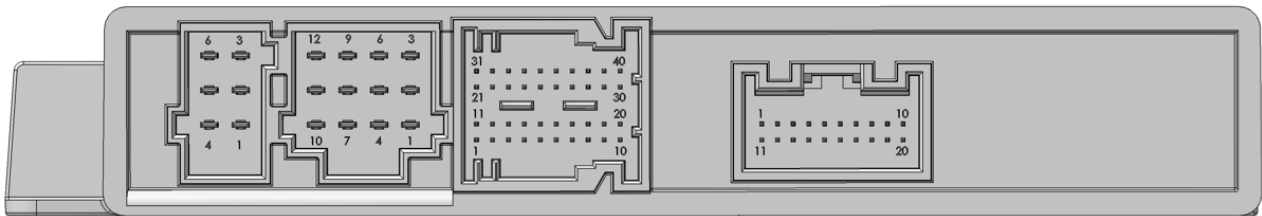

"KFG" view

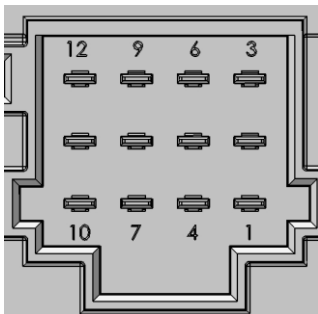

Plug 2

Plug 2				
Pin no.	12	9	6	3
Signal	MFA_2	MFA_19	MFA_1	MFA_6
Pin no.	11	8	5	2
Signal	MFA_21	MFA_20	MFA_4	MFA_5
Pin no.	10	7	4	1
Signal	MFA_22	MFA_3	MFA_8	MFA_7

CFCU pin assignment: taxis and private hire cars

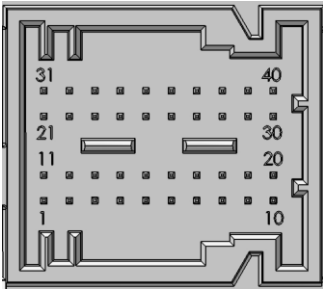

Plug 3

Plug 3										
Pin no.	31	32	33	34	35	36	37	38	39	40
Signal	MFA_9	MFA_10	MFE_10	MFE_12	MFE_14	MFE_16	MFE_2	MFE_4	MFE_6	MFE_8
Pin no.	21	22	23	24	25	26	27	28	29	30
Signal	MFA_11	MFA_12	MFE_9	MFE_11	MFE_13	MFE_15	MFE_1	MFE_3	MFE_5	MFE_7
Pin no.	11	12	13	14	15	16	17	18	19	20
Signal	MFA_17	MFA_18	MFA_14	Rel2_no	Rel2_com	REL2_nc	MFE_18	MFE_20	MFE_22	MFE_24
Pin no.	1	2	3	4	5	6	7	8	9	10
Signal	MFA_15	MFA_16	MFA_13	Rel1_no	Rel1_com	REL1_nc	MFE_17	MFE_19	MFE_21	MFE_23

CFCU pin assignment: taxis and private hire cars

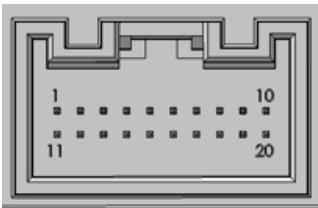

Plug 4

Plug 4										
Pin no.	1	2	3	4	5	6	7	8	9	10
Signal										
Pin no.	11	12	13	14	15	16	17	18	19	20
Signal	CAN_H:	CAN_L:								

CFCU pin assignment: Taxis and private hire cars

Inputs:

- MFE_01: Activation button for silent/passive alarm
- MFE_02: Activation button for loud alarm
- MFE_03: Deactivation button (emergency alarm)
- MFE_04: Activation button for the interior lighting
- MFE_05: Taxi roof sign button (only for taxi preparation PR number F4E)
- MFE_21: Signal from taximeter: Roof sign control (only for taxi preparation PR no. F4E)
- MFE_23: Signal from end device: fare

Outputs:

- MFA_01: Switched power supply (5 A) for the connection of peripheral devices/two-way radios
- MFA_04: Switched power supply (10 A) for the connection of peripheral devices/two-way radios
- MFA_10: Seat recognition signal (when the seat is occupied, except for the driver seat if the vehicle has seat recognition as standard)
- MFA_11: Taxi roof sign function feedback (active/inactive) (only for taxi preparation PR number F4E)
- MFA_12: Interior lighting function feedback (active / inactive)
- MFA_13: Loud or quiet alarm function feedback (active/inactive)
- MFA_14: Distance signal (1)
- MFA_19 / MFA_20: Connection for taxi roof sign
- MFA_21: Switched power supply (5 A) for connecting peripheral devices/two-way radios

(1) For stable and good signal quality, the additional use of a pull-up resistor is recommended (for example via an electrical connection to the MFE_06 input of the CFCU)

Information

Technical documentation on the CFCU and further information regarding the requesting and processing procedure can be found on the Customised Solution Portal via the link:

<https://www.customized-solution.com/de/de/technische-produktinformationen/kfg/technische-information>

You must register on the Customised Solution Portal in order to access this. The configuration of the customer-specific functional control unit (CFCU) can be ordered via the CS portal.

Information from the vehicle manufacturer on the conformity assessment can be obtained from your direct service partner or Converter support team (see [chapters 1.2.1.1 “Contact in Germany”](#) and [1.2.1.2 “International contact”](#)). You will also find information on this in the Owner’s Manual for your vehicle, on the Volkswagen Commercial Vehicles homepage under “Industry Solutions and Commercial Customers/Industry Solutions/Commercial Vehicles Passenger Transport/Taxi” or at your Volkswagen Commercial Vehicles Partner.

*CFCU: customer-specific functional control unit, see also [chapter 2.5.3.3](#)

4.5.3 Function description

Taxi roof sign (only for taxi preparation PR number F4E)

- MFE_05 for deactivating/activating the taxi roof sign (additional information on changing the automatic roof sign control and further information can be found in the owner’s manual for your vehicle).
- MFA_19 and MFA_20 activation (positive polarity)
- Activation of MFA_11 for feedback to driver in the roof sign button

Interior lighting

- The interior lighting is activated automatically while the fare is being paid (depending on the taximeter signal, reset when changing taximeter status to “free”)
- MFE_04 for activating/deactivating the interior lighting when the doors are closed
- Activation of MFA_12 for feedback to driver in the interior lighting button

Information

When leaving the vehicle with the vehicle key, the interior light is switched on after 30 minutes at the latest to reduce power consumption.

(When leaving the vehicle with the vehicle key, an activated roof sign is switched off after 30 minutes at the latest to reduce power consumption)

Emergency alarm (silent alarm)

- MFE_01 activates the silent alarm
- Activation of MFA_19 and MFA_20 for red warning LEDs in the taxi roof sign (this function depends on the design of the roof sign system)
- Activation of MFA_13 for feedback to driver in the loud alarm button

Emergency alarm (loud alarm)

- MFE_02 activates the loud alarm
- Activation of intermittent main beam
- Activation of hazard warning lights
- Activation of interior lighting
- Activation of intermittent vehicle horn
- Activation of MFA_19 and MFA_20 for red warning LEDs in the taxi roof sign (this function depends on the design of the roof sign system)
- Activation of MFA_13 for feedback to driver in the loud alarm button

Taxi alarm deactivation

- MFE_03 deactivates the taxi alarm (e.g. button installed in the engine compartment)

Voltage supply for taximeter and two-way radio

- MFA_01 Switched power supply (5 A) for connecting peripheral devices/two-way radio
- MFA_04 Switched power supply (10 A) for connecting peripheral devices/two-way radio
- MFA_21 Switched power supply (5 A) for connecting peripheral devices/two-way radio
- Time-controlled switching off the voltage supply and at low charge level of the battery

Provision of data for the taximeter

- Output of a distance signal via the MFA 14 output

4.5.4 Programming according to customer requirements

In addition, the programmable CFCU* provides an option for subsequently adjusting the configuration. (example: adding supplementary signals).

Information

Technical documentation on the CFCU and further information regarding the requesting and processing procedure can be found on the Customised Solution Portal via the link:

<https://www.customized-solution.com/de/de/technische-produktinformationen/kfg/technische-information>

You must register on the Customised Solution Portal in order to access this. The configuration of the customer-specific functional control unit (CFCU) can be ordered via the CS portal.

*CFCU: customer-specific functional control unit, see also [chapter 2.5.3.3](#)

4.6 Leisure vehicles

The new Caddy and Caddy Maxi can be ordered as leisure vehicles with the California equipment package directly ex works. For more information, please contact your Volkswagen dealership.

Please also comply with the following chapters as part of the conversion:

- 1.3.1 “Selecting the base vehicle”
- 2.2.1 “Permitted weights and kerb weights”
- 2.3.2 “Modifications to the body-in-white”
- 2.5.2.1 “Electrical wiring/fuses”
- 2.5.2.3 “Retrofitting electrical devices”
- 2.5.3 “Electrical interface for special vehicles”
- 2.5.4 “Vehicle battery”
- 2.5.5 “Retrofitting of alternators”
- 2.6.3 “Fuel system”
- 2.6.4 “Exhaust system”
- 3.2.1 “Safety features”

Practical note

Permanently installed components increase the kerb weight of the vehicle. As a result, the suspension compression height on the rear axle is reduced accordingly. If the additional installation solution weighs more than 180 kg, we recommend converting a specially coordinated spring pack (PR number UC5). See also [chapter 2.2.7.1 “Rear axle running gear for heavy installations”](#).

Warning note

Please bear in mind that if the permanently installed components are removed then the spring pack, PR number UC5, must be replaced by standard equipment. Otherwise, the driving properties might be negatively impaired.

Information

For more information about this topic, refer to the Volkswagen Commercial Vehicles website at:
<https://www.volkswagen-nutzfahrzeuge.de/de/modelle/nutzfahrzeugkategorien-im-ueberblick/california-reisemobile.html>

4.7 Vehicles for local and public authorities

Please also comply with the following chapters as part of the conversion:

- 1.3.1 “Selecting the base vehicle”
- 2.2.1 “Permitted weights and kerb weights”
- 2.3.2 “Modifications to the body-in-white”
- 2.5.2.1 “Electrical wiring/fuses”
- 2.5.2.3 “Retrofitting electrical devices”
- 2.5.3 “Electrical interface for special vehicles”
- 2.5.4 “Vehicle battery”
- 2.5.5 “Retrofitting of alternators”
- 3.2.1 “Safety features”

Information

Further information on this topic can be found on the Volkswagen Commercial Vehicles website at:
[http://www.Local and public authorities | Volkswagen Commercial Vehicles \(volkswagen-nutzfahrzeuge.de\)](http://www.Local and public authorities | Volkswagen Commercial Vehicles (volkswagen-nutzfahrzeuge.de))

4.8 Vehicles for couriers and logistics

Using vehicles for delivery services (e.g. post or parcel service) increases the load on the door arresters. To reduce the forces on the door arrester, we recommend ordering the version with additional buffer for the driver/front passenger door with the following PR number.

- OD2 Additional buffer on the driver and front passenger sides
- OD3 Additional buffer on the driver side

When there is a door arrester with an additional buffer, the opening angle of the doors is reduced by approx. 6 degrees! The third position is not reached!

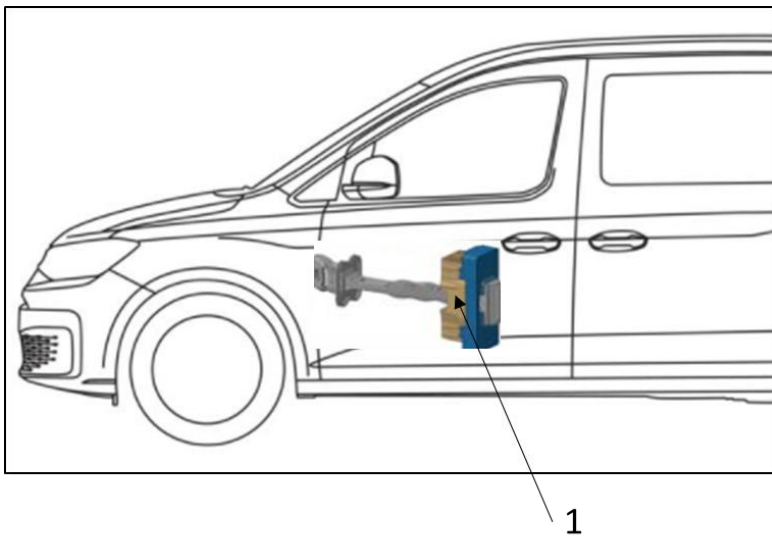

Fig. 1: Schematic diagram, door with buffered door arrester

1 – Additional buffer

4.9 Plug-in hybrid electric vehicle (PHEV)



4.9.1 High-voltage system

The high-voltage system consists of the following components:

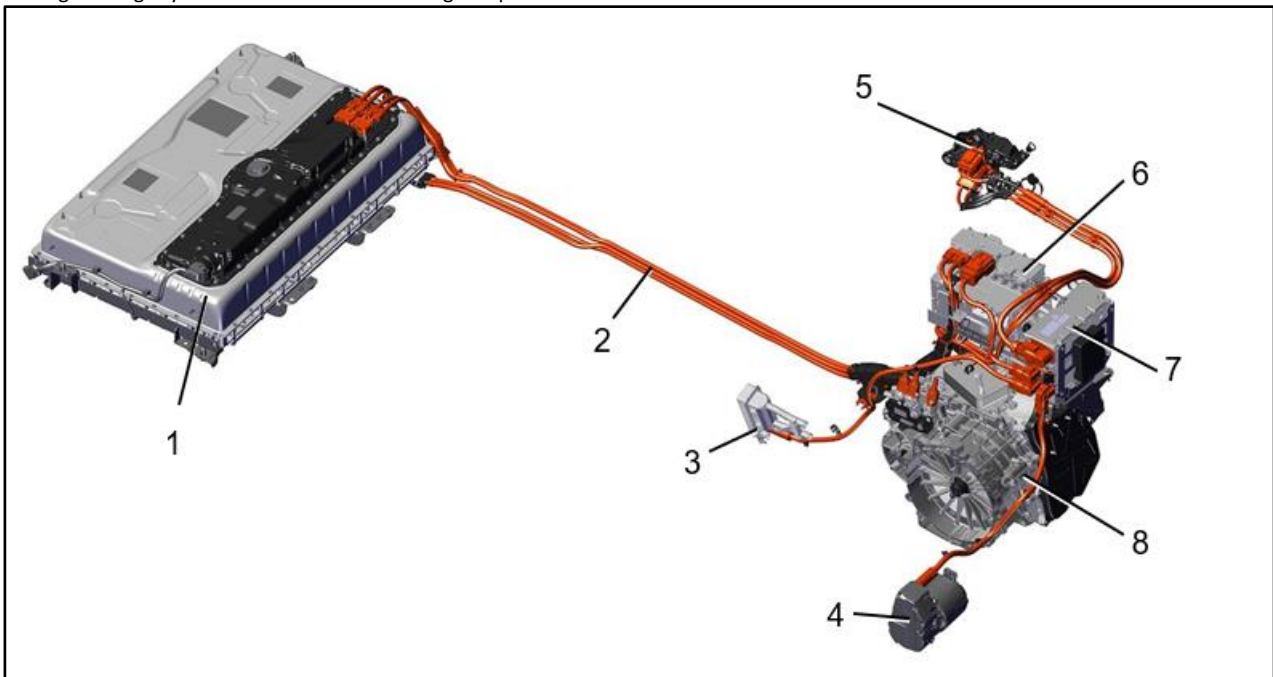

Fig. 1: The most important components of the electric drive

- 1 – High-voltage battery 1
- 2 – Orange-coloured high-voltage wires and connectors
- 3 – High-voltage heater (PTC)
- 4 – Electrical air conditioner compressor
- 5 – Charging socket 1 for high-voltage battery charging
- 6 – Power and control electronics for electric drive
- 7 – Charging unit 1 for high-voltage battery
- 8 – Three-phase current drive

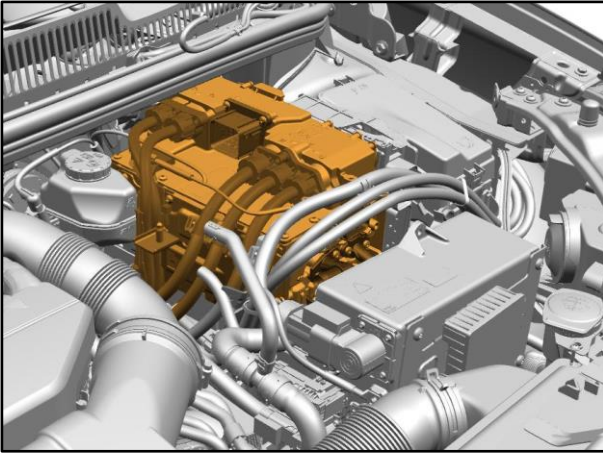

Fig. 2: Power and control electronics for electric drive

4.9.1.1 Power and control electronics for electric drive

The component is installed on the left side in the engine compartment.

It controls the three-phase current drive, charging of the 12-volt battery and the vehicle electrical system supply. Furthermore it forms the connection between the charging unit for high-voltage battery and the high-voltage battery. Cooling is performed via the low-temperature cooling circuit.

Practical note

All work carried out on the high-voltage system must be performed exclusively by a qualified workshop deploying suitably qualified and trained staff in accordance with Volkswagen's policies.

4.9.1.2 Modifications to the underbody area of the high-voltage battery and the drive

The components for the high-voltage battery system, including the assembly frame, crash elements and powertrain, must not be modified or reworked. No welding or processes that could produce sparks may be used in the underbody area, near the high-voltage components and the high-voltage battery.

The following work must be avoided in the underbody area:

- Work in the direct vicinity of the high-voltage components, high-voltage wires and high-voltage battery using cutting, deforming or sharp-edged tools.
- If drilling is necessary in the floor area, the greatest care is required. Before inserting the holes in the vehicle, check that no vehicle components, particularly high-voltage components, cables and wires are damaged.
- Fastenings on the vehicle floor that protrude into the area of the high-voltage battery or permanently restrict accessibility to the battery
- Exterior conversions that project into the area of the high-voltage battery or permanently restrict accessibility to the battery.

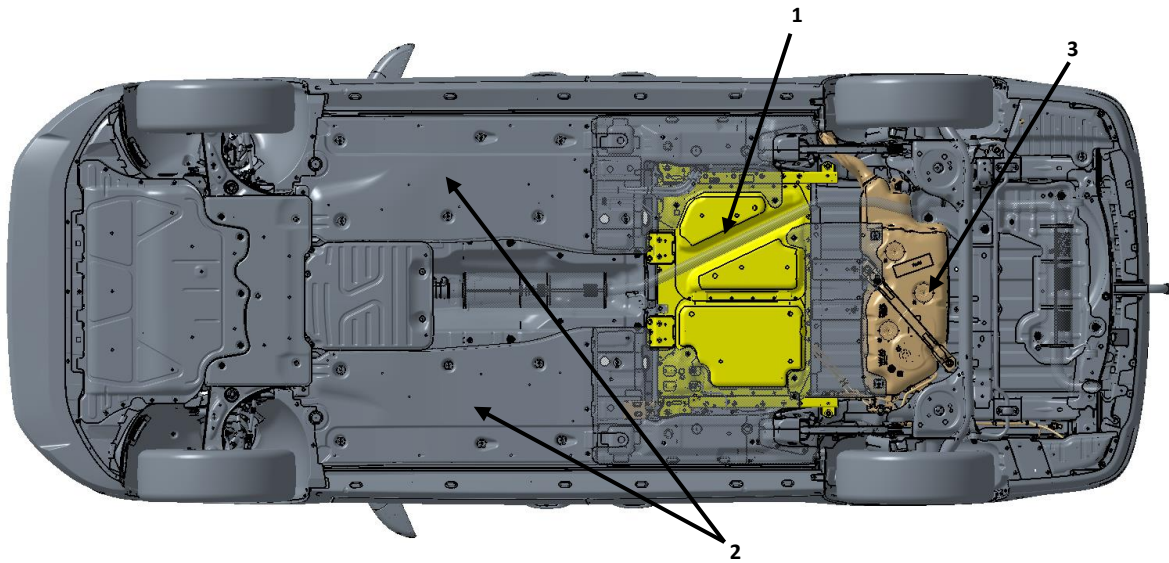

Fig. 1: Bottom view of high-voltage battery location, long wheelbase

- 1 – lithium-ion high-voltage battery
- 2 – underbody cladding
- 3 – Fuel tank

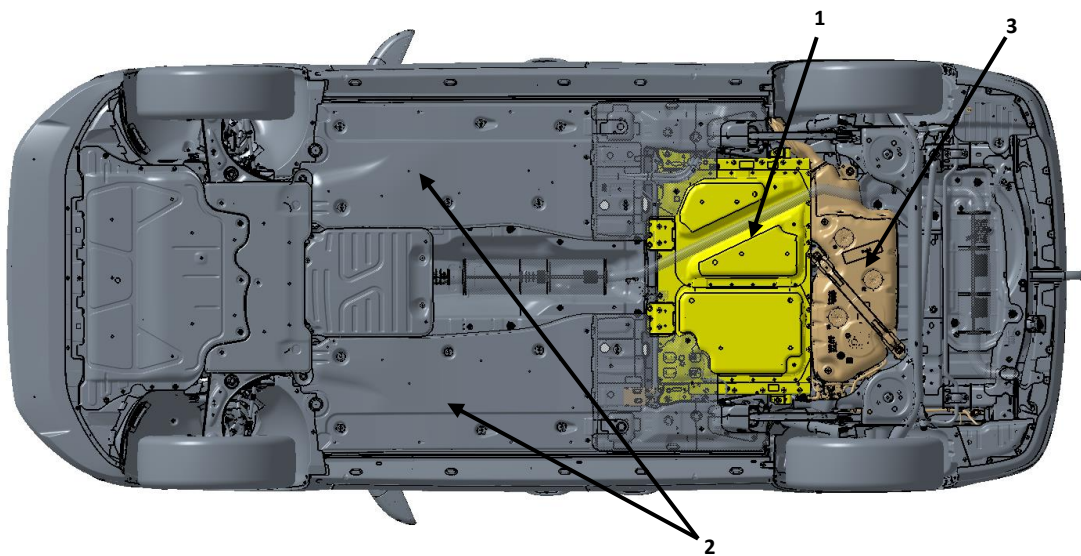

Fig. 2: Bottom view of high-voltage battery location, short wheelbase

- 1 – lithium-ion high-voltage battery
- 2 – underbody cladding
- 3 – Fuel tank

Practical note

Modifications to the electric drive system are not permitted. Solutions regarding engine speed control are not possible. Modifications to the cooling system (radiator, air intake, air ducts etc.) are not permitted. Cooling air inlet surfaces must be kept clear.

Warning note

Special safety notes must be observed when working on electric vehicles. Failure to observe safety notes can result in a fatal electric shock.

Information

The required safety notes can be requested. Please contact us (see [chapter 1.2.1 "Product and vehicle information for Converters"](#)).

Warning note

Modifications to the electrical drive system can lead to the system ceasing to function properly. Control of the vehicle may be lost.

Warning note

The voltage within the high-voltage vehicle electrics and high-voltage battery is life-threatening!

Touching damaged orange-coloured high-voltage wires and high-voltage battery may result in a fatal electric shock. The high-voltage system may also be active even if the ignition is switched off.

Never carry out any work on the high-voltage vehicle electrics, orange-coloured high-voltage wires, high-voltage components or high-voltage battery. Work on the high-voltage system may only be performed by qualified specialist companies with appropriate accreditation to perform such work.

Never modify, damage, dismantle or disconnect from the high-voltage system any of the orange-coloured high-voltage wires, high-voltage components or high-voltage battery.

Work in close proximity to high-voltage components, high-voltage wires or high-voltage battery using machining, deforming or sharp-edged tools or heat sources, such as welding, soldering, hot-air or thermal bonding, may only be carried out if the voltage has been disconnected beforehand. The high-voltage battery cannot be de-energised. The high-voltage disconnection may only be performed by suitably qualified and trained specialist staff.

If there is a fault in the high-voltage system, the drive is automatically deactivated where necessary, and a corresponding indicator may be displayed in the instrument cluster. Should this be the case, the drive will remain deactivated until the fault has been rectified by suitably qualified and trained specialist staff.

The various Volkswagen policies must be observed when carrying out any work on the high-voltage system, including in particular on the orange-coloured high-voltage wires, the high-voltage components or the high-voltage battery.

4.9.2 12-V vehicle electrical system

A DC-DC converter is installed in the PHEV instead of the three-phase alternator installed in diesel and petrol-driven vehicles to supply the 12-V electrical system. This converts the voltage from the high-voltage battery to 12 V so that the onboard supply battery is recharged. Due to the installation of the high-voltage components in the engine compartment, the 12-V onboard supply battery is installed on the right rear wheel arch in the PHEV. The installation of a stronger battery is not planned at the factory. There is also no option of a second battery preparation ex works.

The PHEV uses an electric air conditioning compressor. Changes to the compressor are unauthorised.

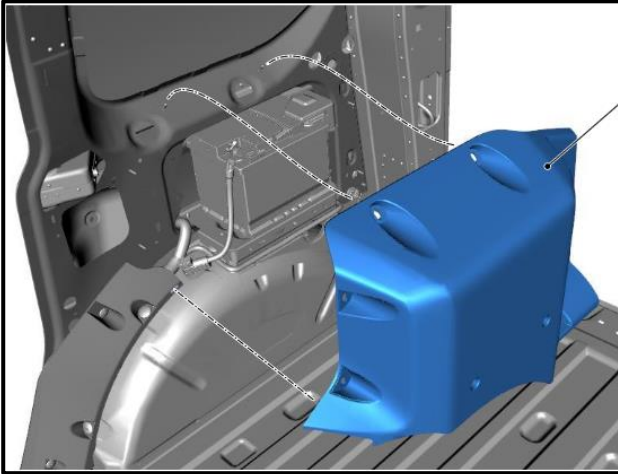

Fig. 1: Starter battery with cover in the rear right luggage compartment, above the wheel arch

A sound generator is mounted on the front right longitudinal member to generate driving noises during electric vehicle operation.

5 Technical data

5.1 Dimension drawings

Please refer to our build dimension drawings for the dimensions of the new Caddy and Caddy Maxi.

They are available for download in DXF, TIFF and PDF format at the Customised Solution Portal of Volkswagen AG. All files (except PDFs) are packed as Zip archives. The files can be unpacked using Winzip (PC) or Ziplt (MAC).

Information

Current build dimension drawings are available for download from the Customised Solution Portal of Volkswagen AG under the “Technical drawings” menu option.

5.2 Diagrams (foil templates)

Vehicle views of the Caddy and Caddy Maxi in 1:25 scale are available for download in TIF, DXF and EPS format to help you create diagrams. All files are packed as Zip archives. The files can be unpacked using Winzip (PC) or ZiptIt (MAC).

Information

Current diagrams are available for downloading from the Customised Solution Portal of Volkswagen AG under the “Foil templates” menu item.

5.3 Current flow diagrams

For detailed information about this topic, refer to the Workshop Manuals and current flow diagrams of Volkswagen AG.

Information

Volkswagen AG Workshop Manuals and current flow diagrams can be downloaded from the Internet at **erWin*** (Electronic Repair and Workshop Information from Volkswagen AG):
<http://erwin.volkswagen.de/erwin/showHome.do>

*Information system from Volkswagen AG, subject to payment

5.4 CAD models

On request, Converters can receive 3D data models in the CATIA V.5 and STEP formats for design purposes.

Information

The available 3D data can be found on the Customised Solution Portal of Volkswagen AG under menu option "Technical information/CAD data"*.

*Registration required.

6 Calculations

6.1 Determining the centre of gravity

The overall centre of gravity height (vehicle with add-ons or complete body without load) should be kept as low as possible.

The centre of gravity in the vehicle longitudinal direction is given in relation to a vehicle axle. The centre of gravity height is related to the wheel hub or related to the road. Volkswagen recommends having the centre of gravity determined by a recognised test institution with experience in this field (e.g., DEKRA, TÜV or others).

For the Converter to determine the centre of gravity, we recommend following the procedure described in [chapters 6.1.1 “Determining the centre of gravity in x-direction”](#) and [6.1.2 “Determining the centre of gravity in z-direction”](#) and using personnel with the corresponding qualifications to obtain usable results.

6.1.1 Determining the centre of gravity in x-direction

Procedure:

The vehicle must be weighed without load and with the add-ons or complete body.

Inflate the tyres up to the tyre pressure that is specified for the respective gross axle weight rating.

Completely fill all fluid containers (fuel tank, washer fluid reservoir, if applicable, hydraulic tank, water tank etc.).

Drive the vehicle onto the scales, switch off the engine, shift the gearbox to neutral and release the brakes.

The vehicle must be standing horizontal and level for weighing.

First weigh the individual axle loads (front and rear axle load) and then the gross weight of the vehicle.

The measured values can be used to calculate the position of the centre of gravity in the vehicle longitudinal direction with the equations (3) and (4). Equation (2) should be used to check the results of (3) and (4).

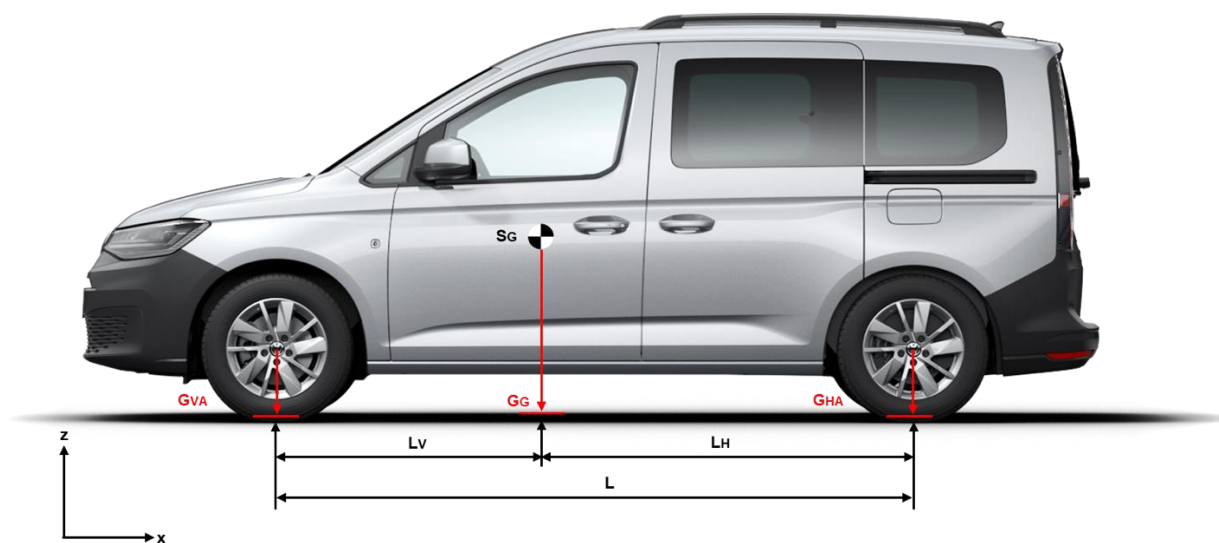

Fig. 1: Determining the position of the vehicle centre of gravity in x-direction

Determining the total weight of the unladen vehicle with add-ons and body.

$$G_G = G_{HA} + G_{VA} \quad (1)$$

Calculating the position of the overall centre of gravity S_G in x-direction

$$L = L_V + L_H \quad (2)$$

$$L_V = \frac{G_{HA}}{G_G} L \quad (3)$$

$$L_H = \frac{G_{VA}}{G_G} L \quad (4)$$

Abbreviations and parameters used:

G_G	-	Total weight of unladen vehicle
G_{VA}	-	Front axle load of unladen vehicle (specification or weighing of respective chassis)
G_{HA}	-	Rear axle load of unladen vehicle (specification or weighing of respective chassis)
S_G	-	Overall vehicle centre of gravity
L	-	Wheelbase
L_V	-	Distance from the overall centre of gravity of the empty vehicle to the front axle
L_H	-	Distance from the overall centre of gravity of the empty vehicle to the rear axle

Practical note

The practical determination of the centre of gravity height may only be performed by appropriately qualified personnel with the help of suitable and calibrated scales.

To reduce measuring errors, each measured value should be calculated at least three times and an average value calculated from the three results. This value is then used for calculating in accordance with the equations (3) and (4).

6.1.2 Determining the centre of gravity in z-direction

So that the Converter can determine the vehicle total centre of gravity height h_s (see Fig. 1), Volkswagen AG recommends the following procedure after completion of the whole vehicle:

After conversion, the vehicle should be weighed on board scales or on suitable wheel load scales in two subsequent driving positions.

Here, the measured axle loads shall be determined with the vehicle in a level state G_{FA} and G_{RA} (see [chapter 6.1.1 “Determining the centre of gravity in x-direction”](#)) and the axle loads on an axle (Q_{RA} or Q_{FA}) increased by the quantity h' .

The raising height h' should be as high as possible in accordance with the front and rear ramp angles of the vehicle (also known as approach/departure angle). The target value is >600 mm.

To reduce measuring errors, at least six individual measurements should be made in the axle load calculation for each axle: three per axle with vehicle level and three each with raised axle.

The average value for each axle should be calculated from the three measurements for a state. The average value should be calculated from these three values and used in the calculations with the equations (5) to (9).

To improve the accuracy of the final result, the axle load modification should be determined with raised rear axle and raised front axle.

Practical note

Observe the following to avoid incorrect measurements:

The vehicle must be standing perfectly horizontal for weighing in level vehicle state. Height differences between the axles caused by scales should be compensated accordingly.

When raising to the required lifting height, the axle being weighed should be locked to prevent suspension compression or extension.

When raising to the required lifting height, no part of the vehicle may touch the ground.

All vehicle wheels must be able to rotate freely: select neutral, release all brakes including handbrake and place chocks at sufficient distance from the wheels, if necessary.

Move vehicle with own power (to weigh the respective other vehicle axle) to relieve any tension in the vehicle.

Ensure that no objects inside the vehicle can move during the measurements.

If the vehicle suspension cannot be locked due to the body design or available space, further axle load measurements must be carried out at different levels (for example, 600 mm, 700 mm and 800 mm). This also allows errors to be limited by averaging. The centre of gravity height results from the arithmetic average of the individual centre of gravity heights for each raising height.

Example of procedure:

1. The vehicle must be weighed without load and with the add-ons or complete body.
2. Inflate the tyres up to the tyre pressure that is specified for the respective gross axle weight rating.
3. Completely fill all fluid containers (fuel tank, washer fluid reservoir, if applicable, hydraulic tank, water tank etc.).
4. On the scales, switch off the engine, set gearbox to neutral and release the brakes.
5. Position the vehicle with the rear axle (RA) horizontal and level on the scales and measure the axle load.
6. Raise the front axle by the value h' , at least 600 mm. A greater height h' taking the other vehicle-related conditions into consideration is more favourable for the final result. The value h' must be measured for all individual measurements with raised axle and should be as identical as possible. Alternatively to the raised height h' , the angle α between the wheel hubs can be defined.
7. Determine the axle load displacement QHA that occurs at the rear axle on the scales.
8. Lower and turn the vehicle around and perform the corresponding measurements on the front axle (first GFA with level real axle and then QFA with the rear axle raised by h').
9. Perform steps 4–7 a total of three times (with locked suspension).
10. The measured values can be used to calculate the height of the centre of gravity with the equations (5) to (9).
11. In the calculations using the equations (3) to (9), all length measurements are in millimetres (mm) and all weight figures in decanewton (1 daN = 10 N). *
12. Raise the raised axle further (by e.g. 100 mm) and measure the height of the centre of gravity again to confirm the measuring result.

Practical note

The practical determination of the centre of gravity height may only be performed by appropriately qualified personnel with the help of suitable and calibrated measuring systems and measuring tools.

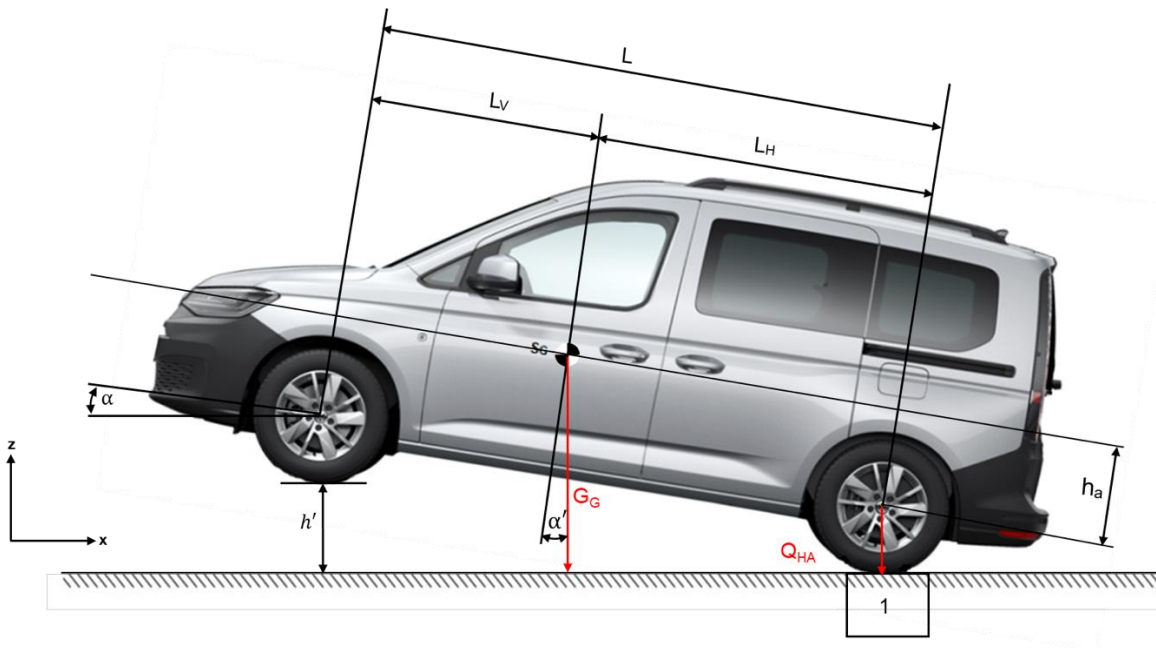

Fig. 1: Determining the position of the vehicle centre of gravity in z-direction

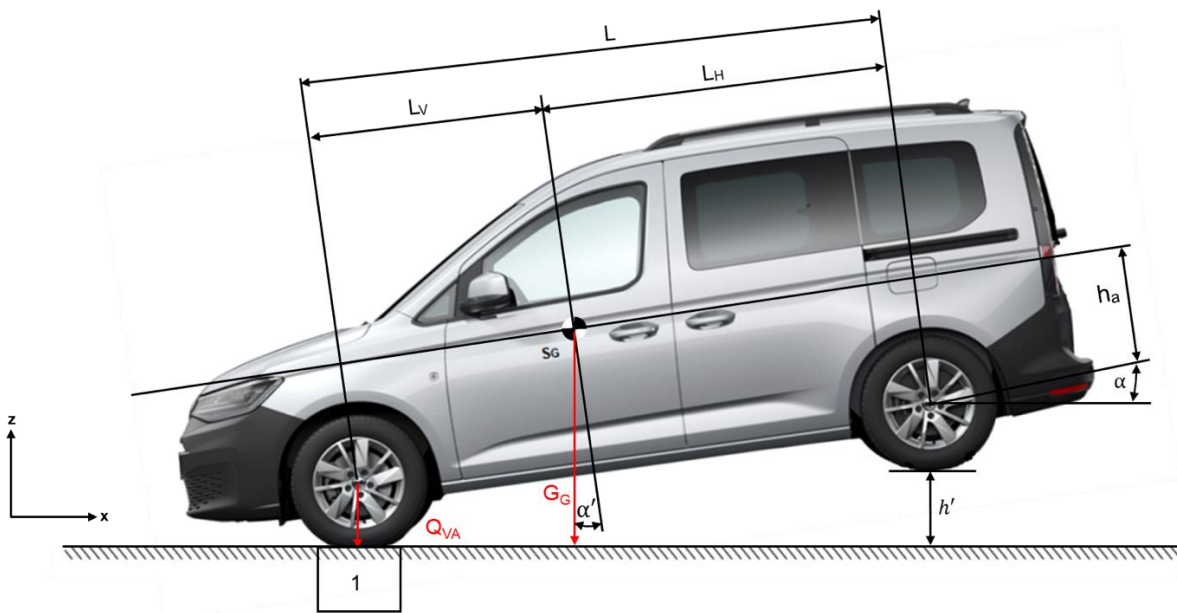

Fig. 2: Determining the location of the vehicle centre of gravity in z-direction

Determining the overall centre of gravity S_G in z-direction:

$$h_S = h_a + r_{stat} \quad (5)$$

Determining the overall centre of gravity S_G in z-direction for the raised front axle:

$$h_S = \left(\frac{Q_{HA} - G_{HA}}{G_G} \times L \times \frac{1}{\tan \alpha} \right) + r_{stat} \quad (6)$$

$$\sin \alpha = \frac{h'}{L} \quad (6a)$$

$$\alpha = \arcsin \left(\frac{h'}{L} \right) \quad (6b)$$

$$\cos \alpha = \frac{\sqrt{L^2 - h'^2}}{L} \quad (6c)$$

$$\tan \alpha = \frac{h'}{\sqrt{L^2 - h'^2}} \quad (6d)$$

$$\frac{1}{\tan \alpha} = \frac{\sqrt{L^2 - h'^2}}{h'} = \frac{1}{h'} \sqrt{L^2 - h'^2} \quad (6e)$$

$$h_S = \left(\frac{1}{h'} \times \frac{Q_{HA} - G_{HA}}{G_G} \times L \times \sqrt{L^2 - h'^2} \right) + r_{stat} \quad (7)$$

Determining the overall centre of gravity S_G in z-direction for the raised rear axle:

$$h_S = \left(\frac{Q_{VA} - G_{VA}}{G_G} \times L \times \frac{1}{\tan \alpha} \right) + r_{stat} \quad (8)$$

$$\sin \alpha = \frac{h'}{L} \quad (8a)$$

$$\alpha = \arcsin \left(\frac{h'}{L} \right) \quad (8b)$$

$$\cos \alpha = \frac{\sqrt{L^2 - h'^2}}{L} \quad (8c)$$

$$\tan \alpha = \frac{h'}{\sqrt{L^2 - h'^2}} \quad (8d)$$

$$\frac{1}{\tan \alpha} = \frac{\sqrt{L^2 - h'^2}}{h'} = \frac{1}{h'} \sqrt{L^2 - h'^2} \quad (8e)$$

$$h_S = \left(\frac{1}{h'} \times \frac{Q_{VA} - G_{VA}}{G_G} \times L \times \sqrt{L^2 - h'^2} \right) + r_{stat} \quad (9)$$

Abbreviations and parameters used:

r_{stat}	-	Static tyre radius
Q_{VA}	-	Front axle load when vehicle raised at rear
Q_{HA}	-	Rear axle load when vehicle raised at front
G_G	-	Total weight of unladen vehicle
G_{VA}	-	Front axle load of unladen vehicle (specification or weighing of respective chassis)
G_{HA}	-	Rear axle load of unladen vehicle (specification or weighing of respective chassis)
L	-	Wheelbase
L_V	-	Distance from the overall centre of gravity of the empty vehicle to the front axle
L_H	-	Distance from the overall centre of gravity of the empty vehicle to the rear axle
h_S	-	Centre of gravity height over road
h_a	-	Centre of gravity height over centre of wheel
h'	-	Height by which the vehicle has been raised
1	-	Weighing equipment

7 Weights (masses)

When ordering your vehicle, please note that the kerb weight increases when additional equipment is selected and the available payload capacity is therefore reduced.

Due to the continual changes to the base vehicle, all vehicle weights are available via the country-specific sales documents on the internet or via the Customised Solution Portal (www.customized-solution.com).

We recommend determining the definitive kerb weight of the entire vehicle by weighing before the conversion.

For further questions, please contact your Volkswagen Commercial Vehicles dealer, your importer or our Customer Care (see [chapter 1.2.1.1 "Contact in Germany"](#), [1.2.1.2 "International contact"](#)).

Practical note

For vehicle earth/dimensions, the following weight tolerances apply:

- 3% for vehicle classes M/N (excluding vehicles for special purposes)
- 5% for vehicles with special intended use

8 Notes on homologation of modifications and conversions

8.1 Availability with complete Certificate of Conformity ex works – light duty WLTP

Applies to		Caddy, Caddy Cargo
Drive type:		Front and 4x4 (all-wheel drive)
Design		Caddy, Caddy Cargo
Type of homologation:		Light duty
WLTP calculator:		Calculation of conversions with the WLTP calculator possible
Calculable dimensions:		End face and vehicle mass in ready-to-drive state

Values for max. end face [in cm²] and max. vehicle mass in ready-to-drive state [in kg] [see chapter 8.2.1](#). All of the above information relates to Caddy, Caddy Cargo.

VH (vehicle high) document in compliance with technical maximum values and special conversion applications possible (no recalculation).

Information

Valid for the approved engine-gearbox variants (see offer for countries).

The max. values depend on the drive/weight combination.

Information

For all vehicles/engine-gearbox variants for which no values can currently be generated using the WLTP calculator, please contact your responsible technical service department and check whether individual approval or multi-stage type approval is possible.

8.2 Technical specifications

Affected: all engine-gearbox variants (EGV)

Note: For all engine gearbox versions, calculation for conversions with weight changes is possible in the Customised Solution Portal (WLTP calculator).

For the engine/gearbox variants listed below, conversions with end face change and weight change are possible; a document for stage 2 can be called up in the WLTP calculation tool for this purpose. The specifications for max. weights and end faces must be observed.

8.2.1 Permissible aerodynamic changes and min./max. weights apply to the following variants:

Caddy Cargo / Caddy

EGV	M1 VH Converter weight in kg* (1)				N1 VH Converter weight in kg*			
	Short wheelbase		Long wheelbase		Short wheelbase		Long wheelbase	
	5 seats	7 seats	5 seats	7 seats	2 seats (Caddy Cargo)	5 seats (Caddy/com mercial)	2 seats (Caddy Cargo)	5 seats (Caddy/com mercial)
90 kW TDI MQ 4x4	1,546– 2,038	1,519– 2,011	1,537– 2,029	1,510– 2,003	1,408– 1,989	1,369–1,950	1,389–1,970	1,350–1,931
90 kW TDI DQ	1,403– 2,220	1,376– 2,206	1,394– 2,220	1,367– 2,197	1,268– 2,220	1,200–2,180	1,229–2,209	1,190–2,170
75 kW TDI MQ	1,368– 2,201	1,345– 2,193	1,354– 2,201	1,327– 2,175	1,232– 2,201	1,162–2,163	1,201–2,201	1,152–2,143
55 kW TDI MQ	1,421– 1,903	--	--	--	1,295– 1,863	1,244–1,813	1,295–1,863	--
85 kW TSI MQ	1,307– 2,114	1,281– 2,099	1,295– 2,113	1,272– 2,090	1,173– 2,114	1,115–2,081	1,134–2,100	1,115–2,081
85 kW TSI DQ	1,332– 2,149	1,306– 2,140	1,320– 2,149	1,297– 2,131	1,202– 2,149	1,125–2,110	1,164–2,149	1,125–2,110
PHEV	1,657– 2,076	--	1,643– 2,063	1,643– 2,052	1,545– 2,041	1,536–2,031	1,507–2,002	1,507–2,002

* Converter max. kerb weight = perm. max. kerb weight ready to drive incl. conversion/body by the Converter (without driver)

(1) does not apply to the Caddy California variant

The specified kerb weight range for a variant/version is calculated from the specific gross vehicle weight rating. A change in seating does result in any changes to the range.

Information







For all vehicles/engine-gearbox variants for which no values can currently be generated using the WLTP calculator, please contact your responsible technical service department and check whether individual approval or multi-stage type approval is possible.

8.2.2 Permissible aerodynamic changes and max. dimensions

Affected: All engine-gearbox variants

Notes: Technical description of aerodynamic bodies

Conversions with end face change **and** weight change are possible. For this, a document for the 2nd stage can be retrieved in the WLTP calculator (specification for maximum weight and area must be observed).

Scope	Max. installation space WxLxH	Example	Notes
Roof ventilator	WxLxH 310x310x135 mm		<p>The maximum dimensions of the variants must not be exceeded.</p> <p>The new second stage exhaust document is not valid for other bodies.</p> <p>More information can be found in these Converter guidelines, which must be observed.</p>
Rotating lights	D=160 mm H=205 mm		
Refrigerated vehicles	WxLxH 775x580x180 mm		
Special signal system	WxLxH 1,100x415x150 mm		
Special signal system	WxLxH 1,100x415x150 mm		
Roof-mounted turn signals	D=180 mm		
Ventilation grate	WxLxH 50x300x100 mm		

Information

For all vehicles/engine-gearbox variants for which no values can currently be generated using the WLTP calculator, please contact your responsible technical service department and check whether individual approval or multi-stage type approval is possible.

9 Listings

9.1 List of changes

Changes to the Converter guidelines compared to the data status of August 2024.

Chapter no.	Chapter heading	Scope of change
1	General information	
1.1	Introduction	
1.1.1	Concept of this Owner's Manual	
1.1.2	Means of representation	
1.1.3	Vehicle safety	
1.1.4	Operational safety	
1.1.5	Note on copyright	
1.2	General information	
1.2.1	Product and vehicle information for Converters	
1.2.1.1	Contact in Germany	
1.2.1.2	International contact	
1.2.1.3	Electronic Repair and Workshop Information from Volkswagen AG (erWin)	
1.2.1.4	Genuine Parts Online Order Portal	
1.2.1.5	Online Owner's Manual	
1.2.1.6	Homologation	
1.2.1.7	European Type Approval and EC Certificate of Conformity (CoC)	
1.2.1.8	Worldwide Harmonised Light Vehicles Test Procedure (WLTP)	
1.2.1.9	Manufacturer's declaration	
1.2.2	Converter guidelines, consulting	
1.2.2.1	Letter of non-objection	
1.2.2.2	Application for the letter of non-objection	
1.2.2.3	Legal entitlements	
1.2.3	Warranty and product liability of the Converter	
1.2.4	Ensuring traceability	
1.2.5	Badges	
1.2.5.1	Positions on rear of the vehicle	
1.2.5.2	Appearance of whole vehicle	
1.2.5.3	Non-Volkswagen badge	
1.2.6	Recommendation for vehicle storage	
1.2.7	Compliance with environmental rules and regulations	
1.2.8	Recommendations for inspection, maintenance and repair	
1.2.9	Accident prevention	
1.2.10	Quality system	

Chapter no.	Chapter heading	Scope of change
1.3	Planning bodies	
1.3.1	Selecting the basic vehicle	
1.3.2	Vehicle modifications	
1.3.3	Vehicle acceptance	
1.4	Special equipment	
2	Technical data for planning	
2.1	Basic vehicle	
2.1.1	Vehicle dimensions	
2.1.1.1	Basic data of Caddy Caddy Cargo	
2.1.1.2	Basic data for Caddy	
2.1.2	Ramp angle and breakover angle	
2.1.3	Vehicle centre of gravity	
2.1.4	Bodies with a high centre of gravity	
2.1.5	Determining centre of gravity	
2.1.6	Steerability – minimum front axle load	
2.2	Running gear	
2.2.1	Permitted weights and kerb weights	
2.2.1.1	One-sided weight distribution	
2.2.2	Turning circle	
2.2.3	Approved tyre sizes	
2.2.4	Modifications to axles	
2.2.5	Modifications to the steering system	
2.2.6	Brake system and brake control system ESC*	
2.2.6.1	General information	
2.2.6.2	Vehicle stability and ESC*	
2.2.6.3	Influence of vehicle conversions on the function of the brake control system ESC*	
2.2.6.4	Routing additional lines along the brake hoses/brake lines	
2.2.7	Modification of springs, suspension mounting, dampers	
2.2.7.1	Rear axle running gear for heavy installations (retrofit kit, PR number UC5)	
2.2.8	Wheel alignment settings	
2.3	Building shell	
2.3.1	Roof loads/vehicle roof	
2.3.1.1	Dynamic roof loads	
2.3.2	Modifications to the body-in-white	
2.3.2.1	Bolted connections	
2.3.2.2	Welding work	
2.3.2.3	Welded connections	
2.3.2.4	Selection of welding process	

Chapter no.	Chapter heading	Scope of change
2.3.2.5	Resistance spot welding	
2.3.2.6	Shielding gas plug welding	
2.3.2.7	Tacking	
2.3.2.8	Welding is not allowed	
2.3.2.9	Corrosion protection after welding	
2.3.2.10	Corrosion protection measures	
2.3.2.11	Planning measures	
2.3.2.12	Component design measures	
2.3.2.13	Coating measures	
2.3.2.14	Work on the vehicle	
2.4	Interior	
2.4.1	Modifications in the area of airbags	
2.4.2	Modifications in the area of seats	
2.4.2.1	Belt anchors	
2.4.3	Forced ventilation	
2.4.4	Acoustic insulation	
2.5	Electrics/electronics	
2.5.1	Lighting	
2.5.1.1	Vehicle lighting devices	
2.5.1.2	Mounting special lights	
2.5.1.3	Additional load compartment light	
2.5.2	Electrical system	
2.5.2.1	Electrical wiring/fuses	
2.5.2.2	Additional circuits	
2.5.2.3	Retrofitting electrical devices	
2.5.2.4	Electromagnetic compatibility	
2.5.2.5	Mobile communication systems	
2.5.2.6	Infotainment	
2.5.2.7	Current and signal take-off of vehicle electrical system potentials	
2.5.3	Electrical interface for special vehicles	
2.5.3.1	General notes on the interfaces	
2.5.3.2	230 V DC/AC converter (PR no. 9Z3, 9Z6)	
2.5.3.3	Customer-specific functional control unit (CFCU)	
2.5.4	Vehicle battery	Chapter updated
2.5.4.1	Installation of additional battery	
2.5.4.2	Intelligent external charging control	
2.5.4.3	Parameterised* reactions on reaching certain second battery charge levels with second battery monitoring	
2.5.5	Retrofitting of alternators	
2.5.6	Driver assist systems	

Chapter no.	Chapter heading	Scope of change
2.5.6.1	General overview	
2.5.6.2	Electromechanical steering	
2.5.6.3	Electronic Stability Control (ESC)	
2.5.6.4	Tyre pressure monitoring system	
2.5.6.5	Front camera for driver assist systems	
2.5.6.6	Rain/light sensor	
2.5.6.7	Parking aids	
2.5.6.8	Lane departure warning "Lane Assist"	
2.5.6.9	Front Assist / ACC	
2.5.7	Earth points	
2.6	Engine peripherals/drive train	
2.6.1	Engine / drive train components	
2.6.2	Drive shafts	
2.6.3	Fuel system	
2.6.3.1	CNG fuel system	
2.6.4	Exhaust system	
2.6.4.1	Hybrid drive exhaust system (PHEV)	Chapter updated
2.6.4.2	4x4 drive exhaust system	Chapter added
2.6.5	SCR system (EU6)	
2.6.5.1	Installation position of the AdBlue tank in the vehicle	
2.6.5.2	Filling the AdBlue tank	
2.7	Engine power take-off systems	
2.7.1	Compatibility with base vehicle	
2.7.2	Retrofitting an air conditioning system	
2.7.3	Retrofit load compartment cooling	
2.7.4.	Specifications for the genuine refrigerant compressor	
2.7.4.1	Maximum cooling output	
2.7.4.2	Weight of the refrigerant compressor	
2.7.4.3	Pulley diameter of the refrigerant compressor	
2.7.4.4	Specification of the poly V-belt	
2.7.4.5	Connection dimensions of original refrigerant compressor	
2.8	Add-ons/units	
2.8.1	Roof carriers	
2.8.2	Rear luggage carrier/rear ladders	
2.8.3	Towing brackets / clearance acc. to DIN 74058	
2.8.3.1	Maximum trailer weights	
2.8.3.2	Retrofitting a towing bracket	
2.8.3.3	Clearance according to UN-R 55	
2.9	Raising the vehicle	
3	Modifications to closed bodies	

Chapter no.	Chapter heading	Scope of change
3.1	Body-in-white/bodywork	
3.1.1	Side wall cut-outs	
3.1.2	Subsequent installation of windows	
3.1.3	Roof cut-outs	
3.1.4	Modifications to the roof of the Caddy Cargo/Caddy	
3.1.5	Modifying the partition/forced ventilation vent	
3.1.6	Partition connection points	
3.2	Interior	
3.2.1	Safety features	
3.2.2	eCall Emergency System	
3.2.3	Seat retrofitting/seating with standard seats	
3.3	Add-ons	
3.3.1	Accessories	
4	Implementation of special bodies	
4.1	Vehicles for persons with a mobility impairment	
4.1.1	Basic vehicle equipment	
4.1.2	Selection of steering rack for conversions for people with disabilities	
4.1.3	Notes on conversion solutions for the wheelchair transporter	
4.1.4	Notes on installing manual operating devices for the foot brake	
4.1.5	Deactivating the airbag/belt tensioner system	
4.2	Refrigerated vehicles	
4.3	Shelf installation/workshop vehicles	
4.3.1	Shelf and workshop installations	
4.4	Emergency service vehicles	
4.5	Preparation for taxis and private hire cars	
4.5.1	Preparation for taxis and private hire cars ex works	
4.5.2	Pin assignment on CFCU* (input and output assignment/pins on CFCU*)	
4.5.3	Functional description	
4.5.4	Programming according to customer requirements	
4.6	Recreational vehicles	
4.7	Vehicles for local and public authorities	
4.8	Vehicles for couriers and logistics	
4.9	Plug-in hybrid electric vehicle (PHEV)	
4.9.1	High-voltage system	
4.9.1.1	Power and control electronics for electric drive	
4.9.1.2	Modifications to the underbody area of the high-voltage battery and the drive	
4.9.2	12-V vehicle electrical system	

Chapter no.	Chapter heading	Scope of change
5	Technical data	
5.1	Build dimension drawings	
5.2	Diagrams (foil templates)	
5.3	Current flow diagrams	
5.4	CAD models	
6	Calculations	
6.1	Determining centre of gravity	
6.1.1	Determining the centre of gravity in x-direction	
6.1.2	Determining the centre of gravity in z-direction	
7	Weights (masses)	
8	Notes on homologation of equipping and conversions	
8.1	Availability with complete Certificate of Conformity ex works – light duty WLTP	Chapter updated
8.2	Technical specifications	
8.2.1	Permissible aerodynamic changes and min./max. weights apply to the following variants	Chapter updated
8.2.2	Permissible aerodynamic changes and max. dimensions	Chapter updated
9	Listings	
9.1	List of changes	
Last page	Title, Brieffach, issue date	

Converter guidelines

The Caddy

Converter guidelines

Subject to change without notice

November 2024 edition

Internet:

<https://www.volkswagen-nutzfahrzeuge.de>

<https://www.customized-solution.com>

Consulting for Converters in Germany is available from the listed address.

Volkswagen Commercial Vehicles

Brieffach 2949

Postfach 21 05 80

D-30405 Hannover