

Converter guidelines
October 2024 edition



Commercial
Vehicles

Converter guidelines

The new Amarok (from model year 2023)



Table of contents

1	General information	6
1.1	Introduction	6
1.1.1	Concept of this Owner's Manual	6
1.1.2	Means of representation	7
1.1.3	Vehicle safety	8
1.1.4	Operational safety	9
1.1.5	Note on copyright	9
1.2	General information	10
1.2.1	Product and vehicle information for converters	10
1.2.1.1	Contact in Germany	10
1.2.1.2	International contact	10
1.2.1.3	Electronic repair and workshop information from Volkswagen AG (erWin*)	11
1.2.1.4	Genuine Parts Online Ordering Portal*	11
1.2.1.5	Online Owner's Manual	11
1.2.1.6	European Type Approval (ETA) and EC Certificate of Conformity (CoC)	11
1.2.1.7	Worldwide Harmonized Light-Duty Vehicles Test Procedure (WLTP)	12
1.2.2	Converter guidelines, consulting	13
1.2.2.1	Letter of non-objection	13
1.2.2.2	Application for the letter of non-objection	15
1.2.2.3	Legal entitlements	16
1.2.3	Warranty and product liability of the converter	16
1.2.4	Ensuring traceability	17
1.2.5	Badges	17
1.2.5.1	Positions on rear of the vehicle	17
1.2.5.2	Appearance of whole vehicle	17
1.2.5.3	Non-Volkswagen trademarks	17
1.2.6	Recommendations for vehicle storage	17
1.2.7	Compliance with environmental rules and regulations	20
1.2.8	Recommendations for inspection, maintenance and repair	21
1.2.9	Accident prevention	21
1.2.10	Quality system	22
1.3	Planning bodies	23
1.3.1	Selecting the basic vehicle	23
1.3.2	Vehicle modifications	24
1.3.3	Vehicle acceptance	25
1.4	Special equipment	26
1.5	Commercial aspects	27
1.5.1	Restraint system	27
1.5.2	Drilling and welding	27
1.5.3	Minimum requirements for the brake system	27
1.5.4	Road safety	27
1.6	Electromagnetic compatibility (EMC)	28
1.6.1	Pickup	29
1.7	Raising the vehicle with a jack	30
1.7.1	Vehicle jacking points and axle stand positions	31
1.8	Raising the vehicle with a lifting platform	32
1.9	Noise, vibration and harshness (NVH)	34
1.10	Vehicle transport aids and vehicle storage	35

1.11 Assemblies and ergonomics	37
1.11.1 General guidelines for assemblies	37
1.11.2 Driver's operating area	37
1.11.3 Driver's field of vision	37
1.11.4 Effects of conversions on parking aids	37
1.11.5 Aids for entering and exiting vehicles	38
1.11.6 Worldwide Harmonised Light Vehicles Test Procedure (WLTP) calculation inputs	39
1.11.7 Mass of the finished vehicle	39
1.11.8 Frontal surface	39
1.11.9 Rolling resistance of tyres	39
1.11.10 Key to vehicle dimensions	40
1.11.11 Recommended main load range dimensions	40
1.11.12 WLTP front area calculation	41
1.11.13 Number plate	44
1.12 Assemblies and ergonomics – specifications	45
1.12.1 Recommended body dimensions	45
1.12.2 Technical data for planning/base vehicle	47
1.12.3 Unladen mass and payload	48
1.12.4 Gross vehicle mass and axle load	48
1.12.5 Front, rear and side skid plate	48
1.12.6 Rear skid plate – chassis with cab	48
1.13 Components – specifications	49
1.14 Load distribution – specifications	50
1.14.1 Load distribution calculations – weight distribution of driver and front passenger	50
1.14.2 Centre of gravity	51
1.15 Towing brackets	53
1.15.1 Requirements for the towing brackets	53
1.15.2 Use of the towing bracket	53
1.15.3 Towing capacities and specifications	53
2 Chassis	54
2.1 Running gear suspension	54
2.2 Brake system	55
2.2.1 General information	55
2.2.2 Brake hoses	55
2.2.3 Overrun brake connection	56
3 Drive train	57
3.1 Engine	57
3.1.1 Air flow areas of the engine cooling system	57
3.1.2 Engine selection for conversions	57
3.2 Fuel system	58
3.2.1 Securing the fuel filler neck during transport	58
3.2.2 Securing the fuel filling system	59
3.2.3 Breather hose for fuel filling system (diesel)	63
3.2.4 Breather hose for axle venting	64
3.2.5 Fuel tanks with a big fuel range	65
3.3 System for “Selective Catalytic Reduction (SCR)”	66
3.3.1 Selective catalytic reduction system – diesel exhaust fluid (reducing agent)	66
4 Electrics	75
4.1 Installation and routing guidelines for electrical wiring	75
4.1.1 Wiring splicing method	75

4.1.2 Cable guide through cab panel	75
4.2 Battery and cables	77
4.2.1 Battery information	77
4.2.2 Connection of additional loads/accessories – for vehicles with factory-installed additional switches, wiring and fuse boxes	90
4.2.3 Alternator	93
4.2.4 Ignition signal	95
4.3 Parking aid	96
4.3.1 Sensor positions	99
4.4 Engine management system	101
4.4.1 Tachograph	101
4.4.2 Vehicle speed signal	101
4.5 Information and infotainment system	103
4.5.1 Reversing camera	103
4.6 Exterior lighting	108
4.6.1 Rear combination lights	109
4.6.2 Rear fog light	110
4.6.3 Rear number plate lights	112
4.6.4 Additional exterior lights	113
4.6.5 Headlights – connecting an additional main beam signal	113
4.6.6 Brake lights	116
4.6.7 Side marker lights (parking lights)	116
4.6.8 Reversing lights, reversing camera, reversing alarm (manual gearbox)	117
4.6.9 Towing mode – lighting connections	117
4.6.10 Lights – hazard warning lights / turn signals	121
4.6.11 Electrically operated exterior mirrors	122
4.6.12 High-mounted centre brake light	122
4.6.13 Main beam assist	123
4.6.14 Glare-free main beam	123
4.6.15 Parking brake signal	123
4.7 Cruise control system	124
4.7.1 Adaptive cruise control	124
4.8 Driver assist systems	126
4.9 Overhead view camera – Area View	130
4.10 Side view camera	132
4.11 Lane departure warning (Lane Assist)	134
4.12 Handles, locks, catches and access systems	135
4.12.1 Central locking system	135
4.13 Fuses and relays	136
4.13.1 Fuses	136
5 Body and paint	137
5.1 Body	137
5.1.1 Body structures – general information	137
5.1.2 Add-on parts on the vehicle frame , wheel housing cover	139
5.1.3 Chassis frame	141
5.1.4 Properties of the front section for cooling, collision, aerodynamics and lighting	145
5.1.5 Tipper bodies	145
5.1.6 Tank and bulk container superstructure	146
5.1.7 Aerial cable routing	146
5.1.8 Roof loads and roof carriers	147
5.1.9 Add-on parts on the cargo box	148

5.1.10 Front wing trim	155
5.2 Airbag systems.....	156
5.2.1 Airbags	156
5.2.2 Additional impact sensors (front).....	160
5.3 Seat belt systems	162
5.3.1 Seat belts – permitted drilling zones	162
5.4 Corrosion protection	164
5.4.1 General information	164
5.4.2 Touching up damaged paintwork	164
5.4.3 Underseal and materials	164
5.4.4 Painting rims.....	164
5.4.5 Galvanic (bi-metallic) corrosion / contact corrosion	164
5.5 Frame and body mounting	165
5.5.1 Mounting points and pipes	165
5.5.2 Removing rear seats	167
5.5.3 Self-supporting body structure.....	168
5.5.4 Frame drilling and tube reinforcement.....	169
5.5.5 Additional equipment – subframe attachment.....	170
5.5.6 Area for fitting additional body attachments to the rear of the bumper	170
5.5.7 Water tank on camping vehicles	171
5.5.8 Conversions with an extended wheelbase.....	171
6 Technical data.....	175
6.1 Build dimension drawings	175
6.2 Diagrams (foil templates).....	175
6.3 Current flow diagrams	175
6.4 CAD models	176
7 Weights (masses).....	177
8 Homologation	178
8.1 Notes on homologation of modifications and conversions	178
9 Listings.....	180
9.1 List of changes	180

1 General information

1.1 Introduction

These converter guidelines provide converters with important technical information which must be complied with when planning and manufacturing a body for road safety and operational reliability. The add-on, body, installation or conversion work required for this is referred to below as “body activities”.

Due to the vast number of converters and types of bodies, it is not possible for Volkswagen AG to predict all possible modifications which can occur due to the body activities, e.g. with regard to vehicle handling, stability, weight distribution, centre of gravity of the vehicle and its handling characteristics. Therefore, Volkswagen AG does not accept any liability for accidents or injuries arising from modifications of this kind made to its vehicles, especially if the changes have a negative effect on the vehicle as a whole. As a result, Volkswagen AG only accepts liability for its own design, production and instruction services. The converter itself is obliged to ensure that its body activities are not faulty in themselves, and also that they cannot result in faults or dangers on the vehicle as a whole. The converter must also ensure the conformity of the body activities with the respective and applicable laws (in particular approval and registration processes). The converter itself is liable in the event that this obligation is violated.

These converter guidelines are intended for professional converters. As a result, these converter guidelines assume corresponding background knowledge. Note that some work (e.g. welding on load-bearing parts) is only allowed to be performed by appropriately qualified personnel. This requirement exists in order to avoid risks of injury and to achieve the quality needed in the body activities.

1.1.1 Concept of this Owner's Manual

The following converter guidelines are divided into 8 chapters so that you can find information rapidly:

1. General information
2. Chassis
3. Drive train
4. Electrical
5. Body and paint
6. Technical data
7. Weights (masses)
8. Homologation
9. Listings

Information

For more information, see [1.2.1.1 “Contact”](#) and [1.2.2 “Converter guidelines, consulting”](#).

1.1.2 Means of representation

The following means of representation are used in these converter guidelines:

Warning note

A danger note draws your attention to possible accident or injury risks to which you or other persons might be exposed.

Environmental note

An environmental note provides you with information about environmental protection.

Practical note

This note draws your attention to the risk of possible damage to the vehicle, as well as to regulations and provisions to be observed.

Information

This note indicates additional information.

1.1.3 Vehicle safety

Warning note

Before assembling external bodies or power units, it is essential that you read the chapters in these converter guidelines that are related to installation, as well as corresponding chapters in the instructions and information for the suppliers' power units and in the detailed Owner's Manual for the basic vehicle. Otherwise you will not be able to recognise dangers, and might expose yourself or others to danger.

We recommend that you use parts, power units, conversion parts or accessories that have been tested by Volkswagen AG for the corresponding vehicle type.

Have the vehicle's safety checked immediately if non-recommended parts, power units, conversion parts or accessories are used.

Practical note

It is essential that you comply with European vehicle approval or UNECE R regulations, as well as national registration regulations and also technical vehicle regulations. This is because body activities on the vehicle can alter the vehicle type under registration regulations and the operating permit may be invalidated.

This applies in particular to:

- Modifications which change the vehicle type approved in the operating permit
- modifications which might be expected to endanger road users or
- modifications which impair the exhaust or noise emissions characteristics

1.1.4 Operational safety

Warning note

Incorrect interventions in electronic components and their software may result in these no longer functioning. Due to the networking of electronics, systems that were not modified can be affected.

Malfunctions to the electronics can significantly impair the operational safety of the vehicle.

Work on or modifications to electronic components must be performed by a qualified specialist workshop that has the necessary specialist knowledge and tools to perform the necessary work.

Volkswagen AG recommends a Volkswagen Commercial Vehicles partner for this or contact your importer.

Service by a qualified specialist workshop is essential, in particular for safety-relevant work and work on safety-relevant systems.

Some safety systems only operate when the engine is running. Therefore, do not switch the engine off when driving.

1.1.5 Note on copyright

The texts, pictures and data contained in these converter guidelines are subject to copyright. This also applies to editions on CD-ROM, DVD or other media.

1.2 General information

The following pages contain technical guidelines for converters and equipment fitters on the design and assembly of bodies. The converter guidelines must be strictly adhered to when performing any modifications to the vehicle. The current version of the German edition of the converter guidelines is the exclusive authority for the most up-to-date information.

This also applies to legal claims. Should the converter guidelines include references to legal regulations, then no guarantee can be provided for the completeness and correctness of this content, or that it is up-to-date. Country-specific features can vary.

1.2.1 Product and vehicle information for converters

1.2.1.1 Contact in Germany

If you have questions concerning vehicle models from Volkswagen Commercial Vehicles, you can contact us via the internet portals of Volkswagen AG (www.customized-solution.com) or via one of the following methods:

Free hotline (from a German landline)	00 800-2878 66 49 33 (00 800-CUSTOMIZED)
Contact (email)	customizedsolution@volkswagen.de
Personal contacts	https://www.customized-solution.com/de/de/service-informationen/kundenbetreuung

1.2.1.2 International contact

Please contact the converter's support personnel at the responsible importer for technical advice relating to Volkswagen Commercial Vehicles models and as a point of contact for conversions.

To find the contact person responsible for you, please register on the Volkswagen AG CustomizedSolution portal (<https://www.customized-solution.com>).

Help is available for the registration option using the "Help" menu option.

International hotline	00-800-2878 66 49 33 (00-800-CUSTOMIZED)
Email	customizedsolution@volkswagen.de
Personal contacts	https://www.customized-solution.com/de/de/service-informationen/kundenbetreuung

1.2.1.3 Electronic repair and workshop information from Volkswagen AG (erWin*)

Converters can access repair and workshop information, e.g.:

- Current flow diagrams
- Workshop manuals
- Maintenance
- Self-study Programmes

via the Electronic Repair and Workshop Information System from Volkswagen AG (erWin*).

<http://erwin.volkswagen.de/erwin/showHome.do>

Converters with Integrated Partner or Premium Partner status have access to discounted annual licenses, which can be applied for in the Customised Solution portal under my Customised Solution Portal/Requirements/Planning and Development. For exporting, converters with Partner status receive information in this regard from their point of contact at the importer.

*Information system, subject to payment

1.2.1.4 Genuine Parts Online Ordering Portal*

For the purchase of spare parts and for the research of Volkswagen Genuine Parts, our latest parts catalogues are available on the Internet in the “Genuine Parts Online Ordering Portal”:

<http://www.partslink24.com>

*Information system, subject to payment

1.2.1.5 Online Owner’s Manual

Detailed information about the functions and handling of your vehicle can be found in your Owner’s Manual which is enclosed with your vehicle ex-works. In addition to the hard copy of the Owner’s Manual, the following link and VIN number of the vehicle can be used to receive the Owner’s Manual in electronic form.

<https://www.volkswagen-nutzfahrzeuge.de/de/service-und-teile/bordbuch.html>

1.2.1.6 European Type Approval (ETA) and EC Certificate of Conformity (CoC)

Directive (EU) 2018/858 of the European Parliament establishes the standard for the approval of motor vehicles and their trailers, and of systems, components and separate technical units intended for such vehicles.

Provisions were also adopted in these guidelines for the approval of vehicles produced in several stages: the multi-stage approval process. Accordingly, each manufacturer involved in the construction of a vehicle is itself responsible for the approval of modified or added scopes in its production stage.

The manufacturer may choose one of the four following methods:

- EU type approval (ETA)
- EU type approval for small series
- National small series type approval
- Individual approval

CoC = Certificate of Conformity. A document that verifies the conformity of certain goods – and therefore also of vehicles and bodies – in accordance with the recognised (international) standards. The purpose of this EC Certificate of Conformity is to facilitate the approval of goods on international markets. As a result, the document is needed above all in import and export as part of the customs clearance procedure.

The manufacturer, the owner of an EU type approval or EU small series type approval, is obliged to provide a Certificate of Conformity with every vehicle which corresponds to an approved type. If you are planning to apply multi-stage type approval, an agreement must be concluded in accordance with the 2018/858/EU regulation.

1.2.1.7 Worldwide Harmonized Light-Duty Vehicles Test Procedure (WLTP)

New consumption values/ranges calculated in accordance with the new WLTP standards apply from September 2017 for new passenger cars entering the market and from September 2018 for new light commercial vehicles entering the market.

As of 1 September 2018, certified WLTP measurements must be available for all newly registered passenger cars. For light commercial vehicles with exhaust emission standard Euro 6d under Regulation EC 715/2007, the regulation will come into force one year later on 1 September 2019.

28+6 markets in Europe are affected by the WLTP.

WLTP stands for Worldwide Harmonised Light Vehicles Test Procedure. This is a worldwide standardised testing procedure for determining fuel consumption/electric range and exhaust emissions.

It is replacing the NEDC (New European Driving Cycle) test procedure that has been in force since 1992.

Unlike the NEDC, the WLTP takes into account individual special equipment and conversion solutions for weight, aerodynamics, electrical system requirements (no-load current) and rolling resistance which have an impact on the fuel consumption/electric range and exhaust emissions. This includes, in particular, modifications that result in a larger end face, a different radiator inflow area, a higher kerb weight for the vehicle or changes to the tyre size or the rolling resistance. Special equipment that consumes power, such as the air conditioning system or seat heating, still remains switched off for the duration of the test procedure.

Before initial approval, conversions or add-ons where WLTP is relevant can be made if they are approved by way of an individual approval or multi-stage type approval.

The Volkswagen type approval can be used for the multi-stage type approval for vehicles with conversions or add-ons that remain within the ISC parameters* / maximum technical specifications for add-on parts. If the add-on or conversion is outside the ISC parameters* / maximum technical specifications defined by the manufacturer for add-on parts, the converter must demonstrate compliance with the exhaust gas emissions requirements / electric range.

Information about the ISC parameters* / maximum technical specifications for add-on parts can be found on the Volkswagen CustomizedSolution portal. Please ask your technical service/test centre for advice if you have questions about alternatives.

Some vehicles have speed limiters installed to ensure compliance with WLTP emissions regulations and road emissions requirements. If speed limiters have been installed to ensure compliance with emission regulations, they must not be manipulated. Deactivation is not possible.

To determine the consumption values of converted new vehicles in compliance with the WLTP procedure and to obtain a WLTP certification, the "WLTP Conversion Calculator" is available to you.

You can find more information as a Registered Converter on the CustomizedSolution portal / WLTP:

Germany / International: <https://www.customized-solution.com>

*ISC parameters (InServiceConformity parameters)

1.2.2 Converter guidelines, consulting

The converter guidelines define the technical requirements for custom converters and equipment fitters relating to the design and mounting of bodies for base vehicles of the Volkswagen Commercial Vehicles brand.

The converter guidelines must be strictly adhered to when performing any modifications to the vehicle.

The statutory requirements, technical vehicle regulations and guidelines stated in the Directive are not comprehensive. When making modifications to vehicles, all applicable statutory requirements and all technical vehicle regulations and guidelines must be observed. The work safety regulations of the trade association and the Machinery Directive must be observed.

Ensure that no modification adversely affects the functional reliability and safety of the running gear, the body or the electric system.

Modifications must only be performed by qualified specialists and in accordance with the generally acknowledged rules of the automotive industry.

Prerequisites for modifications to used vehicles:

The vehicle shall be in a good overall condition, i.e. structural parts such as longitudinal and cross members, pillars etc. shall not be corroded to such an extent that structural stability might be adversely affected.

Vehicles whose modifications might affect the validity of the general certificate of roadworthiness must be presented to an authorised testing centre for approval. It is recommended to clarify in advance with the relevant authority whether approval is required. Please contact us in case of inquiries for proposed modifications.

When inquiring about planned modifications, please enclose two sets of design drawings of the complete scope of the modification, including weights, centre of gravity and dimensions, which also clearly show how the body is attached to the chassis. Please use the online contact form for this ([see chapters 1.2.1.1 “Contact in Germany”](#) and [1.2.1.2 “International contact”](#)). Please also provide information about the intended operating conditions of the vehicle.

If bodies comply with the present converter guidelines, no additional approval by Volkswagen AG is required for the presentation of the vehicle at the relevant authority examining roadworthiness.

1.2.2.1 Letter of non-objection

Volkswagen AG does not issue body approvals for non-Volkswagen bodies. It merely provides converters with important information and technical specifications for dealing with the product in these guidelines. As a result, Volkswagen AG recommends that all work should be carried out on the basic vehicle and the body in accordance with the current Volkswagen converter guidelines applicable to the vehicle in question.

Volkswagen AG does not recommend body activities which

- are not conducted according to these Volkswagen converter guidelines
- exceed the gross vehicle weight rating
- exceed the gross axle weight rating

Volkswagen AG issues letters of non-objection on a voluntary basis, as follows:

The assessment conducted by Volkswagen AG is exclusively based on the documents submitted by the converter who is carrying out the modifications. The inspection and safety assessment only relate to the expressly designated scope of work, its basic compatibility with the designated chassis and its interfaces or, in the event of chassis modifications, the fundamental admissibility of the design for the designated chassis.

The safety certificate relates to the presented whole vehicle, and not

- To the design of the overall body,
- Its functions or
- The planned use.

Non-objection is only possible if the design, production and assembly are carried out by the converter performing the modifications in accordance with the current technology and in compliance with the applicable converter guidelines of Volkswagen AG – and assuming any deviations from these guidelines have been declared to be technically safe. The letter of non-objection does not release the converter who is performing the modifications from its responsibility for the product, or from its obligation to carry out its own calculations, tests and a trial of the entire vehicle in order to ensure that the operational safety, road safety and driving properties of the overall vehicle it has manufactured are acceptable. Accordingly, it is necessary to ensure that the converter exclusively accepts its responsibility for ensuring that its body activities are compatible with the basic vehicle as well as the operational and road safety of the vehicle. It is expressly stated that the letter of non-objection from Volkswagen AG does not represent a technical approval for the investigated changes.

In the course of assessment of a presented vehicle, an assessment report is written as a means of obtaining a letter of non-objection (LONO report).

The following assessment results are possible:

- Classified as “safe”
If the whole vehicle is classified as “safe”, the Sales department can subsequently issue the LONO certificate
- Classified as “not safe”
Classification as “not safe” in the individual categories:
 - + Basic vehicle configuration
 - + Impairment of the basic vehicle and possibly
 - + Sole body item

leads to a corresponding classification of the whole vehicle. This means no LONO certificate can be issued initially.

In order for a not-safe classification to be resolved, the LONO report states the necessary modification for each item in question. In order for the letter of non-objection to be obtained, these points will have to be addressed by the converter and documented in a clearly comprehensible manner in a report along the same lines as the LONO report. On the basis of this detailed report, it is possible for the desk-review assessment to be completed with a positive result.

Depending on the defective points, it may be necessary not only to provide documentation of the defect resolution but also for the vehicle from the first inspection to be presented again. The first report indicates if it will be necessary for a new assessment to be carried out on the vehicle.

The assessment report may also contain “notes/recommendations”.

Notes/recommendations are technical remarks which do not have any effect on the letter of non-objection. They should be regarded as advice and suggestions for further consideration to support the continuous improvement of the final product for the customer.

In addition, “notes/recommendations solely relating to the conversion” can also be formulated. The information and recommendations stated as “solely relating to the body/conversion” must be dealt with and documented before the vehicle can be included in the CustomizedSolution Portal (CSP).

Practical note

Country-specific laws, directives and approval regulations shall be observed!

1.2.2.2 Application for the letter of non-objection

Before starting any work on the vehicle, auditable technical documentation and drawings must be submitted to the responsible department as part of the letter of non-objection evaluation (see 1.2.1 “Product and vehicle information for converters”).

Speedy handling of the request requires:

- Documents preferably in standardised digital formats (e.g. PDF, DXF, STEP)
- Technical data and documentation should be complete

The following details must be included:

- Vehicle type
 - + Vehicle equipment (chassis, panel van, window van, etc.)
 - + Wheelbase
 - + Frame overhang
- Vehicle identification number (if already available)
- Any deviations from these converter guidelines must be indicated on all documentation
- Axle load calculation
- All data about dimensions, weight and centre of gravity (weighing certificate)
- Special operating conditions (e.g. poor road conditions, extreme dust, high altitude, or ambient temperature extremes)
- Certificates (e-registration, seat tensile test)
- Attachment of the body on the vehicle
- Subframe:
 - + Material and profiles
 - + Dimensions
 - + Type of profile
 - + Features of the subframe construction (profile modifications, additional reinforcements, offsets, etc.)
- Type of fixation for the body or add-ons to the vehicle frame (e.g. bolted connections)
 - + Position (in relation to vehicle chassis)
 - + Type
 - + Size
 - + Number
 - + Property class
 - + All fixation brackets on the vehicle frame must be used for bolted connections to the subframe or body
- Type of fixation for the body or add-ons to the vehicle frame (bolting, bonding, welding)
- Photographic documentation of the conversion
- All documents must clearly correlate with the conversion (e.g. drawings marked with allocated numbers)
- General (functional) description of deviations from the production vehicle, or added components
- Electric wiring diagram
 - + Details of the consumption of additional electrical equipment

Complete documentation avoids the need for clarification queries and accelerates the processing.

1.2.2.3 Legal entitlements

- There is no legal entitlement for a letter of non-objection to be issued
- Due to ongoing technical development and the information derived from this, Volkswagen AG is entitled to refuse a letter of non-objection even if a comparable certificate had been issued formerly
- The letter of non-objection can be restricted to individual vehicles
- The subsequent issue of a letter of non-objection may be refused for vehicles that have already been completed or delivered
- The converter is solely responsible for:
 - + The function and compatibility of its body activities with the basic vehicle
 - + Road safety and operational reliability
 - + All body building activities and installed parts

1.2.3 Warranty and product liability of the converter

The converter's or equipment fitter's warranty conditions apply to the converter's or equipment fitter's scope of supply. Therefore, warranty claims associated with complaints to this scope of supply cannot be made under the warranty conditions applicable to Volkswagen Commercial Vehicles.

Defects of bodies, installations and equipping provided by third parties as well as defects of the vehicle caused by the said bodies, installations or conversions are excluded from the Volkswagen warranty and also from the Volkswagen paint and body warranty. This also applies to accessories which were not installed and/or supplied by the vehicle manufacturer.

The converter or equipment fitter is solely responsible for the design and assembly of bodies and the execution of conversions.

All modifications must be documented by the converter or equipment fitter.

The converter is responsible for ensuring that all modifications it performs comply with the technical vehicle regulations, specifications and standards that apply in the countries of registration.

Due to the multitude of modifications and diversity of operating conditions, the information provided by Volkswagen AG is subject to the reservation that modified vehicles are not tested by Volkswagen AG. Modifications may affect the properties of the vehicle. For reasons of liability, the converters or fitters must provide the following information in writing to their customers. In individual cases, Volkswagen AG reserves the right to demand evidence of the information being passed on to the customer.

“Due to the modifications* to your Volkswagen Commercial Vehicles basic vehicle, the properties of your basic vehicle may have changed. Please understand that Volkswagen AG does not assume any liability for any negative effects resulting from the modifications* to the vehicle.”

No general legal entitlement for the approval of a body modification exists, even if such approval was previously granted. If bodies comply with the present guidelines, no additional approval by Volkswagen AG is required for the presentation of the vehicle at the relevant authority examining roadworthiness.

The converter's or equipment fitter's warranty conditions apply to the converter's or equipment fitter's scope of supply.

Therefore, warranty claims associated with complaints to this scope of supply cannot be made under the warranty conditions applicable to Volkswagen Commercial Vehicles.

UN ECE Regulation No. 155 for vehicle cyber security and UN ECE Regulation No. 156 for vehicle software updates apply to all new vehicle types from the middle of 2022 and to all new vehicle registrations from the middle of 2024; these contain new requirements for automotive cyber security and updates. Insofar as modifications are made to the vehicle, the converter shall also ensure that these regulations are applied and complied with.

* At this point, the term “modification” may be substituted by a more precise description of the work performed, e.g. by “camping equipment installation”, “wheelbase extension”, “box body”.

1.2.4 Ensuring traceability

Body dangers only detected after delivery can mean that subsequent measures in the market will be necessary (customer information, warning, call-back). To make these measures as efficient as possible, it is necessary to be able to trace the product after delivery. For this purpose, and in order to be able to use the central vehicle register (CVR) operated by the Federal Motor Transport Authority or comparable registers abroad for tracing the affected vehicle keepers, we strongly recommend that converters should store the serial number / identification number of their body linked to the vehicle identification number of the base vehicle in their databases. For this purpose, it is also recommended that customers' addresses are stored and that subsequent owners are provided with a means of registration.

1.2.5 Badges

VW badges and VW emblem are trademarks of Volkswagen AG. VW badges and VW emblems are not allowed to be removed without authorisation, or to be attached in a different location.

1.2.5.1 Positions on rear of the vehicle

VW badges and VW emblems which are enclosed in the delivery must be fitted in the location intended by Volkswagen.

1.2.5.2 Appearance of whole vehicle

If the vehicle does not correspond to the appearance and the quality requirements set by Volkswagen AG, then Volkswagen AG reserves the right to request removal of the Volkswagen AG trademarks.

1.2.5.3 Non-Volkswagen trademarks

Non-Volkswagen badges are not allowed to be attached next to Volkswagen badges.

1.2.6 Recommendations for vehicle storage

Extended storage times cannot always be avoided. The following measures are recommended to ensure that vehicle quality is not affected by long-term storage:

Carry out the following when the vehicle is delivered:

- Check on a weekly basis for aggressive deposits (e.g. bird droppings, industrial deposits) and clean if necessary
- 12-V battery: Determine the SOC* and, if necessary, complete the battery care programme (see the instructions "Carry out no later than every three months")
- High-voltage battery: Read the state of charge in the instrument cluster
If the charging indicator is in the red area. This means: $\leq 10\%$ or $< 1/4$ or < 50 km (depending on the display)
Charge the high-voltage battery until the display shows a maximum of half full
- Set the tyre pressure to 3.4 bar (not the spare wheel)
- Open all front vents in the dash panel, set the blower to maximum and run for one minute
- Remove any paper and other objects from the storage compartments and surfaces in the vehicle interior (dash panel, seats, luggage space) except for items that serve to protect the surfaces
- If fitted, roll in the luggage compartment cover and the sun blinds
- In addition, for new vehicles: Correct the position of the transport protective hoods if necessary
- Record the date of delivery as a reference for all vehicle care measures

*State of Charge

Carry out after no longer than six weeks:

- For vehicles stored without a solar panel:
Battery care programme (see “Carry out after no longer than three months”)
Do not disconnect the battery to do so!

Carry out after no longer than three months:

- Remove rust from brake disc
When storing vehicles without solar panels: complete the battery care programme
Do not disconnect the battery to do so!
- No battery status display in the dash panel insert:
Measure the open-circuit voltage of the 12 V battery two hours after the last electrical equipment was active
 - a) At an open-circuit voltage between 11.6 V and 12.5 V: Fully charge immediately
 - b) If the open-circuit voltage is <11.6 V: Mark and fully charge the defective battery
- The totally discharged battery must be replaced before the vehicle is handed over to the customer

Practical note

To determine the exact residual capacity of the 12 V battery, please proceed in accordance with the test conditions in the Workshop Manual.

Carry out after no longer than six months:

- For vehicles stored with a solar panel:
Carry out the battery maintenance programme (see “Carry out after no longer than three months”)
Do not disconnect the battery!

Practical note

When connecting a battery charger, the following connection specification must be observed under all circumstances:

- Positive: always connect to jump-start connection point, if fitted, otherwise to positive battery terminal
- Negative: always at the body earth provided for charging, as the direct connection of a battery charger to the negative terminal of the battery in some vehicles can lead to falsification of the battery status recording by the on-board electronics

Practical note

Charging the battery when it is installed is recommended.
Series and parallel charging of batteries is unauthorised.

For more information on the battery, see [chapter 4.2.1 “Battery information”](#).

Information

You can find further information about vehicle storage in the following documents:

- Owner's Manual ([see chapter 1.2.1.5 "Online Owner's Manual"](#))
- Vehicle care programme

1.2.7 Compliance with environmental rules and regulations

Environmental note

The following principles of environmentally friendly design and material selection should be followed right from the planning stage of add-ons or bodies, and the statutory requirements in the EU Directive on End-of-Life Vehicles 2000/53/EC should also be taken into account.

The converter is responsible for ensuring that all modifications it performs comply with the environmental regulations, specifications and standards that apply in the countries of registration and sale. These may go beyond the existing prerequisites of the basic vehicle and are the responsibility of the converter.

The converter must ensure that add-ons and bodies (conversions) comply with all applicable environmental rules and regulations, especially, but not only, EU directive 2000/53/EC concerning end-of-life vehicles and the REACH Regulation (EC) 1907/2006 relating to restrictions on the marketing and use of certain dangerous substances and preparations (“low flammability” and certain flame-retardant agents).

The registered keeper must keep all assembly documentation concerning the modification and hand it over together with the vehicle to the dismantler. This ensures that modified vehicles are processed in compliance with environmental rules and regulations at the end of their life cycle.

Materials which represent a potential risk such as halogen additives, heavy metals, asbestos, CFCs and chlorinated hydrocarbons shall be avoided.

Under environmental law, the converter must also ensure the following aspects. Please note that the following list merely contains examples and is not exhaustive:

- EU Directive 2000/53/EC must be adhered to
- Preferably, materials which allow valuable substance recycling and closed material cycles shall be used
- The material and production process shall be selected so that only low amounts of easily recyclable waste are generated
- Plastics shall only be used where these offer advantages in terms of cost, function or weight
- In the case of plastics, especially composite materials, only mutually compatible substances from one material family may be used
- With regard to components that are relevant for recycling, the number of plastic types used shall be kept as low as possible
- It is necessary to check whether a component can be manufactured from recycled material or with recycled additives
- Care shall be taken to ensure that recyclable components can be removed easily, e.g. by means of snap-lock connections, predetermined breaking points, good accessibility, use of standard tools
- Simple, environmentally friendly removal of the fluids shall be ensured by means of drain plugs etc.
- Wherever possible, the components shall not be painted or coated; instead, dyed plastic parts shall be used
- Components in areas at risk of accident shall be designed to be tolerant of damage, repairable and easy to exchange
- All plastic parts shall be identified according to the VDA material sheet 260 (“Components of motor vehicles; Identification of materials”), e.g. “PP-GF30R”

1.2.8 Recommendations for inspection, maintenance and repair

A service schedule outlining inspection and maintenance work must be provided for the modifications performed by the converter or equipment fitter. These instructions or schedules must include the maintenance and inspection intervals as well as the required operating fluids and materials and the spare parts. It is also important to specify parts and components with a limited service life which are to be checked at regular intervals in order to ensure service reliability and timely replacement where required.

This should be supported by a repair manual including tightening torques, settings and tolerances as well as other relevant specifications. Special tools, including their source of supply, must also be stated.

Converters/equipment fitters must also state which work may only be performed only by themselves or by their authorised workshops. If the converter's or equipment fitter's scope of supply includes electric, electronic, mechatronic, hydraulic or pneumatic systems, then current flow diagrams and diagnosis routines or similar documentation facilitating a systematic search for faults should be provided.

Please observe the Volkswagen AG Owner's Manual for the inspection, maintenance and repair of the basic vehicle.

Please only use brake fluids and engine oils approved by Volkswagen for your vehicle.

More information about brake fluids and engine oils can be found in the Owner's Manual for your vehicle:

<https://www.volkswagen-nutzfahrzeuge.de/de/service-und-teile/bordbuch.html>

(see also chapter 1.2.1.5 "Online Owner's Manual").

1.2.9 Accident prevention

Converters shall ensure that the bodies comply with applicable legal rules and regulations as well as all regulations regarding work safety and accident prevention. All safety rules and the information material provided by accident insurance providers shall be observed.

All technically feasible measures must be taken to prevent unsafe operation.

Country-specific laws, directives and approval regulations must be observed.

The converter is responsible for the compliance with these laws, rules and regulations.

For further information about commercial freight traffic in the Federal Republic of Germany please contact:

P.O. box address	Berufsgenossenschaft für Fahrzeughaltungen Fachausschuss "Verkehr" Sachgebiet "Fahrzeuge" Ottenser Hauptstrasse 54 D-22765 Hamburg
Telephone	+49 (0) 40 39 80 – 0
Fax	+49 (0) 40 39 80-19 99
Email	info@bgf.de
Home page	http://www.bgf.de

1.2.10 Quality system

Worldwide competition, increased quality requirements placed on the overall product by customers, national and international product liability legislation, new forms of organisation and increasing pressure on costs are demanding effective quality assurance systems in all areas of the automotive industry.

The requirements of a quality management system of this kind are described in DIN EN ISO 9001.

For the reasons stated above, Volkswagen AG strongly recommends that all converters should set up and maintain a quality management system with the following minimum requirements:

Definition of responsibilities and authorisations including organisational plan.

- Description of the processes and procedures
- Appointment of quality management representative
- Performing contract and build feasibility checks
- Performing product checks based on specified instructions
- Regulating the handling of faulty products
- Documentation and archiving of test results
- Ensuring the quality records of employees are up to date
- Systematic monitoring of test equipment
- Systematic material and parts identification
- Performing quality assurance measures at the suppliers
- Ensuring the availability of process, working and test instructions, and that they are up to date, in the departments and in the workplace

1.3 Planning bodies

Practical note

In addition to a user and maintenance friendly design, the right choice of materials and therefore observance of corrosion protection measures are important during the planning of bodies (see chapter 5.4 “Corrosion protection”).

1.3.1 Selecting the basic vehicle

The base vehicle needs to be selected carefully to ensure safe use in the respective field and usage profile.

When planning, please consider the following for the use in question:

- Wheelbase
- Engine/gearbox
- Final drive ratio
- Gross vehicle weight rating
- Centre of gravity
- Electrics – scope
- Optional extras required for the conversion

Practical note

Before carrying out body building or conversion measures, the supplied base vehicle should be checked with regard to the fulfilment of applicable requirements.

Information

In order to enable the vehicle to be homologated after the installation of conversions and installations, it is essential to select the additional equipment **PR no. 5EK** "Conversions (ISC parameter calculations possible)". This selection, however, also includes a limiting of the maximum speed to 130 km/h, which cannot be deactivated. An increased CO₂ value is noted in the vehicle registration. There are two engine/gearbox versions available. See chapter 8.1 "Notes on homologation of modifications and conversions". When ordering the vehicle, please contact your Volkswagen Commercial Vehicles partner for advice on the required additional equipment. Information on homologation after the conversion can be obtained from your responsible technical service.

Please note:

A return to the "standard homologation" **PR no. 5EA** option "without conversions" is not possible at a later time.

On the Volkswagen AG homepage, you can put together your vehicle using the configurator and view the special equipment available:

<https://www.volkswagen-nutzfahrzeuge.de/de/modelle.html>

The options for add-ons and bodies are currently only visible to Volkswagen Commercial Vehicles partners.

Information

V6 diesel engines are not suitable for multi-stage conversion if the emission values of the base vehicle are to be used. The WLTP calculator is not applicable here.

1.3.2 Vehicle modifications

Before starting work on the body, the converter should check whether

- the vehicle is suitable for the planned body
- the chassis type and the equipment also correspond with the operating conditions after the conversion

Build dimension drawings, product information and technical data can be obtained from the responsible department or via the communication system for the planning of bodies (see chapters 1.2.1.1 "Contact in Germany", 1.2.1.2 "International contact" and 1.2.2 "Converter guidelines, consulting").

Furthermore, the special equipment available from the factory should be noted (see chapter 1.4 "Special equipment").

Vehicles delivered from the factory comply with European directives and the national laws (except for some vehicles for countries outside Europe).

The vehicles also need to meet the European directives and the national laws after the modifications have been made.

Information

Please note that a majority of the EC directives announced to date have been annulled by Regulation (EC) 661/2009 "General Safety". The EC directives have been replaced by new EU directives or UNECE regulations with the same corresponding content.

Practical note

Sufficient space must be provided in order to guarantee the function and operating safety of the power units.

Warning note

Do not modify the steering or brake system! Modifications to the steering and brake system can result in these systems no longer working correctly and failing. This may result in the driver losing control of the vehicle and causing an accident.

Practical note

Modifications to the noise encapsulation can have effects which are relevant to registration.

1.3.3 Vehicle acceptance

The officially recognised appraiser or tester from the converter must be informed about modifications to the chassis.

Practical note

Country-specific laws, directives and approval regulations shall be observed!

1.4 Special equipment

We recommend using the special equipment from Volkswagen AG that can be obtained with a PR number for optimum adaptation of the body to the vehicle.

You can obtain information on special equipment provided by Volkswagen under PR numbers from your Volkswagen dealership, your importer or in your contact options for product and vehicle information for converters (see chapter 1.2.1 “Product and vehicle information for converters”).

Information

You can also put together your vehicle in the configurator on the Volkswagen AG homepage and view the special equipment available:

<https://www.volkswagen-nutzfahrzeuge.de/de/modelle.html>

Special equipment (e.g. frame reinforcements, anti-roll bars etc.) or equipment fitted later increase the kerb weight of the vehicle. The actual vehicle weight and the axle loads should be determined and documented by weighing before and after the conversion. Not all additional equipment can be installed into every vehicle without problems. This applies in particular if it is fitted later on.

1.5 Commercial aspects

1.5.1 Restraint system

Warning note

- Changes to the restraint system are not permissible
- Airbags are explosive. Handling, transport and storage of airbags are subject to legislation on potentially explosive substances, and the responsible public authority or government agency shall therefore be notified. Purchase, transport, storage, installation and removal as well as disposal are only allowed to be performed by trained staff in accordance with the corresponding safety regulations
- Do not alter, modify or relocate the airbag, the restraint system's sensor and modules, or any of its components
- Attachments or modifications to the front of the vehicle may have an adverse effect on the timing of airbag triggering and result in unsafe deployment of safety equipment
- See also [chapter 5.2 "Airbag systems"](#)

1.5.2 Drilling and welding

Drilling and welding of the frame and body must be carried out in accordance with the guidelines in this document.

1.5.3 Minimum requirements for the brake system

Modifications to the anti-lock brake system (ABS), traction control system (TCS) and electronic stability control (ESC), electronic brake servo (EBB) and driver assistance technologies are not permitted.

1.5.4 Road safety

The respective instructions should be strictly followed to ensure operational and road safety of the vehicle.

1.6 Electromagnetic compatibility (EMC)

Warning note

- Do not secure aerial cables to the vehicle's original wiring, to fuel lines or to brake lines
- Keep aerial and power cables at least 10 cm (4 inches) away from electronic modules and airbags

Information

- Your vehicle has been tested and certified for electromagnetic compatibility by us in accordance with legal requirements
- It is the responsibility of the converter to ensure that all equipment installed in the vehicle complies with applicable local laws and other requirements. Installation of some aftermarket electronic devices could affect the performance of vehicle functions that use radio frequency signals such as broadcast receivers, tyre pressure monitoring system, pushbutton start, Bluetooth connectivity or satellite navigation
- All radio frequency transmitters in your vehicle (e.g. mobile phones and amateur radio transmitters) must comply with the parameters in the following figures and tables. We do not stipulate any other special terms or conditions for installations or use

1.6.1 Pickup

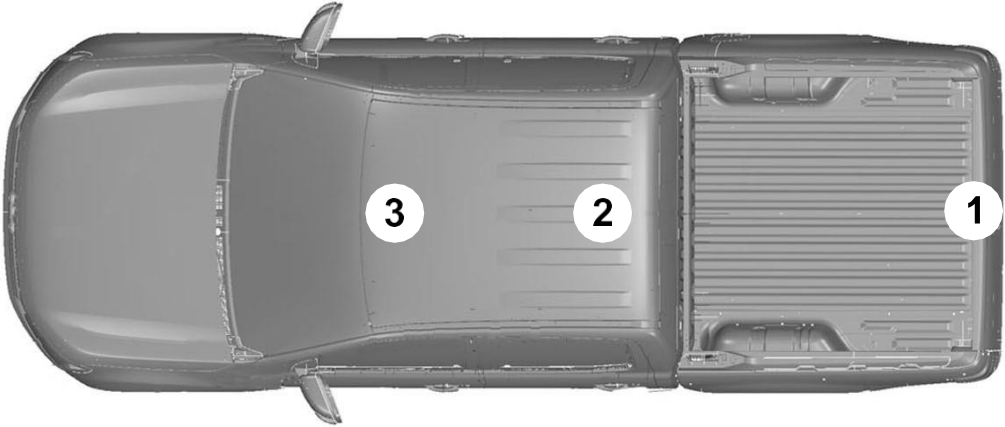

MHz frequency band	Maximum output power in watts (Peak RMS)	Aerial position
1–30	50	1
50–54	50	2, 3
68–88	50	2, 3
142–176	50	2, 3
380–512	50	2, 3
806–870	10	2, 3

1.7 Raising the vehicle with a jack

Warning note

- Ensure that the jack's screw thread is adequately lubricated before use
- If possible, the socket should be used on level, solid ground
- Turn off the ignition and fully apply the electromechanical parking brake before raising the vehicle
- The jack supplied with this vehicle is for changing wheels only
- Use the jack only when changing a wheel in an emergency
- See the Owner's Manual for the procedure and jacking points on all vehicle versions

Practical note

When converting the vehicle, make sure that access to the spare wheel is not blocked. Ensure that sufficient clearance remains for successful lowering and raising of the spare wheel. Failure to comply with this requirement may result in damage to the winch mechanism and unsafe position of the spare wheel.

Information

- When using the vehicle jack, read the Owner's Manual for information on proper use.
- The spare wheel winch is located above the spare wheel and is accessible from the rear of the chassis frame
- The jack must be mounted and secured to the vehicle appropriately to ensure safety, durability, and accessibility

Warning note

When raising the vehicle with the jack, for your own safety, never get under the vehicle.



1.7.1 Vehicle jacking points and axle stand positions

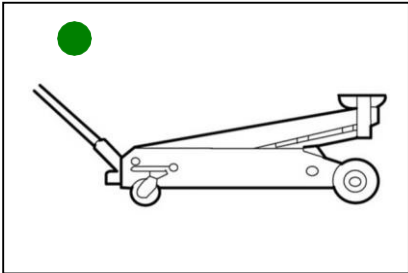
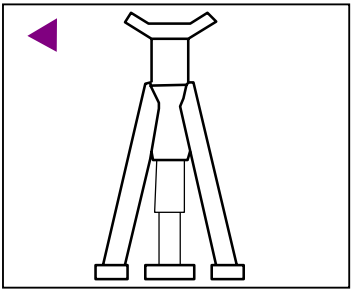
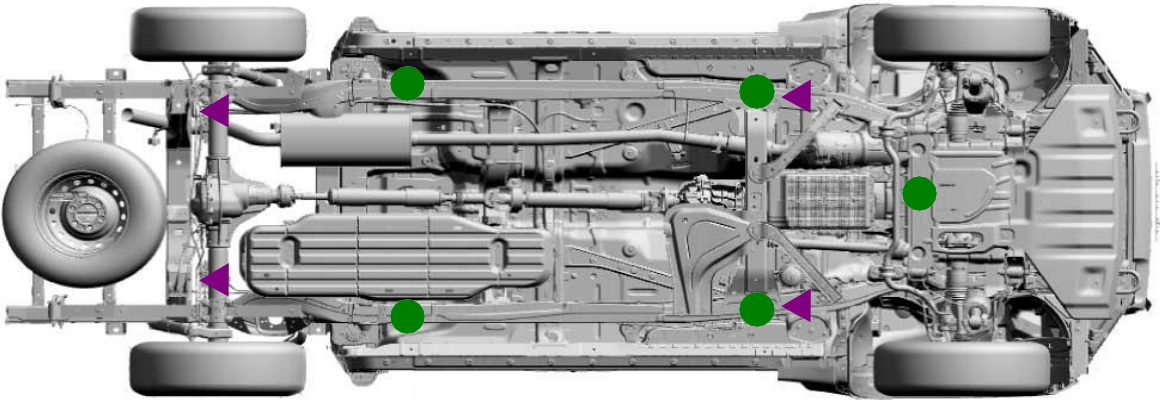

1.8 Raising the vehicle with a lifting platform

Warning note

When raising the vehicle with a two-pillar lifting platform to remove the engine/gearbox or rear axle, make sure the vehicle is secured to the hoist with vehicle restraint straps to prevent tipping. Failure to comply with these instructions could result in serious injuries.

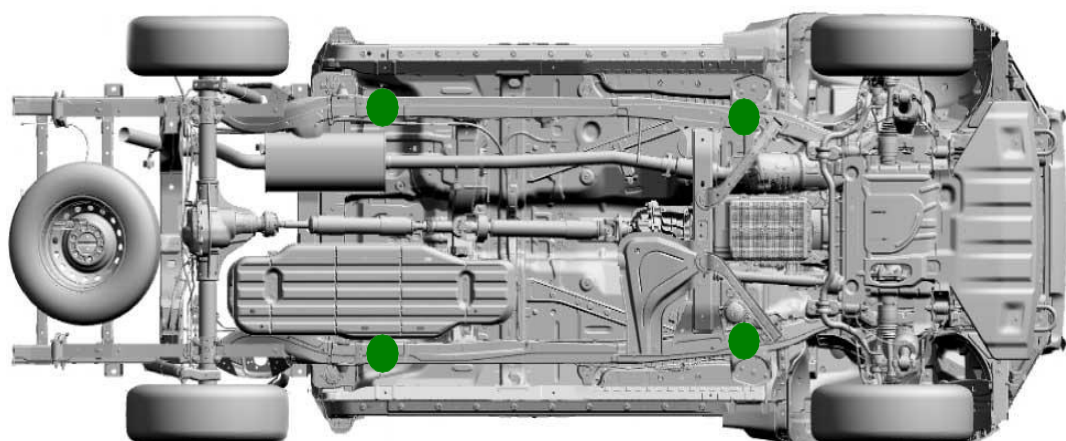

All vehicles

Practical note

- When raising the vehicle with a two-pillar lifting platform, vehicle lift arm adapters must be used under the lifting points
- When raising the vehicle with a two-pillar lifting platform, do not exceed the maximum kerb weight
- It is important that only the correct lifting and support locations are used at all times

Warning note

Ensure that the modified vehicle meets all relevant regulatory requirements.

Practical note

Ensure that the diesel fuel filter (if fitted) under the vehicle floor in front of the gearbox cross member is not damaged. If care is not taken when placing the lifting bags, the fuel system may be damaged.

1.9 Noise, vibration and harshness (NVH)

Modifications to the drive train, engine, gearbox, exhaust gas, air intake system or tyres can affect exterior noise emissions. For this reason, the exterior noise level of the modified vehicle must be verified.

The interior noise level should not be worsened by the conversion. Reinforce panels and structures as needed to prevent vibration.

Consider the use of sound deadening material on panels.

1.10 Vehicle transport aids and vehicle storage

Practical note

- Disconnect the battery if the vehicle will not be moved for more than 30 days
- Ensure that protectors are not removed from an incomplete vehicle until the conversion has begun
- Make sure that components removed during the conversion are kept clean and dry
- Ensure that components removed during the conversion are reinstalled in the same vehicle

In addition:

Raise the wipers and position them away from the windscreen.

All air intakes should be closed.

Increase the normal tyre pressure by 0.5 bar / 7.25 psi / 50 kPa.

The handbrake system should not be used.

Apply appropriate wheel chocks to prevent rolling.

Deterioration of the vehicle body is a significant risk during storage, so proper storage procedures must be followed, including regular inspections and maintenance.

Claims arising from deterioration caused by improper storage, maintenance or handling will not be the responsibility of Volkswagen AG.

Vehicle processors must establish their own procedures and precautions, especially when vehicles are stored outdoors, as they are exposed to any number of airborne contaminants.

The following may be considered a reasonable approach to storage:

Short-term storage:

Where possible, vehicles should be stored in an enclosed, dry, well-ventilated area based on firm, well-drained ground that is free of long grass or weeds and, where possible, protected from direct sunlight.

Vehicles should not be parked near trees or near water, as additional protection may be required for certain areas.

Long-term storage:

The battery should be disconnected but not removed from the vehicle.

The wiper blades should be removed and placed in the vehicle. Ensure that the wiper arms are suitably restrained from resting against the windscreen.

Engage a gear and fully release the parking brake. Secure the wheels with wheel chocks if the vehicle is not parked on level ground.

Set the climate control to the "open" position to provide ventilation where possible.

If protective film was applied during manufacture, it must be left on the vehicle until it is made ready for delivery, but it must be removed after a storage period of six months at the most (the film is date stamped to indicate the required removal date).

Ensure that all windows, doors, the bonnet, rear lid and luggage compartment lid are fully closed and the vehicle is locked.

The handover inspection (PDI) is the final opportunity to ensure a battery is fit for purpose before the customer takes delivery of their new vehicle. Prior to handover of the vehicle to the customer, the battery must be inspected and appropriate action taken. The results of the inspection must be recorded on the PDI repair order.

Batteries:

To ensure that the battery is properly maintained and to prevent premature failure, it is necessary to periodically check and charge the battery while a vehicle is not in use.

Leaving a battery below its optimum state of charge for an extended period of time can cause premature battery failure.

To reduce the probability of premature battery failure, we recommend:

Keeping the battery connected – monthly controls should be carried out.

Disconnecting the battery – a three-month check should be carried out.

Action / time in storage	Monthly	Every 3 months
Check that the vehicle is clean	x	-
Remove external contaminants	x	-
Check battery condition and recharge if necessary	Connected	Disconnected
Visually inspect tyres	x	-
Check for condensation in the vehicle interior	-	x
Run the engine until the coolant gauge reaches temperature (60°C) with the air conditioning system on, if applicable	-	x

1.11 Assemblies and ergonomics

1.11.1 General guidelines for assemblies

The converter must ensure that adequate clearance is maintained from moving components such as axles, fans, steering, brake system etc. under all drive conditions.

The converter is responsible for all installed components during the conversion. Durability must be confirmed by appropriate test procedures .

Warning note

Do not modify, drill, cut or weld any suspension components, especially the steering gear system, subframe or anti-roll bars, springs or shock absorbers including mounting brackets.

1.11.2 Driver's operating area

Controls and/or equipment used while driving should be within the driver's reach, otherwise the driver may lose control of the vehicle and cause an accident.

1.11.3 Driver's field of vision

Warning note

Ensure that the modified vehicle meets all relevant regulatory requirements.

1.11.4 Effects of conversions on parking aids

Warning note

Monitors that are retrofitted in the cab should correspond to the interior package and the safety requirements.

If a reversing camera is installed during conversions, the required reversing signal can be taken as described in the section on reversing lights. For more information, see [chapter 4.6.8](#).

1.11.5 Aids for entering and exiting vehicles

Steps

Practical note

- Ensure that reinforcements are installed so as to maintain the strength of the original body structure.
- Ensure that the modified vehicle meets all relevant regulatory requirements
- If the conversion changes the type-approved dimensions, a new type approval must be obtained

On some derivatives of the Amarok, steps are part of the basic equipment or can be ordered as optional equipment. Please check for availability.

If additional or alternative steps are installed, the required ground clearance must be observed.

The converter must ensure that a movable step automatically assumes the driving position as soon as the vehicle is moved. The tread surface of the step must be non-slip.

Exterior mirror

Information

- The overall width of the Amarok with the exterior rear view mirrors extended is 2208 mm
- The maximum vehicle width (X) is 1910 mm

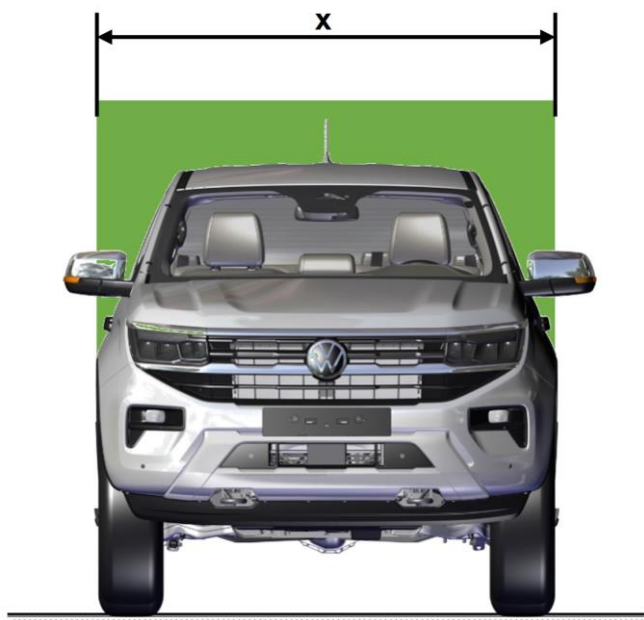

1.11.6 Worldwide Harmonised Light Vehicles Test Procedure (WLTP) calculation inputs

Information

Specifications and measured values must be observed for the WLTP calculation for vehicles with conversions. See also the information in [chapter 1.11.12 “WLTP front area calculation”](#) and [chapter 8 “Homologation”](#).

In cooperation with the relevant importer, please check whether the information in these guidelines also applies to the type approval in your market.

1.11.7 Mass of the finished vehicle

All modifications and changes that affect the actual mass of the vehicle must be taken into account. The definition of actual mass is set out in the provisions of Regulation 2018/1832 Annex XXI.

The actual mass of the finished vehicle must be specified for the front and rear axles. This weight distribution is important if the finished vehicle has mixed tyres between front and rear.

1.11.8 Frontal surface

All modifications and changes that affect the front surface of the finished vehicle must be taken into account. For more information, see later in this section.

1.11.9 Rolling resistance of tyres

Modifications to the tyres installed on the finished vehicle must be accounted for. The efficiency class and tyre class are needed to determine the correct calculation. This can be found on the tyre label according to the following example.

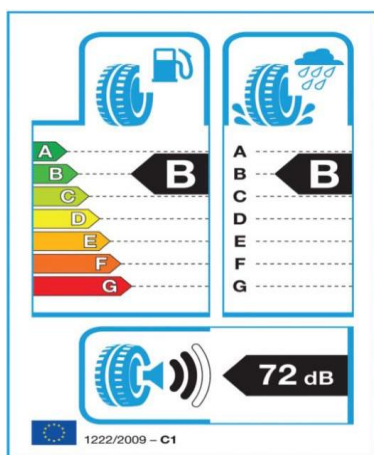

Exceeding attribute limits

If the converter wishes to make use of the base vehicle approval, the converter must stay within the limits defined in the converter guidelines and the emission type approval applicable to the vehicle. It is the responsibility of the converter to ensure compliance with these defined limits in order to maintain emissions performance. If converters wish to exceed the limits, they must seek clarification from the relevant technical service or type approval authority. In this case, the base approval may become invalid and the converter may have to recertify the vehicle against the exceeded limits.

1.11.10 Key to vehicle dimensions

General information

Dimensions (mm)	Vehicles with increased ride height (4x2 / 4x4)	Vehicles with low ride height (4x2)
Wheelbase length	3,270	3,270
Total vehicle height at base kerb weight – measured at aerial base		
Double cab	1,875–1,887	1,780
Total vehicle height – measured at aerial base with MAX rear axle load		
Double cab	1,805–1,817	1,707

All dimensions are subject to manufacturing tolerances and refer to minimum specification models and do not include additional equipment. Height dimensions show the range for minimum to maximum weight range and are for reference only.

1.11.11 Recommended main load range dimensions

Vehicle	A (mm)	B (mm)	C (mm)
Double cab	2,104	2,214	755

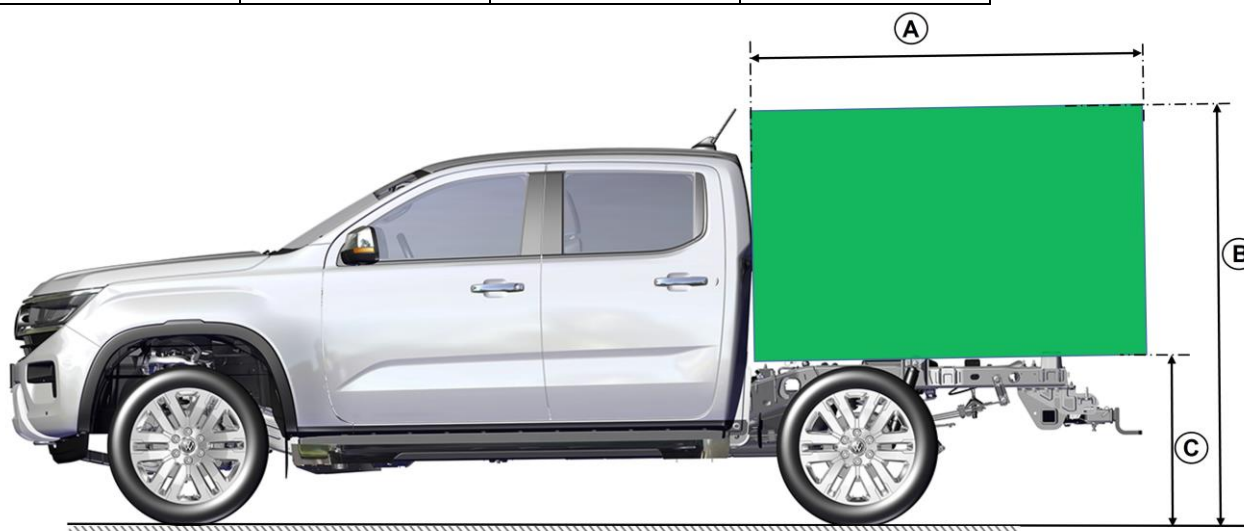

1.11.12 WLTP front area calculation

Information

In order to determine the WLTP values required for type approval, data must be entered into the Volkswagen Commercial Vehicles WLTP calculator. See [chapter “1.2.1.7 Worldwide Harmonised Light Vehicles Test Procedure”](#).

The ISC parameters for the maximum permissible front area, the required radiator entry surface, the masses when the vehicle is ready to drive and the permissible rolling resistances of the tyres can be found in [chapter 8.1 “Notes on homologation of modifications and conversions”](#). If the optional equipment **PR no. 5EK** “Conversions (ISC parameter calculations possible)” was selected, the ISC parameters can also be found in the configurator at your Commercial Vehicles partner or importer. You can also obtain this information from your local technical service.

All standard and optional equipment has already been taken into account. In other words, the vehicle frontal area of the base vehicle including the mirrors.

Calculating the frontal area

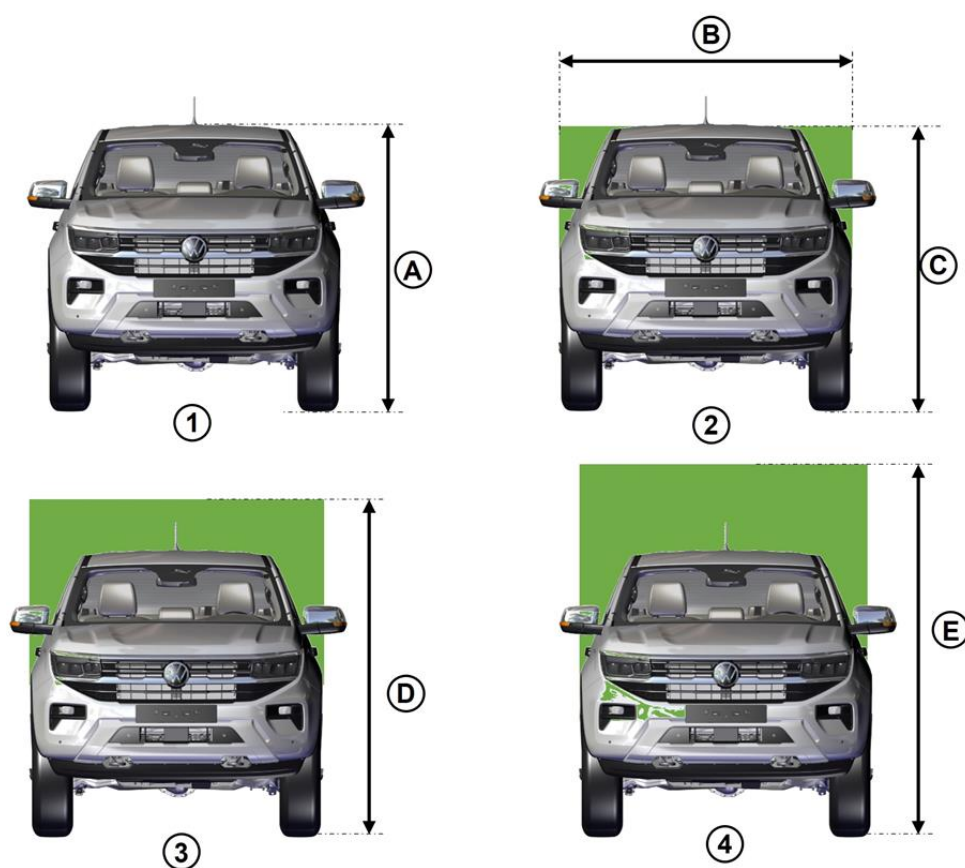

Item	Description
1	Base vehicle
2	Box in cab width and roof height as on base vehicle
3	Box 0.5 m ² larger than frontal area of base vehicle
4	The box is 1 m ² larger than the front surface of the base vehicle

Dimension of the end face of the vehicle

Measurement	mm
A	1,820 (measured from the road surface to the roof surface)
B	1,860
C	1,839
D	1,945
E	2,214

Configuration of the front area of the vehicle

Calculation examples for determining the front surface

Front area of the vehicle	A) Base vehicle + body [m ²]	A1) Additional surface due to body [m ²]
1 = base vehicle	2.873	-
2 = box in cab width and roof height as on base vehicle	3.175	0.302
3 = area of box approx. 0.5 m ² larger than front area of base vehicle	3.373	0.500
4 = area of box approx. 1 m ² larger than front area of base vehicle	3.873	1.000

Information

The figures shown above are examples of how to roughly determine how the front surface has changed due to the body. The converter only has to determine the front surface of the mounted unit, for example (BxC), and compare the values with the table. Additional fixed structures such as brackets and signalling and lighting systems shall also be taken into account when determining the front surface.

If the structure lies within the dimensions shown above, it can be assumed that values for the maximum permissible front surface are complied with. However, a check by entering the actual dimensions in the WLTP calculator is required.

Caution: When selecting the maximum width of the body, it is essential to consider the view from the exterior mirror towards the rear. See the specifications in [chapter 1.11.5 "Aids for entering and exiting vehicles"](#)

1.11.13 Number plate

Front number plate:

Warning note

- The attachment of a number plate to the front of the vehicle must comply with local regulations
- No part of a motor vehicle registration number shall be obscured by standard equipment, regular production options, or equipment in accordance with local regulations

The number plate shall be mounted on the front of the vehicle forward of and parallel to the front “axle” so that no part of the number plate is more than 1,300 mm above the ground.

Rear number plate:

Warning note

- The attachment of a number plate to the rear of the vehicle must comply with local regulations
- No part of a motor vehicle registration number shall be obscured by standard equipment, regular production options, or equipment in accordance with local regulations

The number plate shall be mounted on the rear of the vehicle so that no part of the number plate is more than 1,300 mm above the ground.

1.12 Assemblies and ergonomics – specifications

1.12.1 Recommended body dimensions

Warning note

- Vehicles equipped with Electronic Stability Control (ESC) must not have the wheelbase modified or any type of frame extension
- Ensure that the mass added to the vehicle does not have an adverse effect on vehicle stability

Information

- Extreme rear overhang can result in unacceptable loading conditions, which can reduce the load on the front axle and result in unacceptable handling and braking characteristics. Ensure that the centre of gravity of the body and payload are not outside the recommended range
- An excessively high centre of gravity could affect vehicle stability. Make sure that the centre of gravity of the body and the payload is not outside the recommended range
(See also chapter 5.1 “Body”)
- If there is a frame extension behind the rear axle, we recommend limiting the total rear overhang to a maximum of 50% of the vehicle wheelbase
- If a ball coupling is attached to the vehicle, the body dimensions must include a clearance zone for ball couplings in accordance with local statutory requirements
- If the conversion requires an overhang of more than 50%, please contact your importer or our customer support (see chapter 1.2.1.1 “Contact in Germany”, 1.2.1.2 “International contact”).
- An additional extension rod is required in order to access the wheel winch with a longer sump overhang. The extension rod can be purchased from your Volkswagen Commercial Vehicles Partner under part number 2HJ.011.045.A.

Information

- Load-bearing structures should not be mounted on an existing cargo box. Mounting points for the body are provided on the frame
(See also [chapter 5.1 “Body”](#))

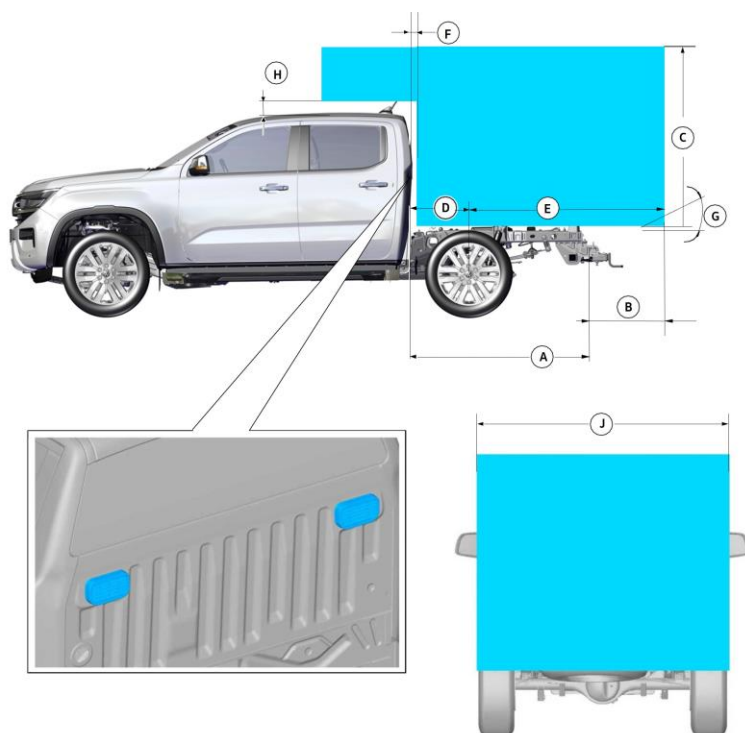

Description		Dimensions (mm)
		Double cab
A	Frame length behind the rear of the cab (without tail light cross member)	1518 mm
B	Legislation on underbody bars and towing devices must be complied with	
C	Maximum recommended exterior vehicle size*	2,400 above top of frame, provided load distribution requirements are met
D	Centre line from front outside of body to rear axle	497 mm
E	Maximum recommended rear overhang	(50% of vehicle wheelbase), provided load distribution requirements are met
F	Distance between the rear of the cab and the vehicle body	At least 28 mm
G	Ensure that local lighting laws are complied with. See also: Exterior lighting (chapter 4.6).	
H	Distance between the top of the cab and the vehicle body	30 mm
J	Maximum exterior vehicle width (without side step)	1,910

*For WLTP markets, these dimensions should be disregarded. Refer to the relevant WLTP dimensions. See also [chapter 1.11 “Assemblies and ergonomics”](#).

All dimensions (shown in mm) are subject to manufacturing tolerances and refer to minimum specification models that do not include additional equipment. The illustrations are for orientation purposes only.

1.12.2 Technical data for planning/base vehicle

Double cab 4x2 and 4x4

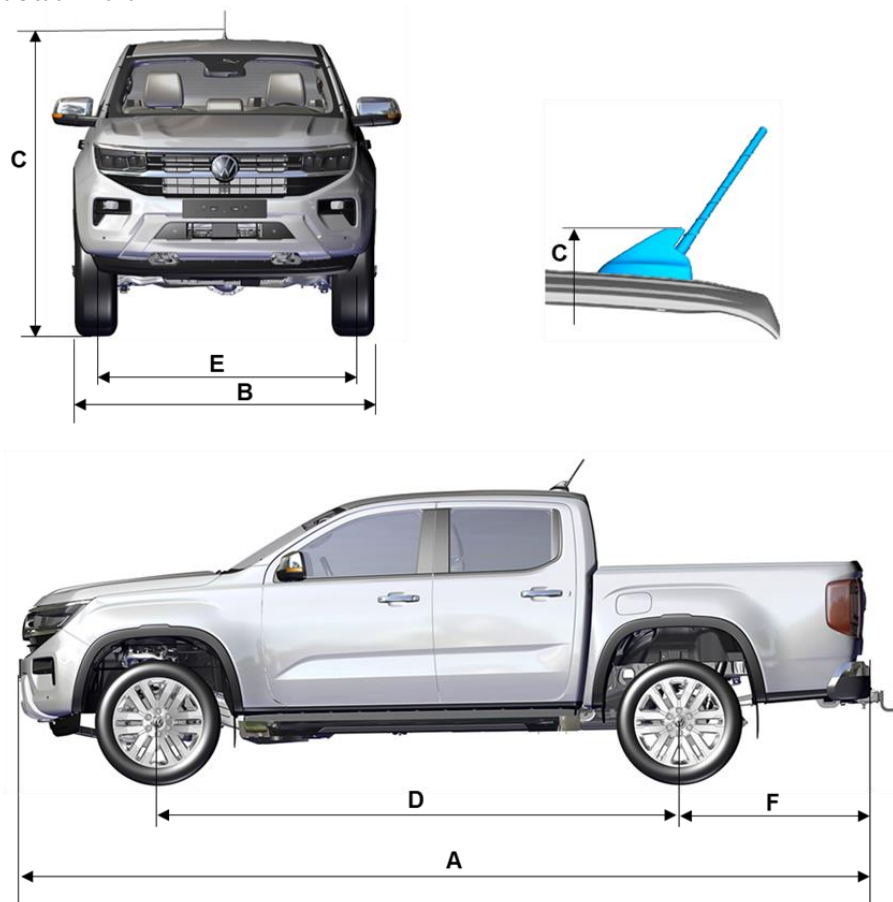

Basic data – vehicle dimensions

Description		Double cab [mm]
A	Vehicle length including bumper	5,350
	Vehicle length with number plate	5,362
	Vehicle length with mounting plate for towing bracket	5,390
	Vehicle length with towing bracket	5,545
B	Vehicle width – without exterior mirror	1,910
	Vehicle width with step	1,917
C	Total height from base to roof (unloaded)	1,871
	Total height to aerial base (unloaded)	1,884
	Total height to roof railing (unloaded)	1,878
	Total height to aerial tip (unloaded)	2,079
D	Wheelbase	3,270
E	Track	1,620
F	Rear overhang (with rear bumper, without towing bracket)	1,211

1.12.3 Unladen mass and payload

Warning note

Check the approval requirements and legal requirements applicable in the market.

Details on vehicle kerb mass and payload capacities can be provided by your Volkswagen Commercial Vehicles partner or importer.

1.12.4 Gross vehicle mass and axle load

Warning note

Check the approval requirements and legal requirements applicable in the market.

Details on the axle loads for your vehicle can be provided by your Volkswagen Commercial Vehicles partner or importer.

1.12.5 Front, rear and side skid plate

Warning note

Check the approval requirements and legal requirements applicable in the market.

The front skid plate, rear skid plate and side skid plate must be designed in accordance with the approval regulations and legal requirements applicable on the market.

1.12.6 Rear skid plate – chassis with cab

Warning note

Check the approval requirements and legal requirements applicable in the market.

The rear underbody protection must be designed in accordance with the ECE 58 directive or in accordance with the approval regulations and legal requirements applicable on the market.

1.13 Components – specifications

Material specification, strength and torque

Standard material and tightening torques (Nm) for screws/bolts: ISO 898-1, nuts: ISO 898-2						
	Category 4.8		Category 8.8		Category 10.9	
Thread size	Minimum	Maximum	Minimum	Maximum	Minimum	Maximum
A4	1.1	1.4	2.4	3.4		
M5	2.2	2.7	4.9	6.7		
M6	3.7	4.7	8.5	11.5	11	15
M8			20	28	25	35
M10			41	55	50	70
M12			68	92	95	125
M14			113	153	150	200
M16			170	230	230	310
A18			250	315	315	400
A20			345	430	435	540
A22			470	590	590	745
M24			600	750	755	945

This torque table is a recommendation. The converter is responsible for the optimum tightening torque for the mounted components. For a specific vehicle torque specification, refer to the corresponding VW Commercial Vehicles workshop manual or contact your local Volkswagen Commercial Vehicles partner or importer.

1.14 Load distribution – specifications

1.14.1 Load distribution calculations – weight distribution of driver and front passenger

Practical note

- Do not exceed the gross axle weight ratings
- Do not exceed the permissible total mass of the vehicle
- The tyre manufacturer's specifications must be complied with

Information

- Uneven load distribution may result in unacceptable handling and braking characteristics
- Overloading the vehicle may result in unacceptable ground clearance
- The centre of mass of the body and the payload it contains should be within the specified dimensions
- Avoid one-sided load distribution
- For further information, please contact your local Volkswagen Commercial Vehicles partner or importer

DoubleCab

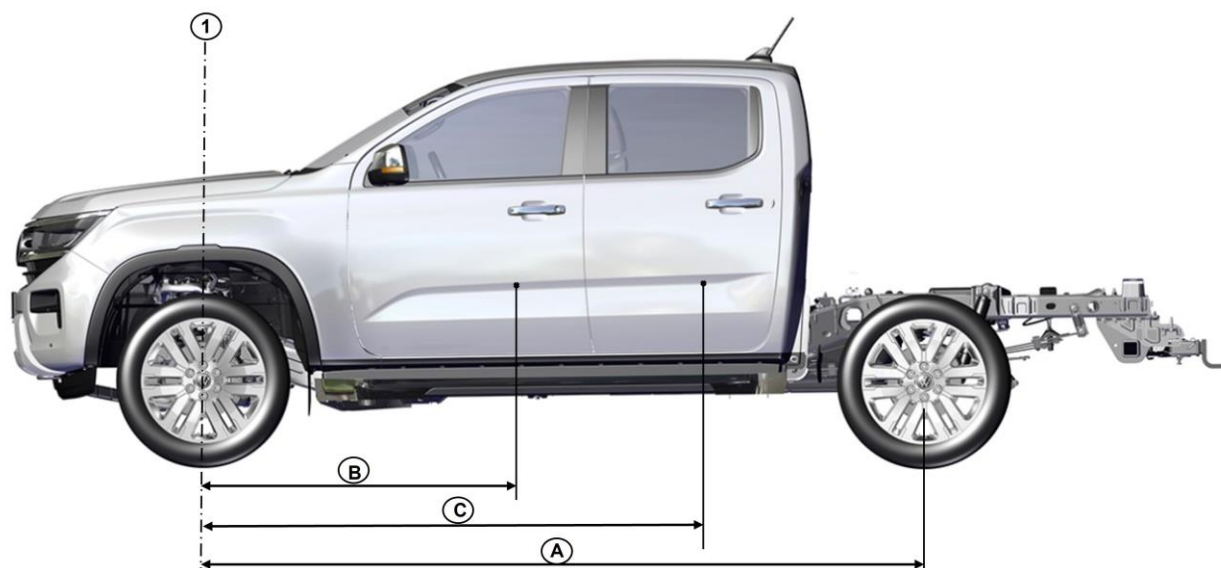

Weight distribution for driver and front passenger (vehicle with DoubleCab)

"A" wheelbase (mm)	"B" front seats and driver (mm)	"C" second row seats (mm)	Weight distribution per person (kg)		
			On the front axle	On the rear axle	Total
3,270	1,540	-	40	35	75
	-	2,360	21	54	75

1.14.2 Centre of gravity

Information

- The calculations specified here do not include the towing bracket and other accessories fitted by the converter
- "Additional mass" includes all additional equipment and cargo, but excludes passengers seated in standard cabs
- For double cab vehicles, there is a limit to the additional mass that must be considered, in addition to not exceeding the gross axle and towing weights

DoubleCab

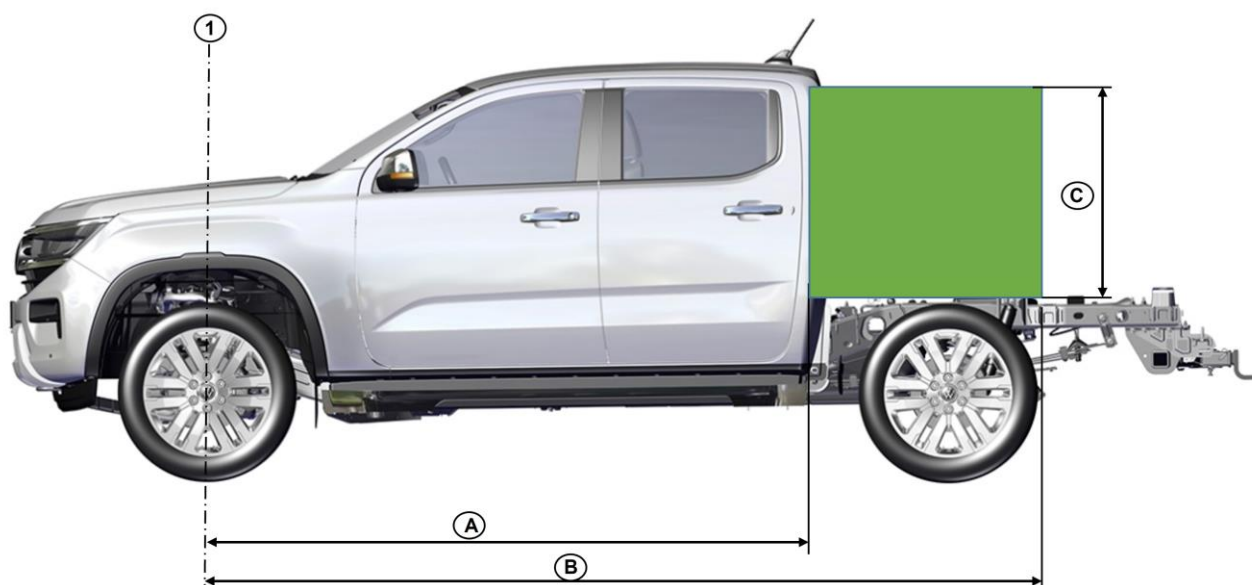

Critical focus of the double cab

Model	Recommended centre of gravity position for additional mass		
	'A' min (mm)	'B' max (mm)	'C' max (mm)**
4x2	-	3,615	740
4x2*	2,435	3,615	590
4x4	2,435	3,615	590

*4x2 vehicles with increased ride height.

**Dimension 'C' is taken from the body fasteners.

1.15 Towing brackets

1.15.1 Requirements for the towing brackets

If a towing bracket needs to be retrofitted, the converter should use a Volkswagen-approved bracket.

1.15.2 Use of the towing bracket

Warning note

- Do not exceed the total mass or maximum trailer weight specified for your vehicle. Refer to your vehicle Owner's Manual for maximum trailer weight specifications
- Ensure that the drawbar load of the towing bracket is within the specified range
- Towing trailers that exceed the maximum gross vehicle weight rating will exceed the limits of your vehicle and may result in damage to the engine, gearbox and structure, loss of vehicle control, vehicle rollover, and personal injury
- Modifications to the towing bracket by welding, drilling and cutting are not permitted. Changes can reduce the permissible maximum trailer weight
- Exceeding the maximum permissible vertical load on the towing bracket can lead to loss of control over the vehicle and personal injury

The following applies to towing devices installed by the converter:

- The maximum trailer weight must not exceed that of the unmodified vehicle
- All modifications to the vehicle must be described in the vehicle Owner's Manual or a separate description that shall be enclosed with the vehicle documentation
- The towing brackets must comply with the requirements of the local approval regulations
- Whenever holes are required in the vehicle frame, use welded spacers

See also [chapter 5.5 "Frame and body mounting"](#).

1.15.3 Towing capacities and specifications

Information

Refer to your vehicle operating manual for maximum trailer weight specifications.

2 Chassis

2.1 Running gear suspension

Warning note

- Do not alter, drill, cut or weld any suspension components, especially the steering rack, subframe or anti-roll bars, springs or shock absorbers, including mounting brackets
- The rear leaf springs are preloaded at the time of manufacture and should not be altered in any way in terms of spring rate or height during vehicle conversions. The addition or removal of leaves may result in spring failure or reduced function, as well as other vehicle-related problems for which Volkswagen Commercial Vehicles cannot be held responsible

Practical note

- Modifications to the suspension system may result in a deterioration of the driving characteristics and durability of the vehicle
- During welding work, the springs must be covered to protect them from welding spatter
- Do not touch the springs with welding electrodes or welding guns

Information

- For vehicles with Electronic Stability Control (ESC), do not change the wheelbase or extend the frame
- Do not damage the surface or corrosion protection of the spring during removal and assembly
- Do not add any additional axles

2.2 Brake system

2.2.1 General information

The brake system must be fully operational when the vehicle conversion is complete. Vehicle brake operating conditions must be checked, including the warning system and handbrakes.

Warning note

Air flow and cooling of the brake system must not be obstructed.

Information

- The brake fluid level must remain visible
- Free access to the brake fluid reservoir must be ensured for servicing work and adding brake fluid

2.2.2 Brake hoses

Warning note

Make sure that the mounting points for the brake hoses are removed or reattached with care. Damage to the brake hose mounting points or alignment may result in reduced clearance and cause wearing of major brake components. Renew any damaged parts before using the vehicle.

Practical note

Make sure the front and rear brake hoses are not twisted and are not near any body or chassis components.

No other additional lines are allowed to be fastened to brake hoses and brake lines.

Brake lines shall not be used to support or secure other components. The front and rear brake hoses must not rub, chafe, or rest against the body or chassis or body parts. Under all operating conditions, there must always be sufficient clearance and hose length to ensure that the brake hoses and brake lines are not subjected to an unauthorised load.

2.2.3 Overrun brake connection

Warning note

A pre-installed overrun brake cable provides a pulsed brake signal with different frequencies. This pulsed signal is not a direct current (DC) signal. If a retrofitted brake controller is installed, the vehicle owner or converter must ensure that it is compatible with all pulsed signals from the pre-installed overrun brake cable. Failure to ensure compatibility of your brake controller may result in loss of vehicle control, which could cause serious injury. If you have any questions about the specifications of the pulse signals, please contact your Volkswagen Commercial Vehicles partner or importer.

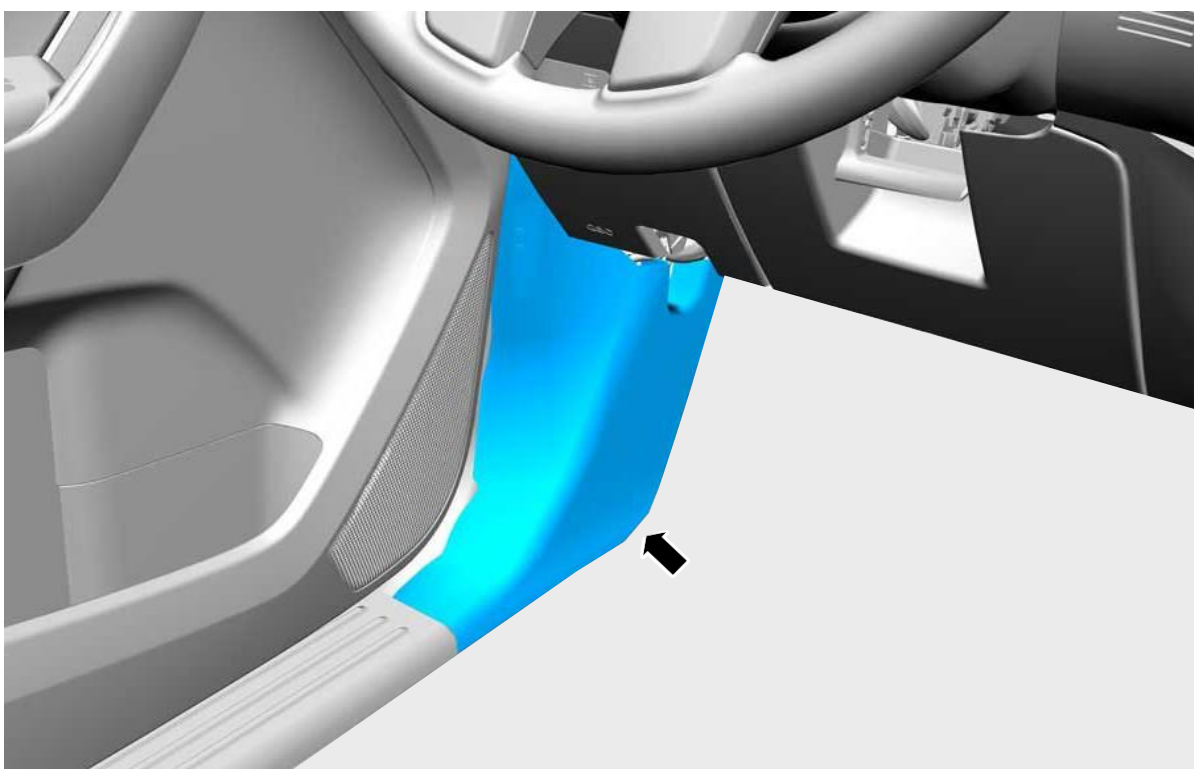

A pre-installed cable is located behind the footwell trim of the A-pillar and is marked TRAILER BRAKE CONTROLLER (control unit for overrun brake).

(Only available for certain markets, contact your importer)

- Wire colour blue/grey (BU/GY)

3 Drive train

3.1 Engine

3.1.1 Air flow areas of the engine cooling system

The cooling output of the engine must be maintained. The aim is to prevent accessories and attachments on the vehicle from restricting the air flow area.



Item	Description
A	Interference with cooling air flow in this area can result in impaired engine and gearbox cooling output.
B	Impairment of cooling air flow in this area poses a low risk of impaired drive train cooling output.
C	Impairment of cooling air flow in this area may result in impaired engine performance due to obstruction of the air flow for the charge air cooler.

3.1.2 Engine selection for conversions

The converter is responsible for selecting the engine with the correct emission values in accordance with the approval regulations valid in the registration states or the applicable local legislation, depending on the vehicle category and weight of the completed vehicle. The final weight of a vehicle after conversion determines whether a vehicle requires an engine for light or heavy duty commercial vehicles.

Please note the additional weight due to the vehicle conversion.

The weight is based on the reference mass, which is defined as the mass in running order, minus 75 kg for the driver, plus 100 kg uniform mass.

As a guideline, if the reference mass used for type approval of the completed vehicle

does not exceed 2,840 kg, a light commercial vehicle engine may be specified for N1 and N2 vehicles.

3.2 Fuel system

Warning note

- Make sure that the modified vehicle complies with all the approval regulations and legal requirements applicable in the market
- Do not remove the fuel cooler(if fitted) or relocate it when the vehicle is converted

Practical note

- Ensure that modifications to the vehicle do not obstruct air flow to the fuel cooler
- Ensure adequate clearance is maintained from all hot and moving components in all driving conditions
- Ensure that no sharp edges, including fasteners, are pointed at any component of the fuel system
- The fuel filler neck must be supported in accordance with the guidelines in this section
- Transport mode includes a calibration function for reducing the risk of corrosion of injectors
- Disabling transport mode before upgrading/refitting increases the risk of premature injector failure. For information on activating or deactivating transport mode, please contact your Volkswagen Commercial Vehicles partner or importer

3.2.1 Securing the fuel filler neck during transport

Practical note

The vehicle must not be operated while the fuel filler neck is in transport condition.

The fuel filler neck is secured to the frame bracket with a cable tie on vehicles with a chassis cab, but only for transporting the vehicle.

3.2.2 Securing the fuel filling system

Practical note

- Ensure that the mounting bracket for the filler neck is made of a conductive material and provides an earthing path for the fuel filler neck. It must be possible to compensate for different electrical voltage potentials
- If the vehicle body and support do not provide an earthing path for the fuel filler neck, a battery earth strap must be installed to connect the filler neck to the chassis frame
- The completed fuel filler pipe system must have a continuous slope of at least 2.1 degrees from the filler neck to the fuel tank and should have an entrance angle of at least 30 degrees
- When routing the fuel filler pipe, make sure it does not make contact with exhaust components or sharp edges
- The fuel filler pipe must not kink
- The midpoint of the filler neck must be at least 250 mm from the midpoint of the fuel tank and have an entrance angle of at least 30 degrees

Information

- Fasteners for securing the fuel filler pipe to the vehicle body are not supplied by VW Commercial Vehicles
- The routing of the filler and breather hose must not contain any dips. Additional support may be required to prevent the hose from sagging, which could create a dip. A dip in the line can cause the sudden escape of fuel from the filler neck when refuelling
- The modified installation of the fuel filling system must be such that it does not protrude beyond the exterior surface of the body or superstructure. A minimum distance to moving parts must be maintained. See the figure “Distance to vehicle body”
- If the vehicle is equipped with a capless filler neck and the capless system is not to be located in a filler shaft of the converted vehicle, it must be replaced with a threaded cap filler neck system because the capless filler neck must be protected from dust and dirt. Contact your Volkswagen Commercial Vehicles partner or importer to obtain a suitable component

Fuel filler neck – overview

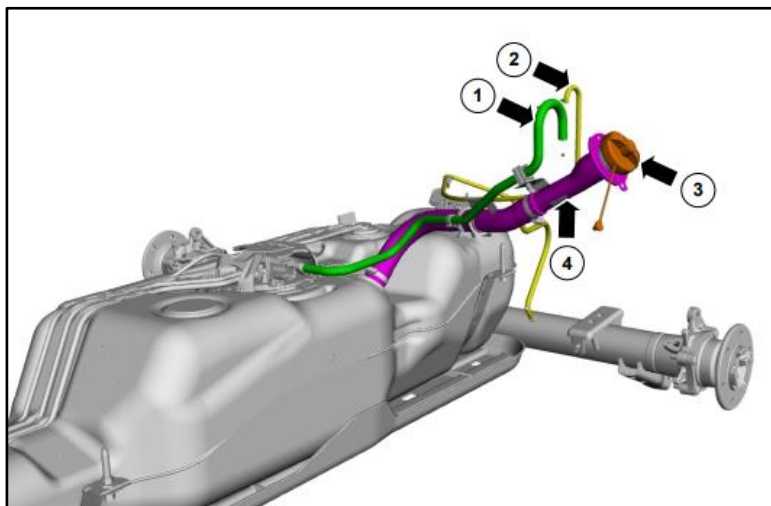

Item	Description
1	Tank vent hose
2	Breather pipe on the rear axle
3	Tank cap
4	Fuel filler pipe

Mounting bracket for fuel filler neck

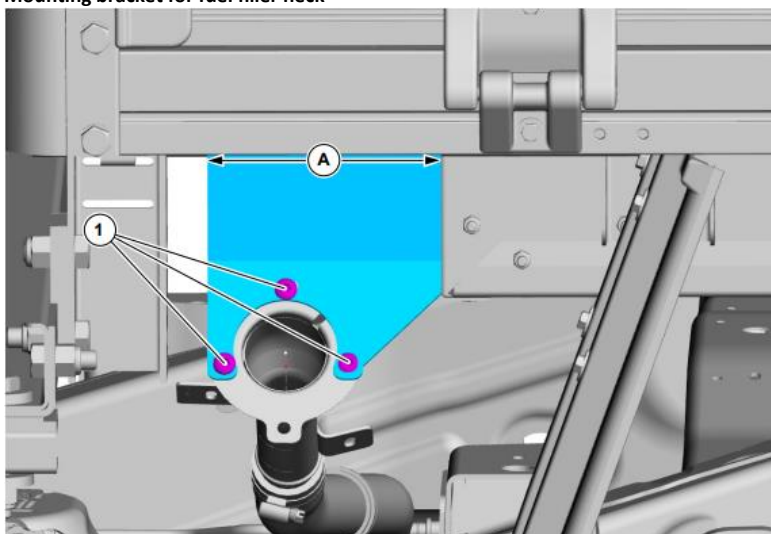

Item	Description
A	The width of the bracket must be at least 180 mm at the connection to the body
1	All three fastening points on the filler neck must be used

Fuel filler neck assembly

The fuel filler neck must be properly earthed to the body/chassis.

Volkswagen also provides the fuel filler neck for chassis with a cab as a Volkswagen replacement part that can be purchased from your Volkswagen Commercial Vehicles partner:

- Double cab – part number 2HJ.201.133

Angle of the filler neck

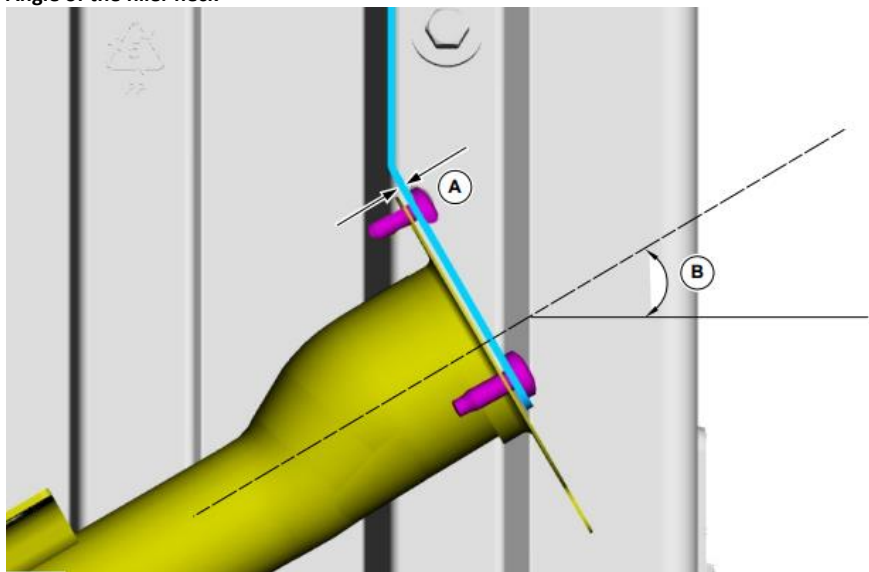

Installation dimensions – filler neck

Item	Description
A	The material thickness of the bracket must be at least 2 mm
B	An angle of 30° must be maintained to ensure good fuel flow and prevent backflow when refuelling.

Distance from vehicle body

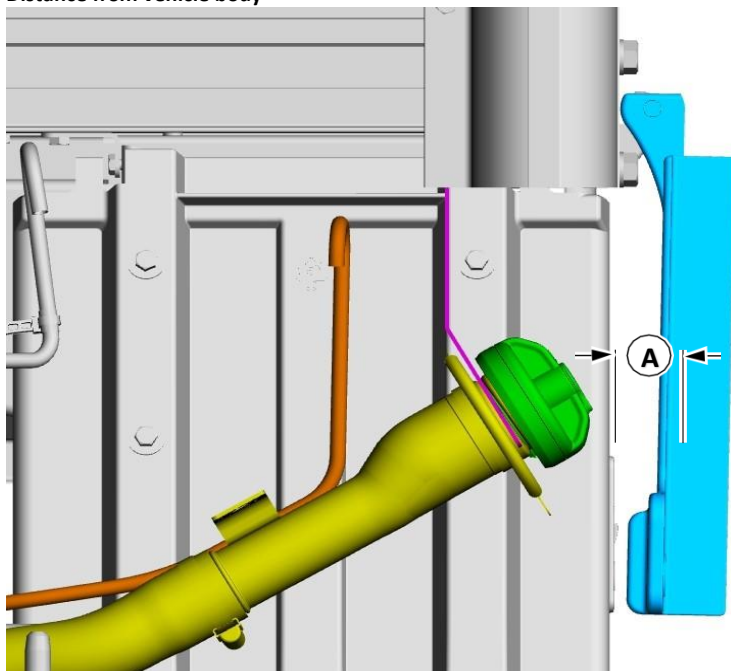

Item	Description
A	At least 9mm distance between the tank cap and the vehicle body, if necessary at the most unfavourable opening angle.

Height of fuel filler neck – chassis with chassis cab

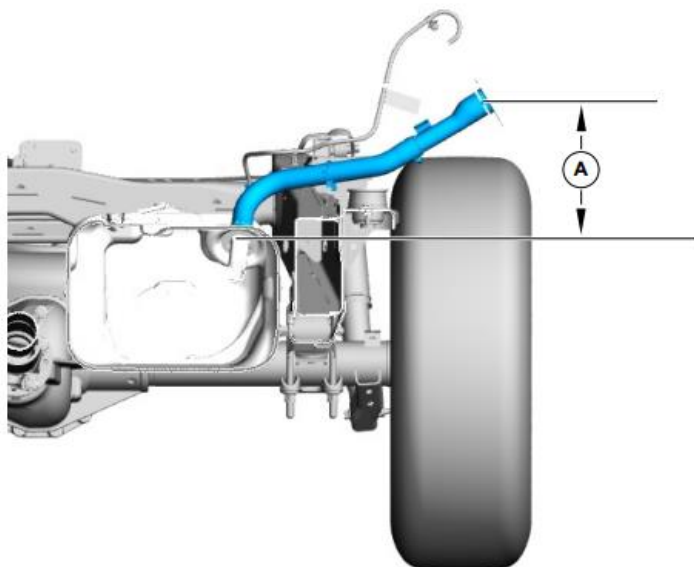

Item	Description
A	The filler neck opening height should be at least 250 mm, measured from the midpoint of the opening of the fuel tank to the midpoint of the filler neck opening.

3.2.3 Breather hose for fuel filling system (diesel)

The fuel tank breather hose must be routed so that there is a bend opening downwards at the end and the hose opening must be at least at the height described in this document to meet water permeability specifications and prevent water from entering the fuel system.

A section of the flexible fuel hose should be attached to the vehicle body with the open end at least 600 mm (4x2)* or 800 mm (4x4 or 4x2) above the ground. We recommend measuring this height when the vehicle is fully loaded.

The fuel tank breather hose must be routed so that it is protected and away from direct splash water, wheel splash, mud splash, and any water drainage holes that may be present.

The fuel tank breather hose must be routed upright with a downward bend at the end, as shown in the illustration. The downward bend must be located behind the filler neck as shown in the illustration.

A section of the flexible fuel hose should be attached to the vehicle body with the opening of the shepherd's crook at least 600 mm (4x2)* or 800 mm (4x4 or 4x2) above the ground. We recommend measuring this height when the vehicle is fully loaded.

*Only rear-wheel drive 110 kW EU4

Hose routing for the fuel tank breather system



Information

Contact your Volkswagen Commercial Vehicles dealership or importer to receive the correct part number for your vehicle.

Schematic diagram of mounting position for fuel tank breather hose

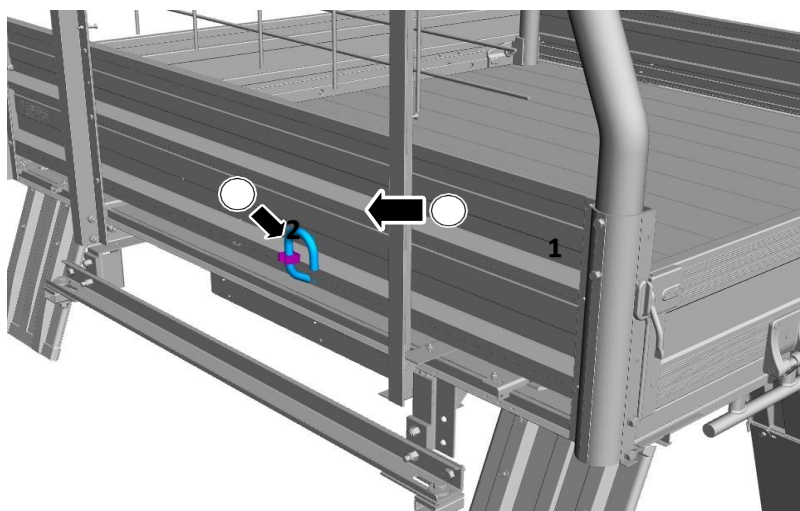

Item	Description
1	Front lower partition of a loading bed (loading bed rotated for clarity).
2	Fuel tank breather hose securely fastened.

3.2.4 Breather hose for axle venting

The breather hose for the rear differential should be fitted to the filler neck or the vehicle body. If required due to the assembly of additional add-ons, retrofits, or relocation of the fuel filler neck, the axle breather hose must be routed along the activated charcoal filter system. A section of the flexible fuel hose should be attached to the vehicle body with the open end at least 600 mm (4x2)* or 800 mm (4x4 or 4x2) above the ground. We recommend measuring this height when the vehicle is fully loaded. A breather cap can be used on the axle breather hose.

*Only rear-wheel drive 110 kW EU4

3.2.5 Fuel tanks with a big fuel range

Information

Fuel tanks with a big fuel range are not developed by Volkswagen and Volkswagen does not make any statements about the fit, workmanship, quality, safety or durability of these parts.

Although this modification improves functionality, the remaining range calculations may be somewhat different from standard parts and the corresponding calculations.

After the installation of a fuel tank with a big fuel range, the functionality of the remaining range is reduced.

To improve the system functionality, please use the VW ODIS diagnostic system as required:

- Connect the ODIS diagnostic system to the vehicle
- Read the parameters out of ODIS and display the corresponding menus
- In Configuration Parameters, select Fuel Tank Capacity (Tank Size A);
- Select the appropriate option after selecting the dialogue box:
 - Fuel Tank Capacity > Configuration Description
 - + Standard 80 l
 - + 120-litre fuel tank with big fuel range
 - + 140-litre fuel tank with big fuel range

3.3 System for “Selective Catalytic Reduction (SCR)”

3.3.1 Selective catalytic reduction system – diesel exhaust fluid (reducing agent)

Warning note

- The engine may not start if you tamper with or disable the selective catalytic reduction system
- Ensure that sufficient diesel exhaust fluid (reducing agent) is always added to ensure that the engine can be started
- The engine must not be started if the diesel exhaust fluid (reducing agent) is contaminated. Immediately replace the contaminated fluid
- The use and refilling of diesel exhaust fluid (reducing agent) is necessary for the vehicle to meet the legal emission requirements

The selective catalytic reduction system helps to reduce exhaust emissions by injecting diesel exhaust fluid (reducing agent) into the exhaust system.

For proper operation of this system, ensure that the diesel exhaust fluid (reducing agent) is topped up regularly.

Information

- When removing or renewing the cargo box, make sure that the angle of the filler hose and the distances between the fuel filler neck and the filler neck for diesel exhaust fluid (reducing agent) are maintained
- For more information on the diesel exhaust fluid system (reducing agent), refer to the Owner’s Manual for the vehicle

Filling the diesel exhaust fluid tank (reducing agent)

Warning note

Diesel exhaust fluid (AdBlue®) must not come into contact with eyes, skin or clothing. If the fluid comes into contact with the eyes, rinse them with plenty of water and seek medical attention. Clean affected skin with soap and water. If swallowed, drink plenty of water and seek medical attention immediately.

Practical note

Use only the vehicle-specific vented filler cap for diesel exhaust fluid (AdBlue®). Use of other diesel exhaust fluids (reducing agent-compatible) may damage the system.

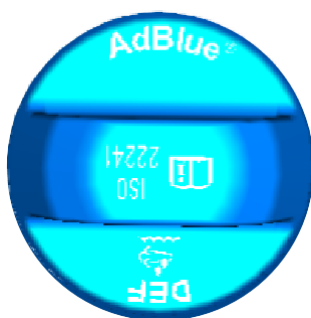

Information

Immediately wash off any spilled diesel exhaust fluid (AdBlue®) on a painted surface with mild soapy water.

2.0 I Turbo Diesel Euro 6d

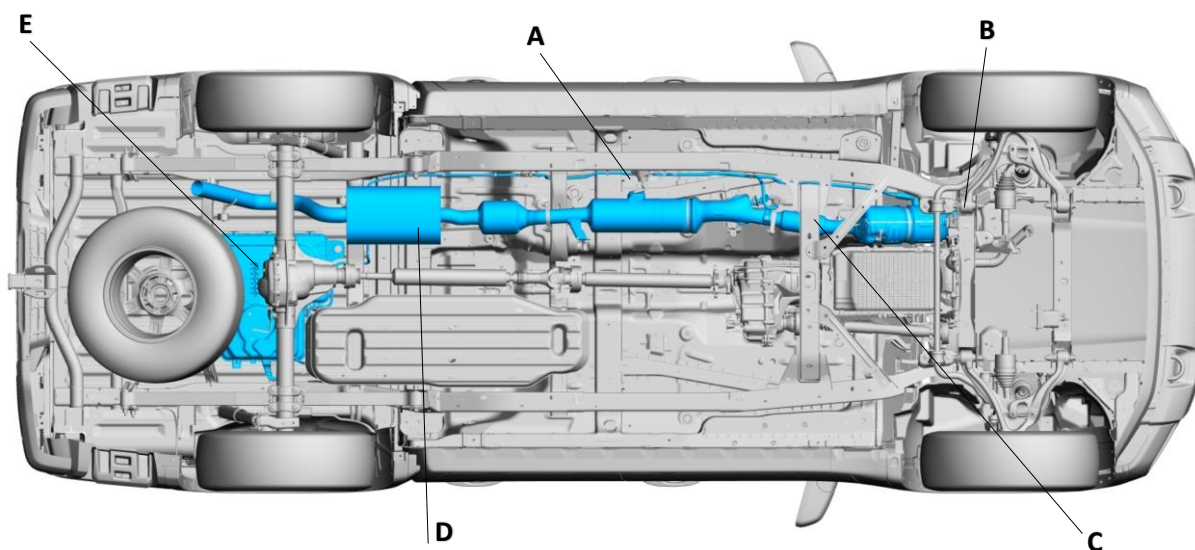

Item	Description
A	Pressure line for diesel exhaust fluid (reducing agent)
B	Injector for diesel exhaust fluid (reducing agent)
C	Injector for diesel exhaust fluid (reducing agent)
D	Exhaust system with selective catalytic reduction catalytic converter
E	Tank for diesel exhaust fluid (reducing agent)

3.0 | Turbo Diesel Euro 6d

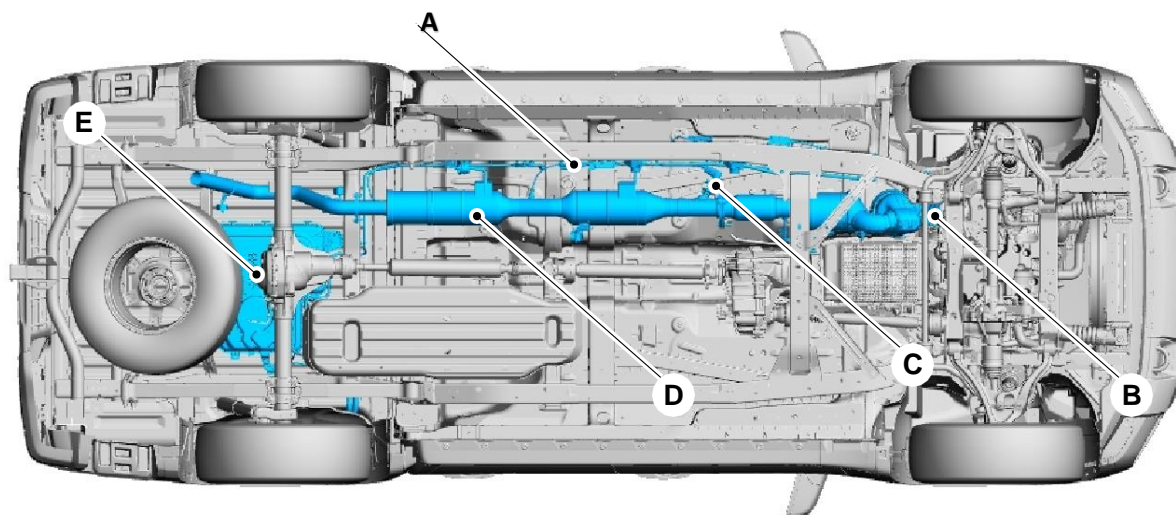

Item	Description
A	Pressure line for diesel exhaust fluid (reducing agent)
B	Injector for diesel exhaust fluid (reducing agent)
C	Injector for diesel exhaust fluid (reducing agent)
D	Exhaust system with selective catalytic reduction catalytic converter
E	Tank for diesel exhaust fluid (reducing agent)

Tank and filler neck for diesel exhaust fluid (reducing agent)

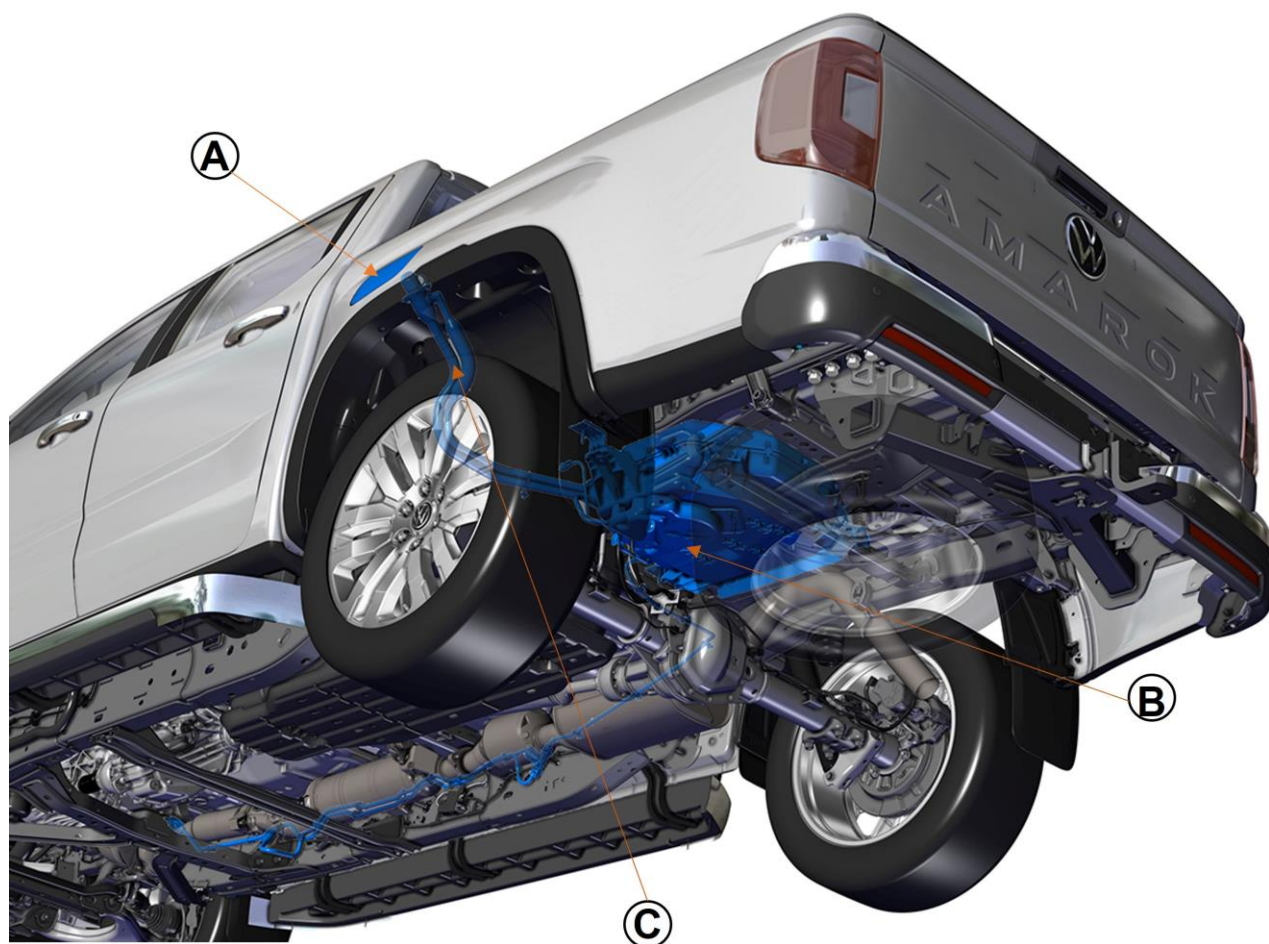

Item	Description
A	Filler neck for diesel exhaust fluid (reducing agent)
B	Tank for diesel exhaust fluid (reducing agent)
C	Filler hose for diesel exhaust fluid (reducing agent)

Fitting the filler neck for diesel exhaust fluid (reducing agent) – vehicles with chassis cab

Practical note

Make sure that the bracket for the filler neck is made of a conductive material and provides an earthing path for the filler neck.

Appropriate assembly tools and alignment of the diesel exhaust fluid filler neck and filler pipes are required if the vehicle modification will affect the diesel exhaust fluid (AdBlue®) system.

If the vehicle body and mounting bracket do not provide an earthing path for the filler neck, an earth strap must be added to connect the filler neck to the chassis frame.

Filler neck bracket for diesel exhaust fluid (reducing agent)

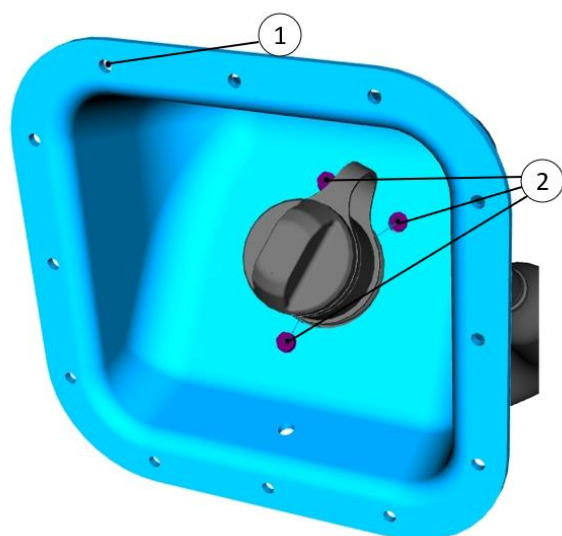

Item	Description
1	Mounting points for the diesel exhaust fluid filler neck bracket
2	All three mounting points on the diesel exhaust fluid (reducing agent) filler neck must be used and tightened to 5 Nm.

Angle of the diesel exhaust fluid (reducing agent) filler neck

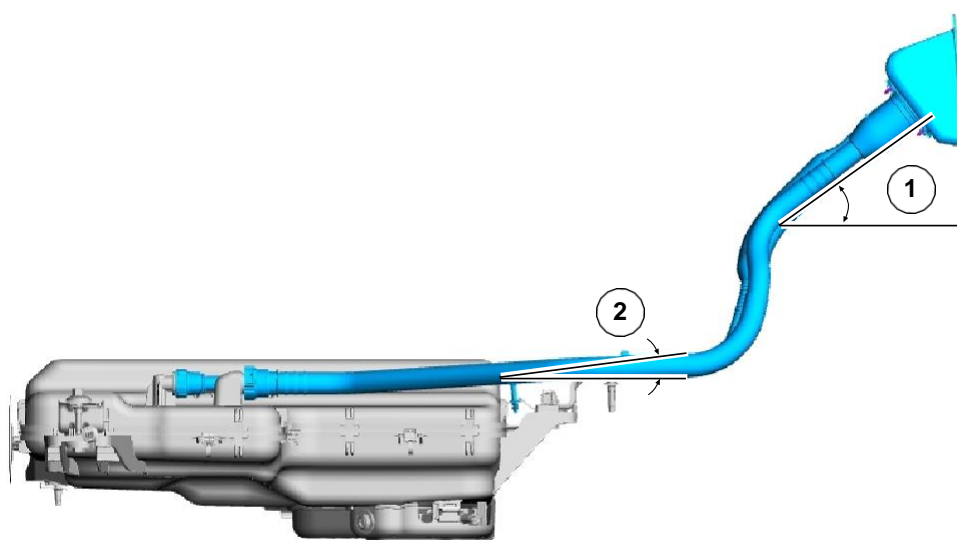

Item	Description
1	When refilling, an angle of 30° to the filler neck must be maintained to ensure a sufficient flow of the diesel exhaust fluid (reducing agent) and to prevent backflow.
2	The entire filler and breather hose from the filler neck to the tank must be at an angle of at least 2° (see illustration). This is necessary for ensuring proper filling process.

Practical note

Care must be taken when fitting U-bolts or other fasteners on the frame rail, as the diesel exhaust fluid (reducing agent) line can be pinched and crushed. To avoid damaging/crushing of this line, converters/installers should inspect the underside of the frame carriers and check the routing of the line before fitting any parts. Make sure the line does not have an adverse effect on the clamping surface. If additional clearance is needed for the diesel exhaust fluid (reducing agent) line, the line can be moved within the existing positioning clips by rotating the line back and forth while gently pulling on the line. This will create the necessary clearance for inserting the U-bolt between the frame rail and the diesel exhaust fluid (reducing agent) line.

Information

- The finished installation of the supply line for the diesel exhaust fluid (reducing agent) must have a continuous downward gradient of at least 2° from the filler neck to the tank
- The filling hoses for the diesel exhaust fluid (reducing agent) must be routed in such a way that they cannot come into contact with exhaust components or sharp edges
- The routing of the diesel exhaust fluid filling hose (reducing agent) and the breather hose must not contain any dips. Additional support may be required to prevent the diesel exhaust fluid (reducing agent) filling hose from sagging, which could cause backing-up in a dip. A dip in the line can cause splashing or backflow during normal filling operations and can also cause the collected diesel exhaust fluid (reducing agent) to freeze in the line and damage the component.
- The filling hose for the diesel exhaust fluid (reducing agent) must not kink
- Do not extend the diesel exhaust fluid filler hose so that it protrudes beyond the vehicle body
- If the diesel exhaust fluid (reducing agent) filler housing supplied with the kit is not used, the converter must ensure that the filler neck is at an angle of at least 30° to the horizontal
- If the diesel exhaust fluid (reducing agent) filler housing supplied with the kit is used, the three fasteners included in the kit must be used to secure the container to the housing
- There must be a distance of at least 9 mm between the filler cap and the vehicle body. See also [chapter 3.2.2 “Vehicle body, Securing the fuel filling system”](#), Figure: Distance to the vehicle body.

A kit approved by Volkswagen Commercial Vehicles for routing the diesel exhaust fluid (reducing agent) filler neck is available. Contact your local Volkswagen Commercial Vehicles partner or importer.

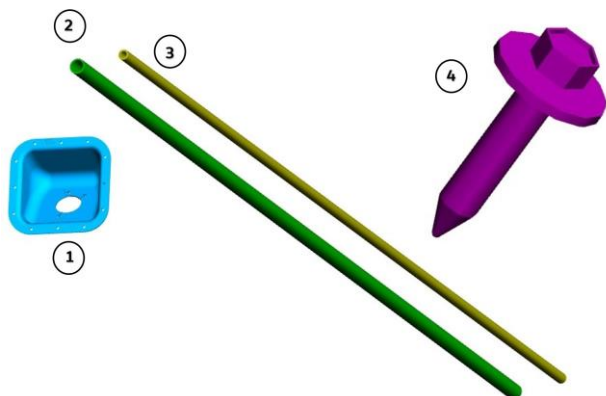
Diesel emission fluid filler neck routing kit

The kit for routing the diesel exhaust fluid (reducing agent) filler neck includes:

Item	Description
1	Filler housing
2	Main filler pipe (large diameter EPDM pipe)
3	Breather pipe (smaller diameter EPDM pipe)
4	Screws for fastening the filler neck to the housing

If necessary, the hoses and pipes of the diesel emission control kit can be shortened to the desired length.

Use cable ties or similar fasteners to keep the hoses and pipes within the desired routing path while the vehicle is in operation.

Information

The kit does not contain any cable ties or hose clips.

4 Electrics

4.1 Installation and routing guidelines for electrical wiring

4.1.1 Wiring splicing method



Volkswagen Commercial Vehicles strongly discourages the use of cable splices because the resulting connection does not have a reliable quality of workmanship. However, if a cable splice is unavoidable, it must be made with heat-shrinking DuraSeal to be environmentally sealed and with a suitable nylon insulated crimp splice. To further improve the connection, the splice should also be sealed with a suitable heat-shrink hose. For further information, please contact your Volkswagen Commercial Vehicles partner or importer.

4.1.2 Cable guide through cab panel

There are two points where you can route additional cables through the front plenum chamber bulkhead into the vehicle interior.

Feed-through points for the wiring



- 1 Dash panel feed-through, left side
- 2 Dash panel feed-through, right side

Additional grommet passage

Grommets are a component of the main wiring harness, which contains securely tied bundles of cables. It is not possible to route additional cables with the cable bundle through the grommets. The grommets have a separate passage that is moulded into the grommet and sealed. If it is necessary to feed additional cables through the grommets, the separate passageway must be opened

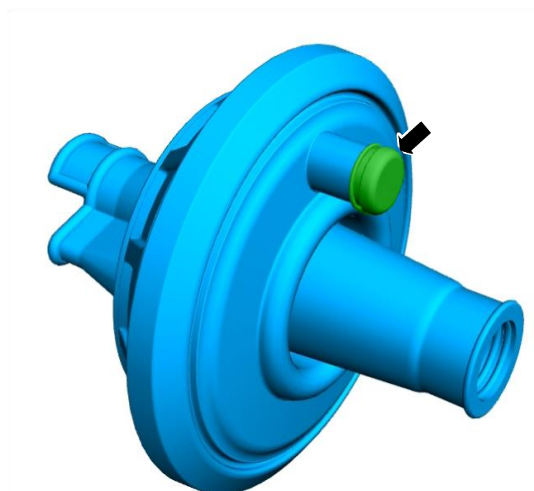

The following information must thereby be observed:

- Make sure that the immediate vicinity is clear of obstructions and/or components, in order to avoid damaging critical systems
- Use a suitable tool, such as a knife or diagonal cutter
- Cut or shorten the outer end of the passage accordingly
- Feed the electrical wiring through the grommet as required
- Apply sealant as needed to ensure water-tightness

Information

- The maximum diameter of the additional wire bundle is 8 mm
- There are two locations in the dash panel that are intended for routing cables (see figure above)

Practical note

- Electrical wiring harnesses that pass through sheet metal must be fed through protective grommets, which also ensure a watertight seal. A windscreen sealant or silicone sealant should be used. Adhesive and tape are not acceptable
- The grommet feed-through must be adequately sealed to prevent corrosion and water ingress

4.2 Battery and cables

4.2.1 Battery information

If a battery has been disconnected from the vehicle electrical system, all important basic settings of the vehicle are retained.

The vehicle retains its “normal” power management setting and remembers exactly what its previous configuration was. All radio settings are retained. However, the clock and the window controller must be reset. For more information, refer to the Owner’s Manual for the vehicle.

Battery voltage requirements and testing

All voltage measurements must be performed with an accuracy of +/- 5% to the published values.

To maximise battery life, all batteries must have a minimum open-circuit voltage of not less than 12.75 V at the time of arrival at the converter.

When the battery is installed and connected to the vehicle’s electrical system with no load, the open-circuit voltage must not be less than 12.65 V. When the vehicle is delivered to the customer, the open-circuit voltage must not be less than 12.50 V.

Discharging surface charges

Before performing manual voltage tests, ensure the battery voltage is stable and free of surface charges that may be present due to certain engine running conditions. Voltage measurements can be distorted by surface charges. To ensure that surface charges are not present, we recommend the following measures:

1. Turn on the headlights for five seconds or the parking lights for 15 seconds
2. Turn off all electrical equipment (including lamps, blowers, heaters etc.)
3. Wait 10 minutes before measuring the voltage

Stock vehicles

For vehicles that are parked at the converter and not used for more than four days, the battery’s earth wire should be disconnected. Before transporting to the customer, the battery’s earth wire must be reconnected and the voltage rechecked. The voltage should not be less than 12.50 V.

Sequence of the battery charging process

Warning note

- Always follow the instructions from the manufacturer of the battery charger
- Do not start the vehicle with a battery from another vehicle (jump start)
- Ensure that the electrolyte level is accurate. If the filling level is too high, the electrolyte may leak out, causing damage to the vehicle and possibly personal injury

Practical note

- Do not charge a discharged battery with the alternator. It would take more than eight hours of continuous driving without any additional electrical equipment being switched on
- Make sure the battery electrolyte reaches the upper fill level marking
- Connect the battery charger cables to the battery before switching on the charger
- Turn off the battery charger before disconnecting the battery charger cables from the battery

Information

- Batteries generally do not require maintenance, but under certain conditions it is possible for the electrolyte in a battery to fall below the minimum level
- We recommend using the Midtronics GR-590 Battery Management Centre, which was specifically designed for use with silver-calcium batteries
- Once connected to the battery, the battery charger detects the battery's state of charge and then applies the appropriate charge rate and charge duration. When the battery is fully charged, the battery charger switches to standby mode and maintains the battery in a fully charged state, preventing excessive gassing and overcharging
- The Midtronics DCA-8000 Battery Management Centre also includes a software program that can assist in the recovery of deeply discharged (sulphated) batteries.
- There are various charging methods and a variety of battery chargers. Regardless of which method is used, it must be done carefully to avoid battery damage and possible personal injury
- Specific instructions are included with each battery charger and must be followed carefully. The user must always observe the safety precautions provided by the device manufacturer
- A battery that has been stored in a heavily discharged state may initially only receive the charging current slowly. In these cases, the initial charging current may be so low that the ammeter on some battery testers will not indicate a charge for five to 10 minutes
- Batteries should be recharged before they are put into storage. Batteries should not be left in a discharged state as this will result in the formation of sulphate crystals that cannot be broken down by conventional charging. This will have a significant adverse effect on

battery performance. Batteries should be connected to trickle chargers during storage. Conventional battery chargers should not be rated below 10% of the Ah nominal power to prevent excessive gassing.

Intelligent multi-stage battery chargers can also be used for better performance

- Automatic battery chargers are also protected against reverse polarity and require no adjustment or monitoring
- Slow charging gradually restores the battery to a full state of charge. As the charging current is relatively low, the possibility of overcharging the battery is minimised. The charging current used should be approximately 5% of the reserve capacity of the battery being charged (approximately three to six amps depending on battery size). The charging current should be adjusted 10 minutes after starting the first setting and again after one hour. The battery is then charged for between 8 and 12 hours
- When charging with a constant charging voltage, the battery is charged with the set maximum charging voltage. The voltage used depends on the condition of the battery charger and the age and temperature of the battery. This type of battery charger initially charges the battery at a high initial charging current and decreases as the battery voltage increases. When using a constant voltage battery charger, the charging current should be measured after five minutes. The battery charger is switched off when the charging current drops to one third of the measured value or after eight hours, whichever occurs first
- Multiple battery chargers are designed to recharge more than one battery at the same time. Of the two different types of multiple battery chargers available, only those that recharge batteries in series should be used, and it is important that batteries have the same or very similar ratings and voltages. Charging in parallel is not recommended
- We do not recommend using a fast (boost) battery charger as it can damage a battery.
Fast charging is suitable for enabling the power unit to start again. Fast charging does not put a battery into a full state of charge and therefore must be followed by a period of slow charging. Excessively fast charging can damage a battery. For this reason, charging times must be carefully controlled. The charging functions of fast battery chargers vary widely, so it is very important to strictly follow the equipment manufacturer's instructions. A 30-A charge for up to 30 minutes is the most common fast charge

application. If the battery is severely discharged and requires additional treatment, an additional charge of 20 A for a period of up to one and a half hours should be applied. Fast charging for a period longer than two hours greatly increases the risk of damaging the rechargeable battery

- Before disconnecting the battery, note the radio keycode and the stored radio stations
- When connecting and disconnecting the battery from the vehicle, make sure the battery-earth wire is disconnected first and connected last, and that all electrical equipment is turned off. Only then disconnect the battery earth wire
 1. Disconnect the battery earth wire
 2. Remove the battery from the vehicle
 3. Check that the electrolyte in the battery reaches the maximum level indicated. Top up with distilled/de-ionised water if necessary
 4. Connect the positive red terminal from the battery charger to the positive battery terminal. Connect the negative black terminal from the battery charger to the negative battery terminal
 5. Connect the negative black terminal from the battery charger to the negative battery terminal
 6. Follow the instructions provided with the battery charger to charge the battery
 7. To disconnect the battery charger, reverse the connection procedure

Information

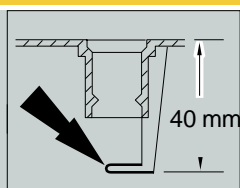
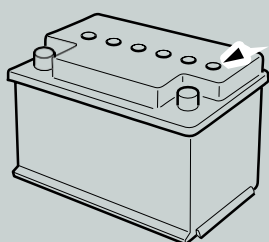

The maximum electrolyte level is approximately 40 mm below the top of the battery housing. This corresponds to a point just below the bottom edge of the battery housing.

Tightening torque of the battery cable

The correct tightening torque for battery clamps can be found in the Workshop Manual. Please contact your Volkswagen Commercial Vehicles partner or importer.

Battery specifications

Warning note

- For vehicles equipped with **non**-maintenance-free batteries, regular controls must be carried out to determine whether the electrolyte level is correct
- When charging the battery in the vehicle, make sure the battery charger is firmly connected to the vehicle earth and not to the negative battery terminal. This ensures that the BMS (Battery Management System) detects the battery charge

Practical note

When externally charging batteries, ensure that the maximum voltage of 14.6 V is not exceeded.

Battery part numbers and usage

If a vehicle's battery type is changed to other compatible derivatives, the Volkswagen Commercial Vehicles dealership must reconfigure the vehicle to the new battery types.

The central vehicle configuration can be updated by a Volkswagen Commercial Vehicles partner or importer.

Type	Service description	Size
Standard battery	75 Ah, 750CCA	H7
Auto start stop battery	80 Ah, 800CCA, AGM Deep Cycle technology	H7
Auto start stop battery	92 Ah, 850CCA, AGM Deep Cycle technology	H8

If the battery type of a vehicle is replaced by compatible components, the vehicle must then be configured for the new battery types. The central module configuration can be updated by a Volkswagen Commercial Vehicles partner.

Battery management system (BMS)

Practical note

Loads with high currents must be earthed at the earth point of the vehicle/chassis and not at the earth point of the battery management sensor (BMS).

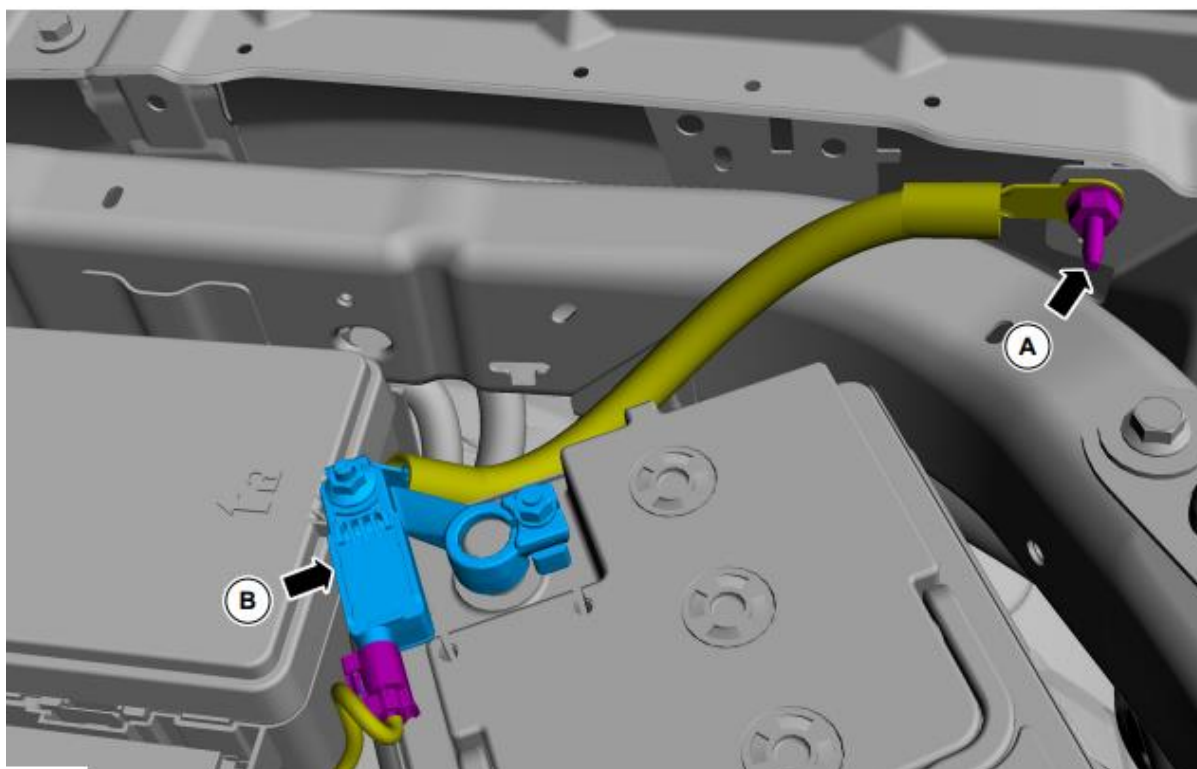

Item	Description
A	Vehicle/body earth
B	Battery management sensor

To manually disconnect the battery, disconnect the earth cable from the earth point (A) of the vehicle/body and place the disconnect switch between this terminal and the existing earth point. Use a cable with a suitable cross section and a sufficient switch rating (at least 300 A) and keep the length of the additional cable to a minimum.

Information

- The battery management sensor (BMS) is connected to the vehicle's BCM and also switches off if the battery is isolated and the BCM is not receiving power. At this point, the vehicle is completely electrically disconnected from the battery
- Installing an additional battery with a voltage dependent control unit can prevent all batteries (main and additional battery) from reaching a full state of charge. This is due to the Smart Regenerative Charging (SRC) function, whose purpose is to reduce fuel consumption
- No electrical equipment should be connected directly to the battery negative terminal, as this would bypass the battery management sensor and produce false charge level displays.
- The Amarok is equipped with the Battery Management Sensor (BMS) function. This system measures battery charge to efficiently charge the battery while simultaneously reducing fuel consumption and emissions
- It is important to ensure that all additional electrical equipment or accessories are properly earthed to the vehicle body so that the system can detect the additional load. If a connection is made to the negative battery terminal, the battery management sensor will not detect the load or charging. This may result in the battery being undercharged and consequently unable to restart the vehicle.

Additional battery on vehicles with a battery management sensor (BMS)**Information**

- At high loads, a battery isolator switch should be used to interrupt the connection to the primary battery at 12.7 V (75% state of charge) to ensure that the vehicle's starting capability is maintained. Examples of high load connections include winches / trailer accessories / refrigerators etc.
- Additional loads must always be connected to the vehicle earth and not to the negative battery terminal
- Ensure that the additional battery connection is securely fastened with suitable brackets to prevent vibration damage or contact with surrounding components
- For vehicles equipped with a battery management sensor, an additional battery can be connected using an on-board battery charger (DC/DC converter), which is connected via an additional terminal to the B+ terminal of the starter with a fused and grounded 30 A connection
- The maximum thickness of the additional terminal installed over the terminal of the starter cable terminal must not exceed 2.0 mm
- If present, ensure that the existing nut is reused

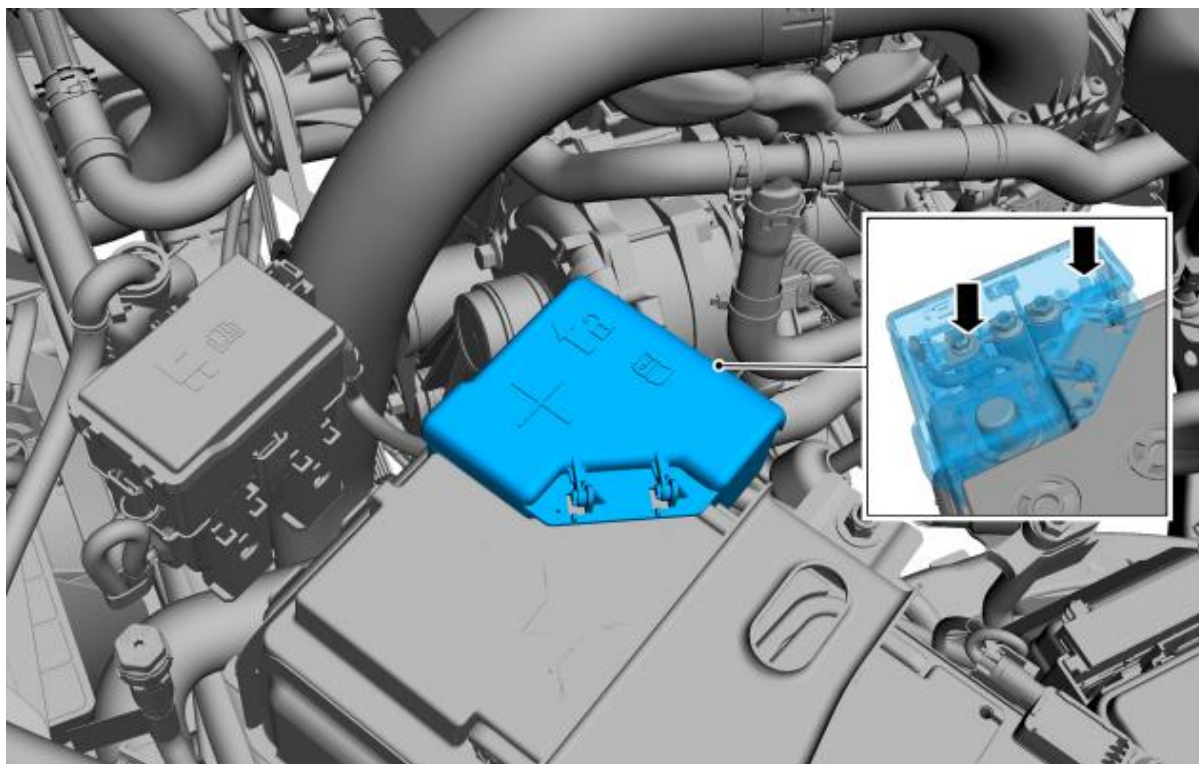
B+ terminal for charging additional batteries

Item	Description
M5 Stud	Auxiliary B+ supply with low to medium current.
M6 Stud	Auxiliary B+ supply with heavy current.

There is one empty position available on the positive battery fuse block. This free position can be used to connect the additional battery system and for all aftermarket installations that require a 12-V battery supply.

Battery connections should be properly tightened. Contact your authorised Volkswagen Commercial Vehicles partner or importer for the correct torque specifications.

Information

Ensure that the fused connection is secured with appropriate devices to reduce vibration damage or contact with surrounding components.

Engine compartment earth points

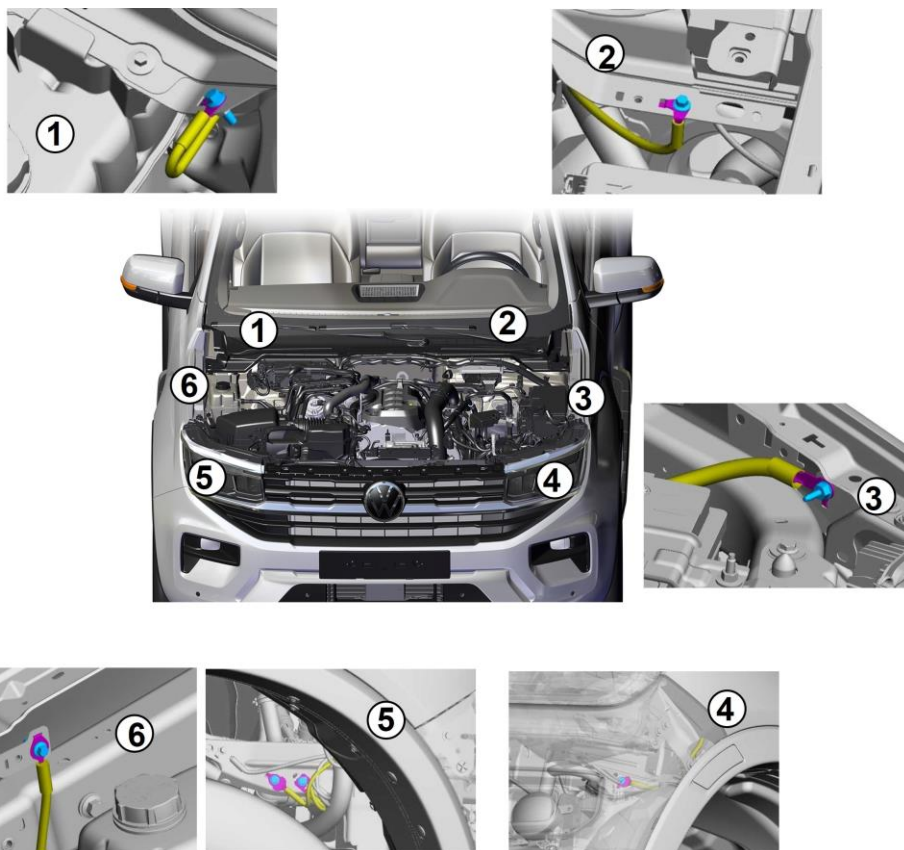

Item	Description
1	Earth point-on the body in the area under the bonnet on the right
2	Earth point on the body in the area under the bonnet on the left
3	Earth point on the left-hand side of the wing inner panel
4	Earth point on panel below the vehicle battery
5	Earth point on panel under air filter assembly (behind wing liner)
6	Earth point on the right-hand side of the wing inner panel

Earth point connections must be properly tightened.

Contact your authorised Volkswagen Commercial Vehicles partner or importer for the correct torque specifications.

Earth points – frame rear right

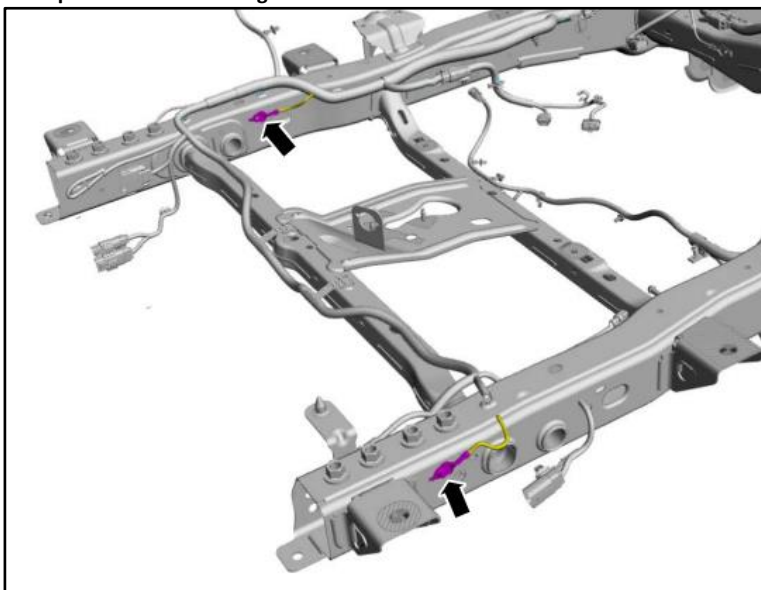

Earth points – frame rear left

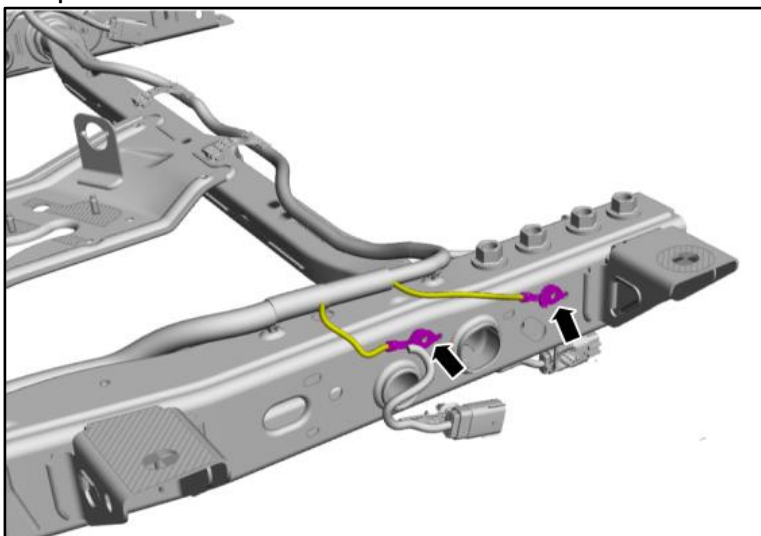

Earth points – frame front

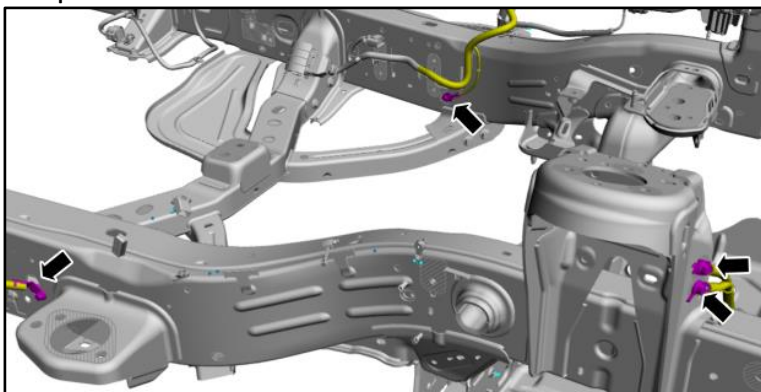

Earth points – frame front left

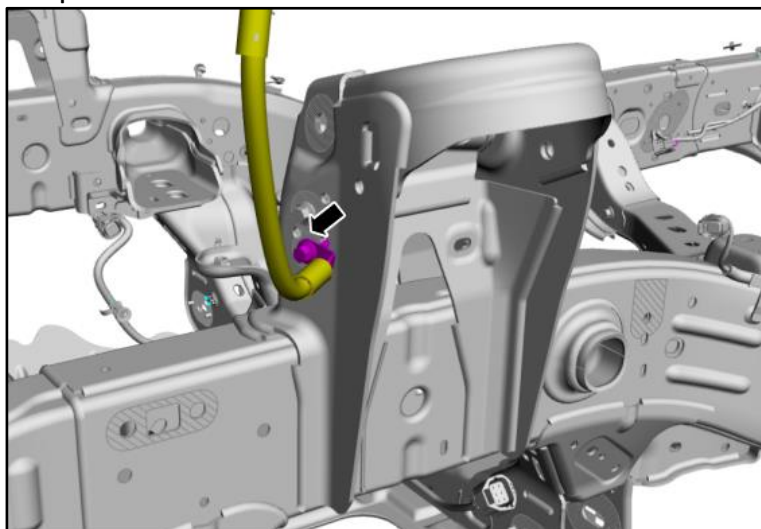

Earth points – frame front left

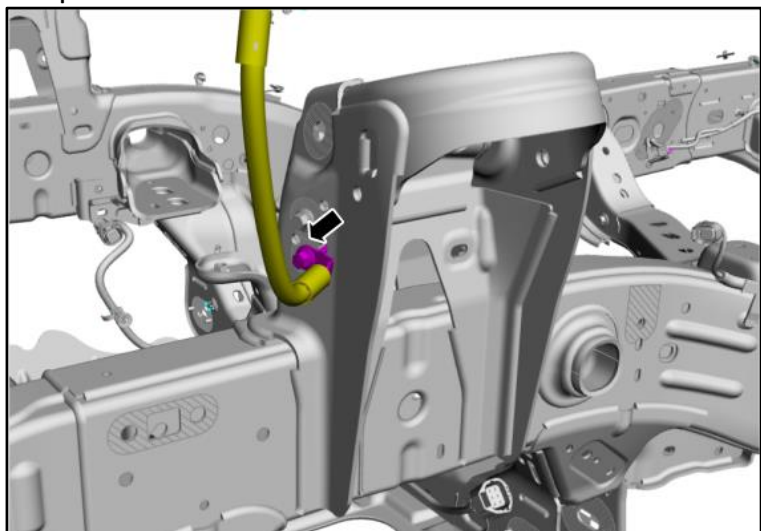

Earth points – inner frame front right

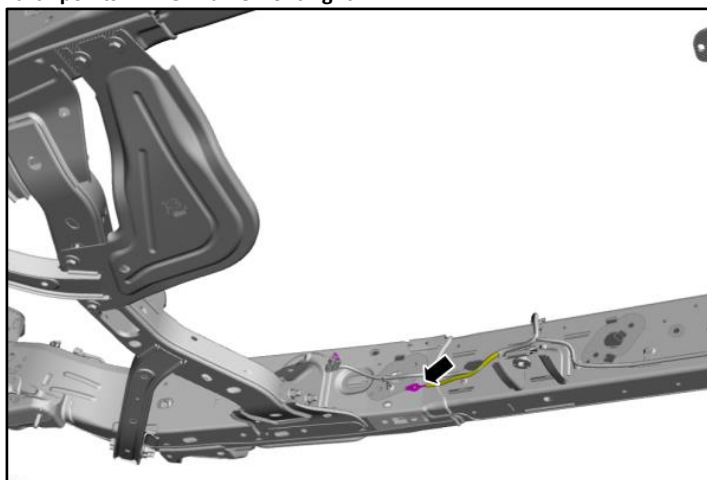

4.2.2 Connection of additional loads/accessories – for vehicles with factory-installed additional switches, wiring and fuse boxes

Warning note

- Make sure that all electrical connections and wiring comply with local regulatory standards
- Under no circumstances should non-fused electrical connections be made directly to any of the vehicle's battery terminals

Information

- Auxiliary earth points must always be connected to the nominated earth points and not to the negative battery terminal
- Refer to the vehicle operating manual for an overview of auxiliary switches
- Vehicles equipped with a diesel engine should only use the additional switches when the engine is running. The diesel engine's glow plug can cause a reduction in battery power if the ignition key is in the ON position. Using the additional switches, even for a short period of time, may drain your battery and prevent the engine from starting
- Vehicles may be equipped with factory-installed additional switches, fuses, and wiring that make it possible to install electrical accessories that operate with fuse-protected relays. The additional switches, fuses, and wiring include:
 - + Additional switch panel
 - + Additional fuse box with integrated relay
 - + Additional cabling connections
- The additional switches will only operate when the ignition is in the ON position, or in the OFF position if the accessory delay is active, regardless of whether the engine is running or not

Location/position of the fuse box and the wiring

Positions of additional switches, fuse box and wiring:

2 = additional fuse box located near left headlight

3 = near the electrical-connector for the towing bracket

4 = located near the additional fuse box

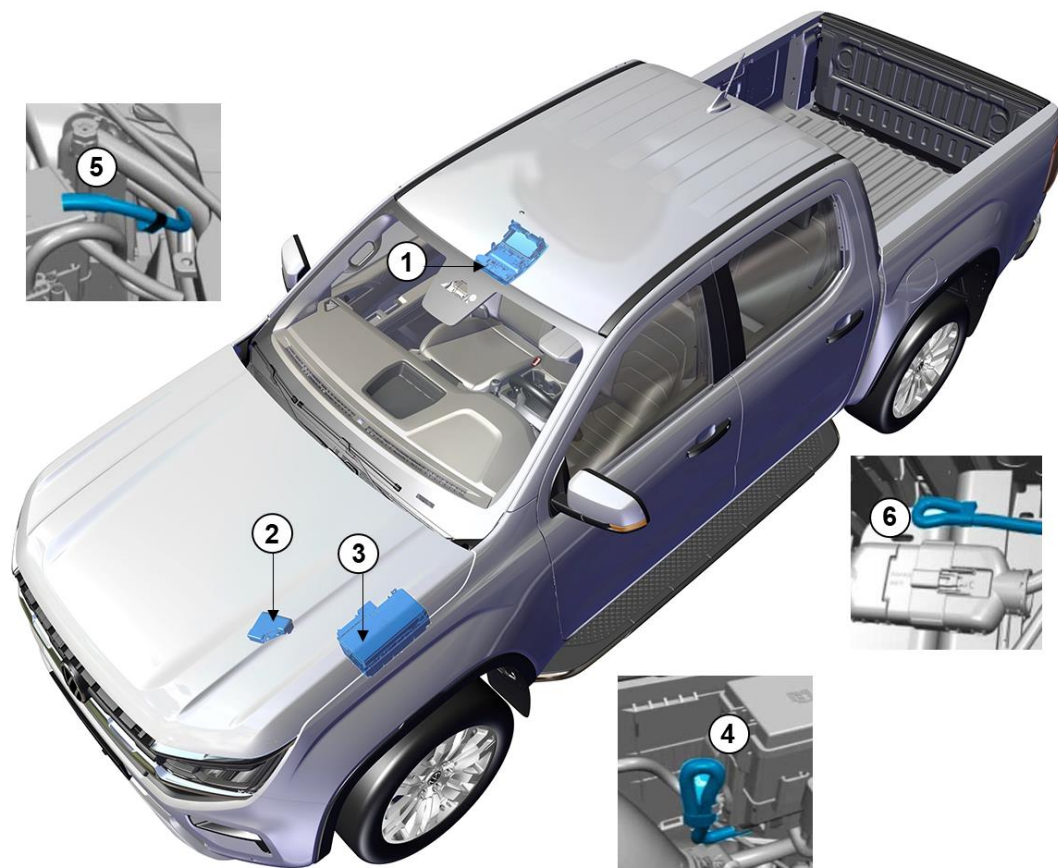

Location/position of the fuse boxes and the wiring

Position	Description	Position in the vehicle
1	Additional switch panel	(see illustration above)
2	Additional fuse box (with relay)	(see illustration above)
3	Engine compartment fuse box	(see illustration above)
4	Wiring circuit	near the additional fuse box
5	Wiring circuit	near the radiator mounting plate
6	Wiring for wiring circuit	near the electrical connection point for the towing bracket

Information

Circuits from the additional fuse box are powered during the run/start condition. All other wiring is disconnected at both ends.

Identifying the connections for the additional fuse box

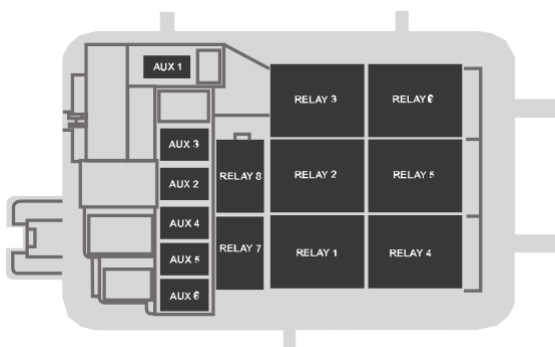

Overhead console additional switches	Cable colour	Cable size	Fuse	Protected component	Position	Note
AUX 1	Purple/green	1.5 mm ²	5 A	Relay 1	B	-
AUX 2	Blue/green	1.5 mm ²	15 A	Relay 2	B	-
AUX 3	Yellow/orange	1.5 mm ²	15 A	Relay 3	C	-
AUX 4	Brown	1.5 mm ²	15 A	Relay 4	C	-
AUX 5	Green/brown	2.5 mm ²	25 A	Relay 5 – driving lights	B	-
AUX 6	Yellow	2.5 mm ²	25 A	Relay 6 – driving lights	A	-
-	-	-	-	Relay 7	-	This relay only operates when the main beam headlights are switched on as per German federal requirements.
-	-	-	-	Relay 8	-	Additional power supply switch
AUX 3 – earth	Black/grey	1.5 mm ²	-	-	C	-
AUX 4 – earth	Black/green	1.5 mm ²	-	-	C	-
AUX 6 – earth	Black/yellow	2.5 mm ²	-	-	A	-

4.2.3 Alternator

Power output of the alternators

Contact your local Volkswagen Commercial Vehicles dealership or importer for alternator output current specifications for your vehicle's alternator.

Drive train	Current output	Amps at 80.6°F (27°C)	Belt pulley ratio	Belt pulley type	Type of voltage regulator
2.0 l Diesel Single Turbo*	155	100 A at 750 rpm to 155 A at 2,500 rpm (max.)	2.8	Freewheel clutch – alternator (OAD)	Internal electronics
2.0 l Diesel Single Turbo* / 2.0 l Diesel Bi-Turbo	250	155 A at 750 rpm to 250 A at 2,300 rpm (max.)			
3.0 l diesel engine	250	145 A at 750 rpm to 250 A at 2,500 rpm (max.)	2.66		

RPM speeds (**rpm**) in the table are engine speeds, not alternator speeds.

(*) Depends on the market

Power curve of the alternator output – 155 A current output

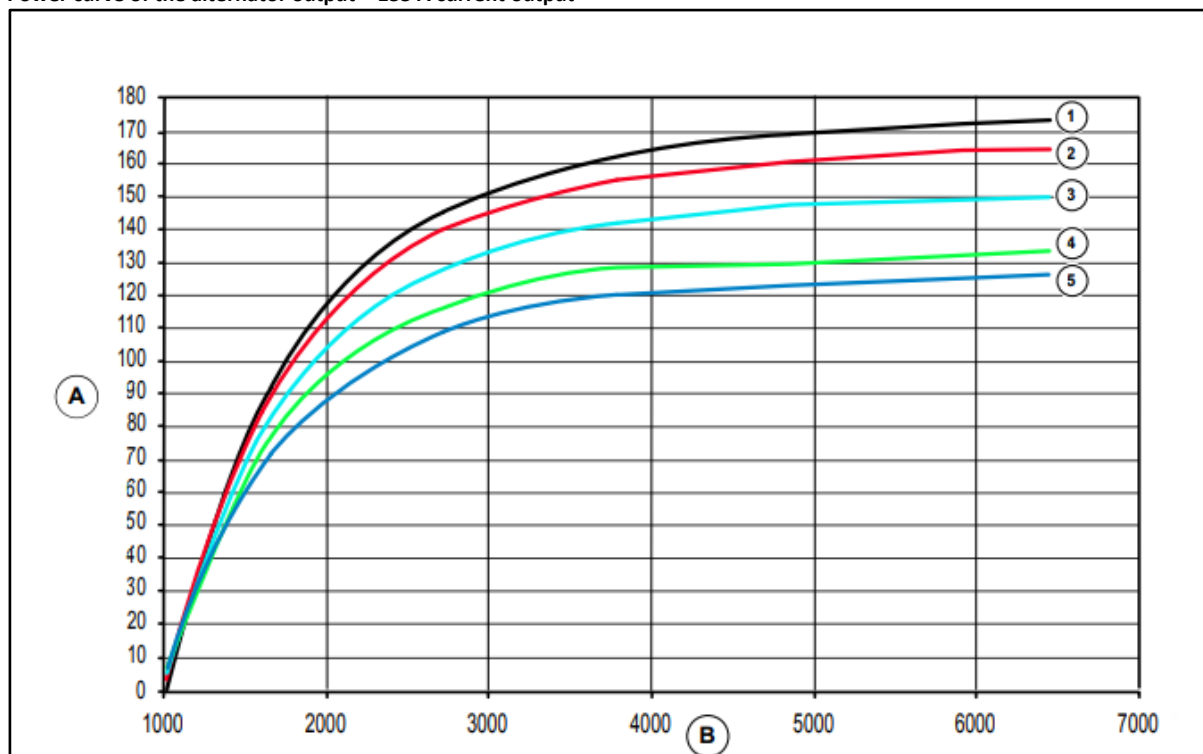

Item	Description
A	Output current (amps)
B	Alternator speed (rpm)
1	Temperature 0°C (30°F)
2	Temperature 27°C (80°F)
3	Temperature 60°C (140°F)
4	Temperature 93°C (200°F)
5	Temperature 115°C (240°F)

Power curve of the alternator output – 250 A current output

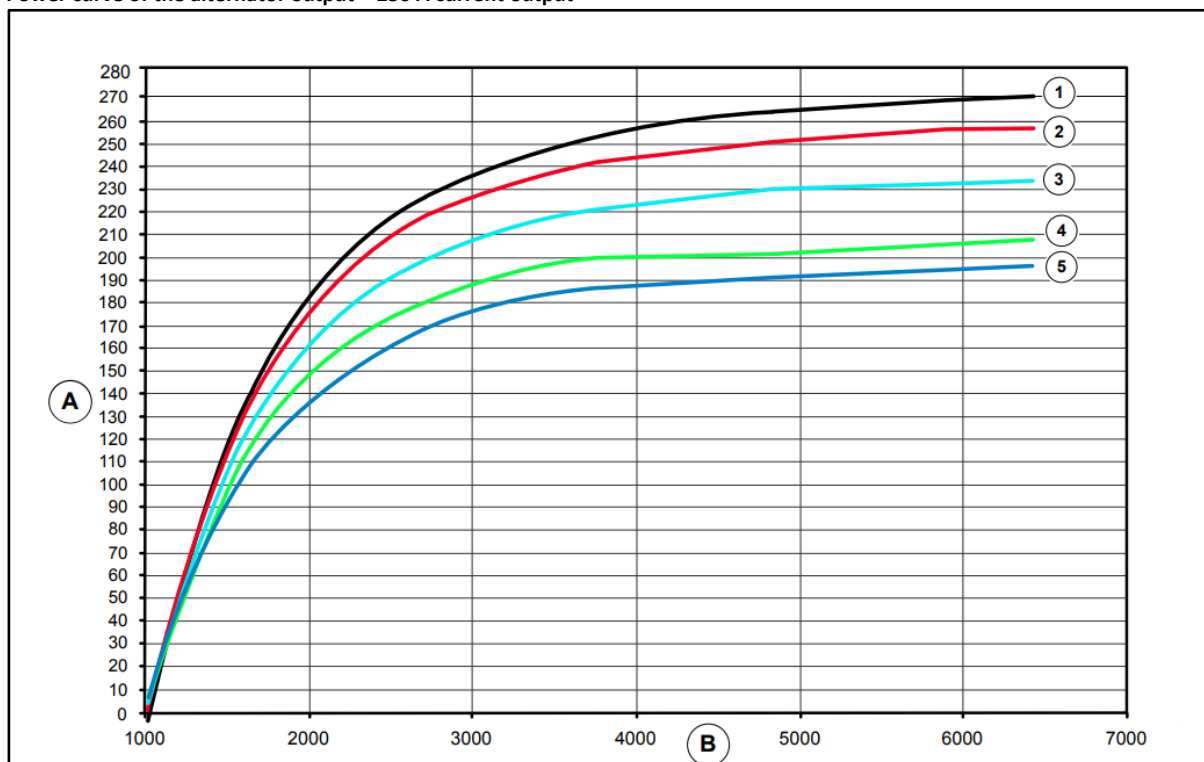

Item	Description
A	Output current (amps)
B	Alternator speed (rpm)
1	Temperature 0°C (30°F)
2	Temperature 27°C (80°F)
3	Temperature 60°C (140°F)
4	Temperature 93°C (200°F)
5	Temperature 115°C (240°F)

4.2.4 Ignition signal



A run-start/ignition signal is provided as a butt cut wire and is secured to the wiring harness branch behind the footboard of the A-pillar on the left. The wire is white/green in colour and has a current rating of 10 A.

The signal can be used via an external relay for a variety of conversion applications according to the required load.

4.3 Parking aid

Warning note

- To avoid injury, always take care when reversing (R) and when using the sensor system
- The system may fail to detect objects with surfaces that absorb reflections. Always drive with due care and attention
- Traffic control systems, bad weather, air brakes, external motors and fans may affect the proper operation of the sensor system. This may result in poor performance or false alarms
- The system may fail to detect small or moving objects, especially those near the ground
- Changing the tyre diameter or wheel offset may reduce the performance of the active parking aid, and/or the function may not work properly, resulting in injury
- Do not use the system if there are any objects that extend beyond the front and rear ends of the vehicle, such as bicycle carrier accessories. The system will not be able to correct the extra overhangs
- You must remain in your vehicle when the system switches on. It is your responsibility at all times to check your vehicle, monitor the system and intervene if necessary. Failure to exercise due care may result in loss of control of your vehicle and serious personal injury
- The sensors may fail to detect objects in heavy rain or other conditions that cause interference
- You are responsible for controlling your vehicle at all times. The system is designed as an aid and does not relieve you of your responsibility to drive with due care and attention. Failure to follow this instruction may result in loss of control of your vehicle and personal injury

Information

- Keep the sensors clear of snow, ice, and large accumulations of dirt. If the sensors are covered, the accuracy of the system may be adversely affected. Do not clean the sensors with sharp objects
- If your vehicle has damage to the bumper or radiator grille that causes the bumper or radiator grille to be misaligned or bent, the detection range may be altered, resulting in inaccurate measurement of obstacles or false warnings
- Certain additional devices installed around the bumper or trim can create false alarms. For example, large ball couplings, bicycle or surfboard racks, number plate holders, bumper covers, or other devices that may block the system's normal detection zone. Remove the additional device to avoid false alarms
- The parking aid warns the driver of obstacles that are in a specific range of your vehicle. The system switches on automatically when you turn on the ignition. The system can be turned off using the following methods:
 - Via the information display menu
 - Via the pop-up notice that is displayed as soon as you engage reverse gear (R)
 - Via the parking aid button (if present)
- If there is a fault in the system, a driver message appears in the information display. For more information on correct operation of the parking aid, refer to the operating manual for the vehicle
- If possible, parking aid sensors should not be removed from their original X, Y, and Z plane positions. Maintaining the sensor position on these planes is important for proper operation of the system

Position planes of the vehicle

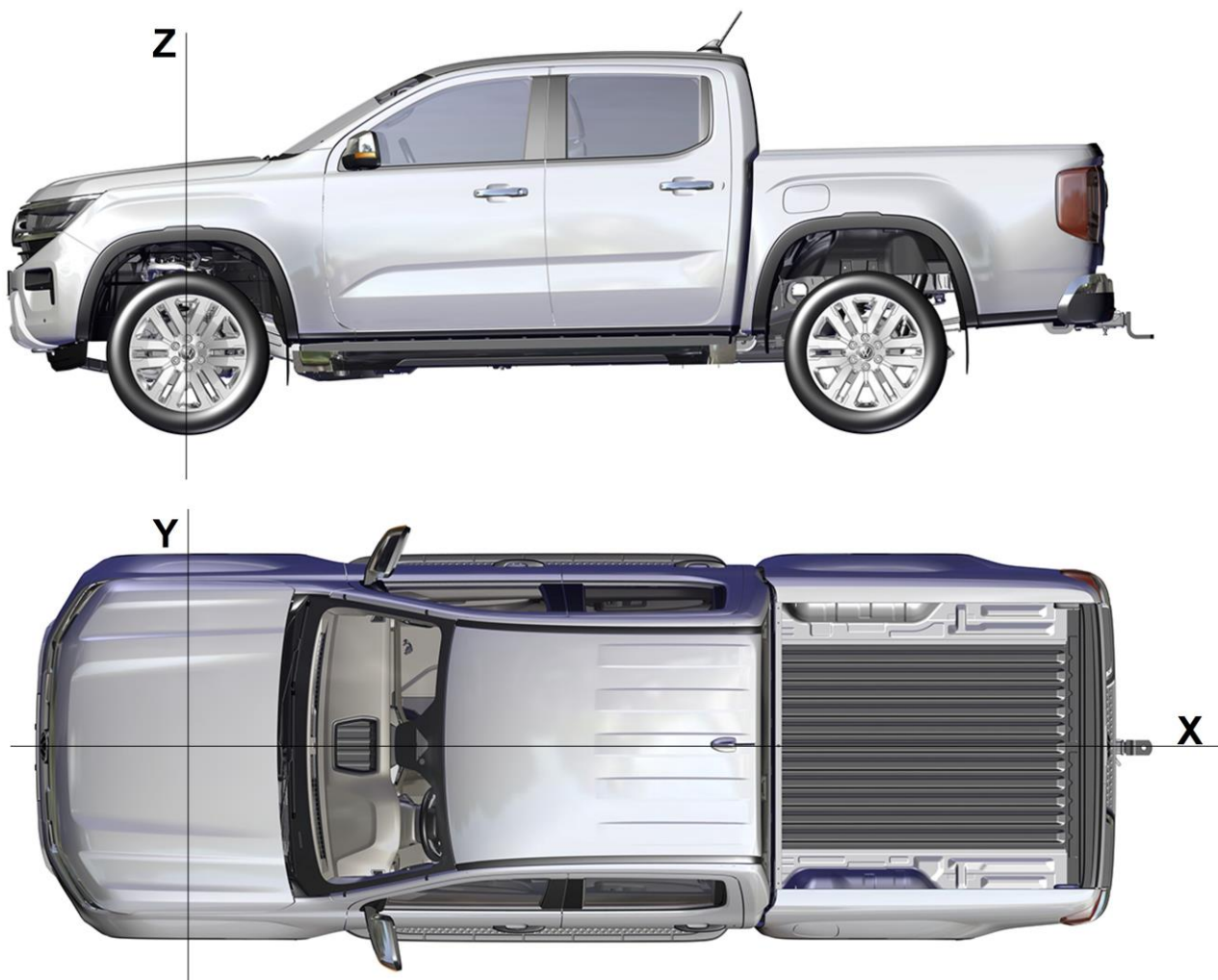

4.3.1 Sensor positions

Information

Displaced sensors must be installed in the same position in which they were originally mounted in the bumper. Make sure that each sensor is installed in the correct position.

Position of the front parking aid sensors



Sensor	Number
Front right outside	1
Front right inside	2
Front left inside	3
Front left outside	4

Position of the rear parking aid sensors



Sensor	Number
Rear left outside	1
Rear left inside	2
Rear right inside	3
Rear right outside	4

Vehicles with Active Park Assist

Warning note

If forward-facing cameras, reversing cameras, side view cameras (mounted in the side-mounted exterior mirrors), and/or parking aid senders are obscured or their position is changed, the parking aid may not function properly, which could result in an accident/injury.

For more information, refer to the operating manual for the vehicle.

4.4 Engine management system

4.4.1 Tachograph

Warning note

Tampering with the CAN (Controller Area Network) and connected components for signal tapping for vehicle speed is not permitted.

A tachograph setup kit is available for installation in vehicles with all-wheel drive. For further information, please contact your authorised Volkswagen Commercial Vehicles partner or importer.

4.4.2 Vehicle speed signal

Warning note

Tampering with the CAN (Controller Area Network) and connected components for signal tapping for vehicle speed is not permitted.

The vehicle speed signal can be obtained from the body control unit. For some models, this output may need to be activated by a Volkswagen Commercial Vehicles partner.

Information

If the vehicle speed drops below 4 km/h (2.5 MPH), the vehicle speed signal may not be detectable for the tachograph.

Properties of the square wave

Specifications	
Maximum level – high signal	Battery voltage
Minimum level – high signal	3.67 V
Maximum level – low signal	1.1 V
Minimum level – low signal	-1.1 V
Max. earth offset	±1.0 V
Rise time	10 μ s \leq tr \leq 250 μ s
Fall time	10 μ s \leq tf \leq 250 μ s
Duty cycle	50% \pm 10%
Pulse frequency	2.2 Hz/MPH (1.3808 Hz/KPH)

Body control unit

The vehicle speed signal can be obtained via the following connector:

- Body control unit J5 (blue connector), pin 41, currently no cable assignment

A wiring harness can be made to detect the vehicle speed signal and inserted at the body control unit connector. (0.5 mm² cable recommended)

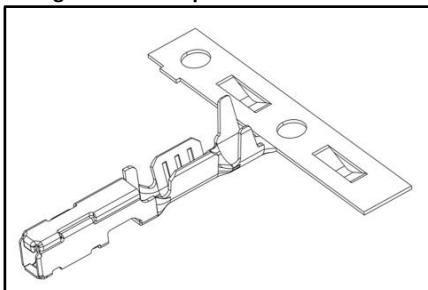
Wiring harness clamp**Information**

The wiring of the vehicle speed signal should be shielded and twisted to reduce EMC effects.

4.5 Information and infotainment system

4.5.1 Reversing camera

Aftermarket reversing camera – direct connection to SYNC*

Information

- The display does not have a direct input for connecting devices such as cameras. Only vehicles with *SYNC radio support retrofitting of a reversing camera
- The SYNC module has three pins:
 - C1-14: input camera – rear parking aid video (+)
 - C1-15: input camera – rear parking aid video (-)
 - C1-33: earth: rear parking aid camera video
- The cable between the reversing camera and the SYNC module must be shielded and twisted, preferably in one piece to minimise signal loss
- In addition, certain parameters of the vehicle must be reconfigured. This must be done at an authorised Volkswagen Commercial Vehicles partner or importer in order not to void the guarantee
- The display only provides information on the reversing camera when reverse gear is engaged

Rear brake assist system

Information

- Do not paint or modify the reversing camera or the rear bumper as this will affect the function of the rear brake assist system
- The reversing brake assist system does not support modifications to the power steering system
- The reversing brake assist system does not support modifications to the traction control system or the anti-lock brake system
- Modifications to the door locking system or removal of doors may interfere with reversing brake assist system
- Installing accessories on the rear of the vehicle will interfere with the functions of the reversing brake assist system. In these cases, the function should not be used. Incorrect reversing brake assist events may occur
- Do not cover the reversing camera

All cameras

Information

- Do not move or change any camera mounting positions or brackets as this will have an adverse effect on the functionality of the camera and the rear brake assist system
- Do not disconnect or remove any cameras mounted on the vehicle
- Do not obstruct any part of the reversing camera's field of view
- Any object mounted within the field of view cone of the front camera and exterior mirror cameras will obstruct the visibility of the 360 degree camera

360° camera

Information

- Any change to the track will cause the dynamic guidelines to be unrepresentative of the vehicle's turning circle
- Any object mounted within the field of view cone of the front camera and exterior mirror cameras will obstruct the visibility of the 360 degree camera

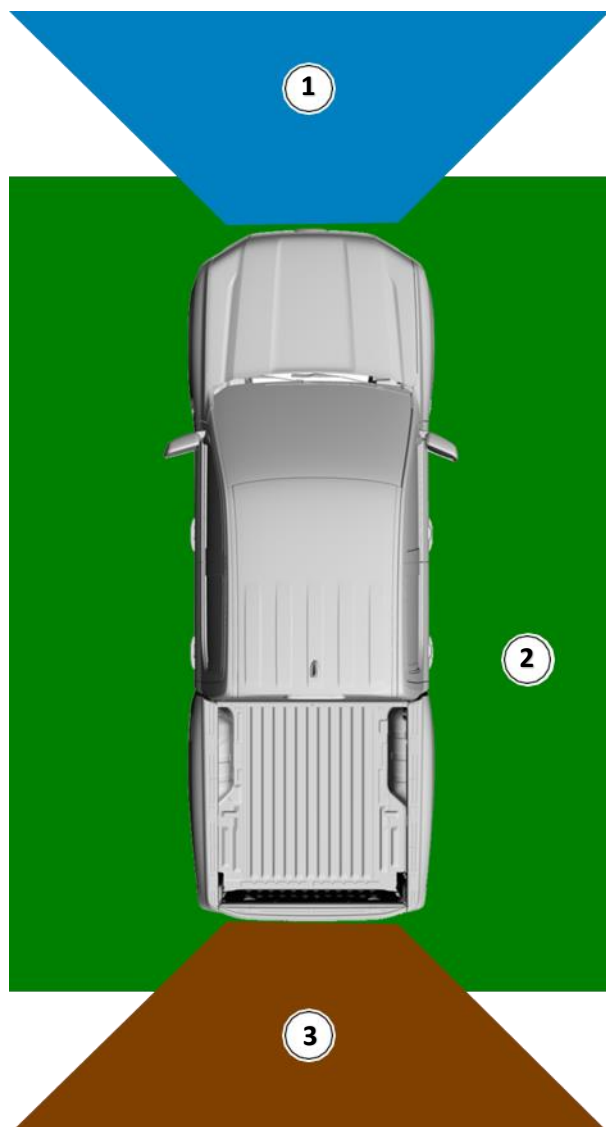

1 – Field of view of the front camera

2 – 360° camera field of view

3 – Field of view of the reversing camera

Front camera – restrictions of the front protective strip

Warning note

Do not move or change the camera mounting positions or brackets as this will interfere with the camera and reversing brake assist system.

Information

- Any object mounted within the field of view cone of the front camera and exterior mirror cameras will obstruct the visibility of the 360 degree camera
- Fitting accessories on the front rail that interfere with the front camera's field of view will obstruct some of the camera video and cause an incomplete or degraded 360-degree view
- Any change to the track will cause the dynamic guidelines to be unrepresentative of the vehicle's turning circle

Vehicles equipped with analogue reversing camera

Information

- Do not move or change any camera mounting positions or brackets as this will have an adverse effect on the functionality of the camera and the rear brake assist system
- No part of the reversing camera's field of view cone may be negatively affected
- Any change in the height of the vehicle will result in the guide values for the reversing camera not being representative of the distance of the vehicle width to the vehicle
- Any change to the track will cause the dynamic guide values to be unrepresentative of the vehicle's turning circle

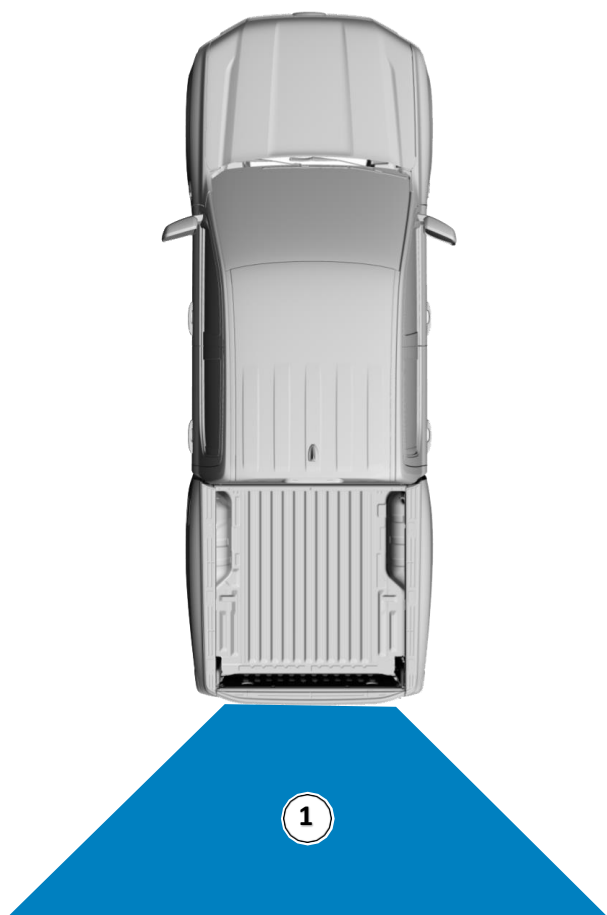

1 – Field of view of the reversing camera

4.6 Exterior lighting

Warning note

- Make sure that the modified vehicle complies with the approval regulations and legal requirements applicable in the market
- Make sure that all electrical connections and wiring comply with local regulatory standards

Information

- Before performing any work on a vehicle, it is important to identify the vehicle equipment (simple or enhanced equipment) by the type of electrical architecture fitted in the vehicle in question. Failure to identify the type of electrical equipment on the vehicle before performing the work may result in electrical damage or safety issues.
See also [chapter 4.13 “Fuses and relays”](#).

4.6.1 Rear combination lights

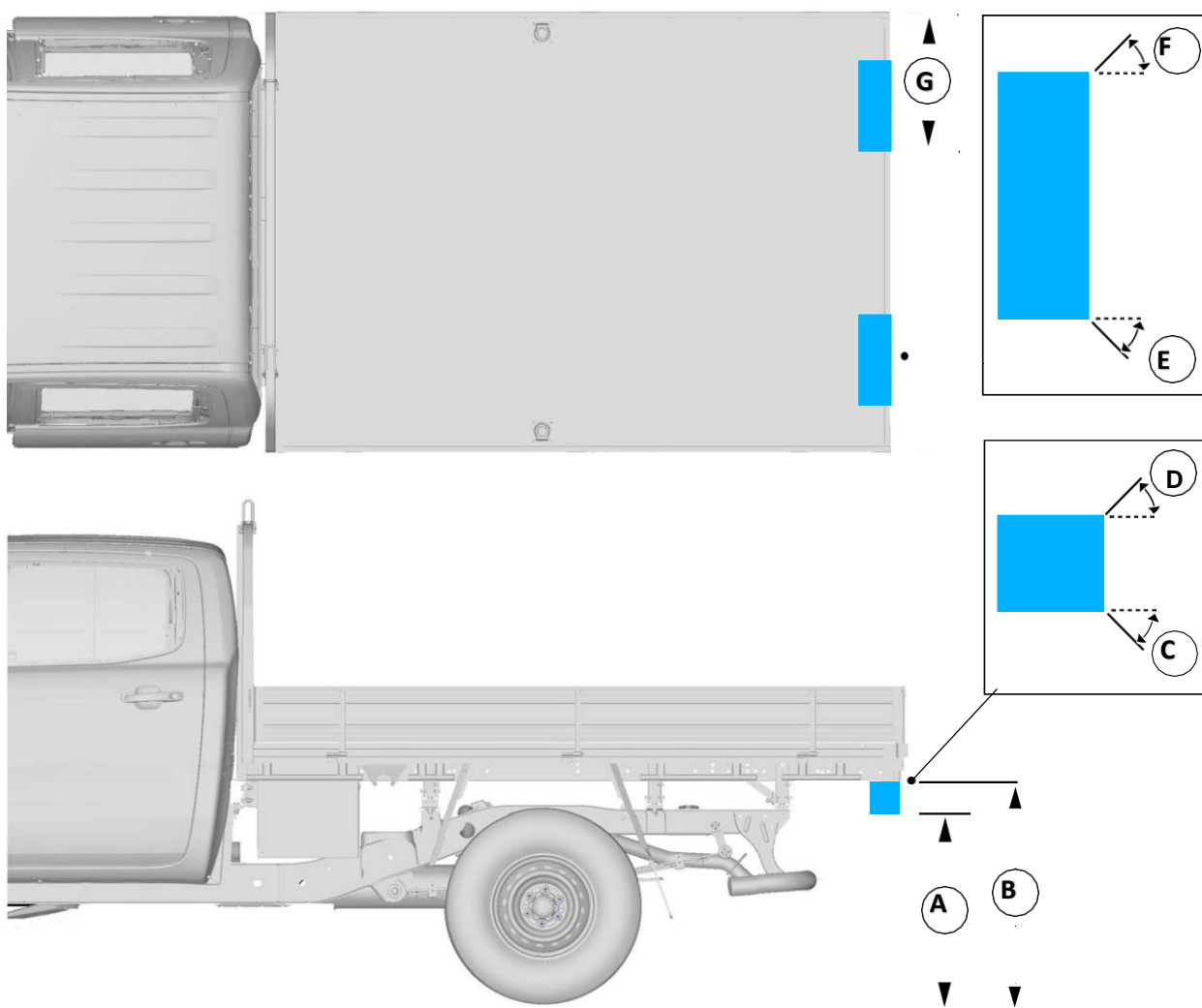

Positioning of rear combination lights

Description		Dimensions
A	Minimum distance from the ground to the lower edge of the light	250 mm
B	Maximum distance from the ground to the upper edge of the light	1200 mm
C	Minimum angle of the obstacle-free zone up to the bottom of the light	15°
D	Minimum angle of the obstacle-free zone above the light	15°
E	Minimum angle of the obstacle-free zone to the outside of the vehicle	80°
F	Minimum angle of the obstacle-free zone to the centre of the vehicle	45°
G	Maximum distance from the outer edge of the vehicle to the inner edge of the light	400 mm

4.6.2 Rear fog light

Information

If there is only one rear fog light, it must be positioned on the centre line of the vehicle or on the driver side of the vehicle.

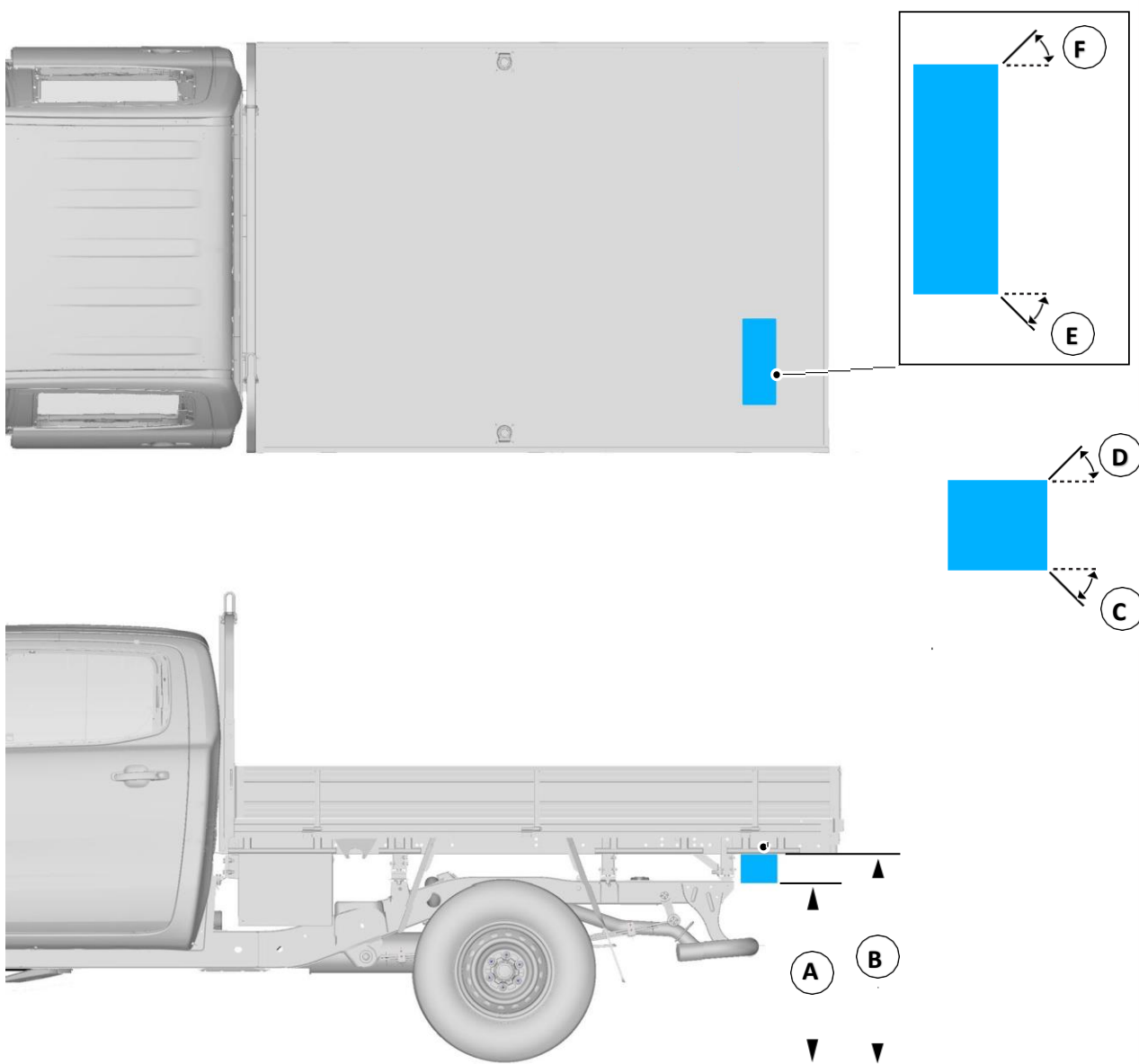

Positioning of the rear fog light

Description		Dimensions
A	Minimum distance from the ground to the lower edge of the light	250 mm
B	Maximum distance from the ground to the upper edge of the light	1000 mm
C	Minimum angle of the obstacle-free zone under the light	5°
D	Minimum angle of the obstacle-free zone above the light	5°
E	Minimum angle of the obstacle-free zone to the outside of the vehicle	25°
F	Minimum angle of the obstacle-free zone to the centre of the vehicle	25°

4.6.3 Rear number plate lights

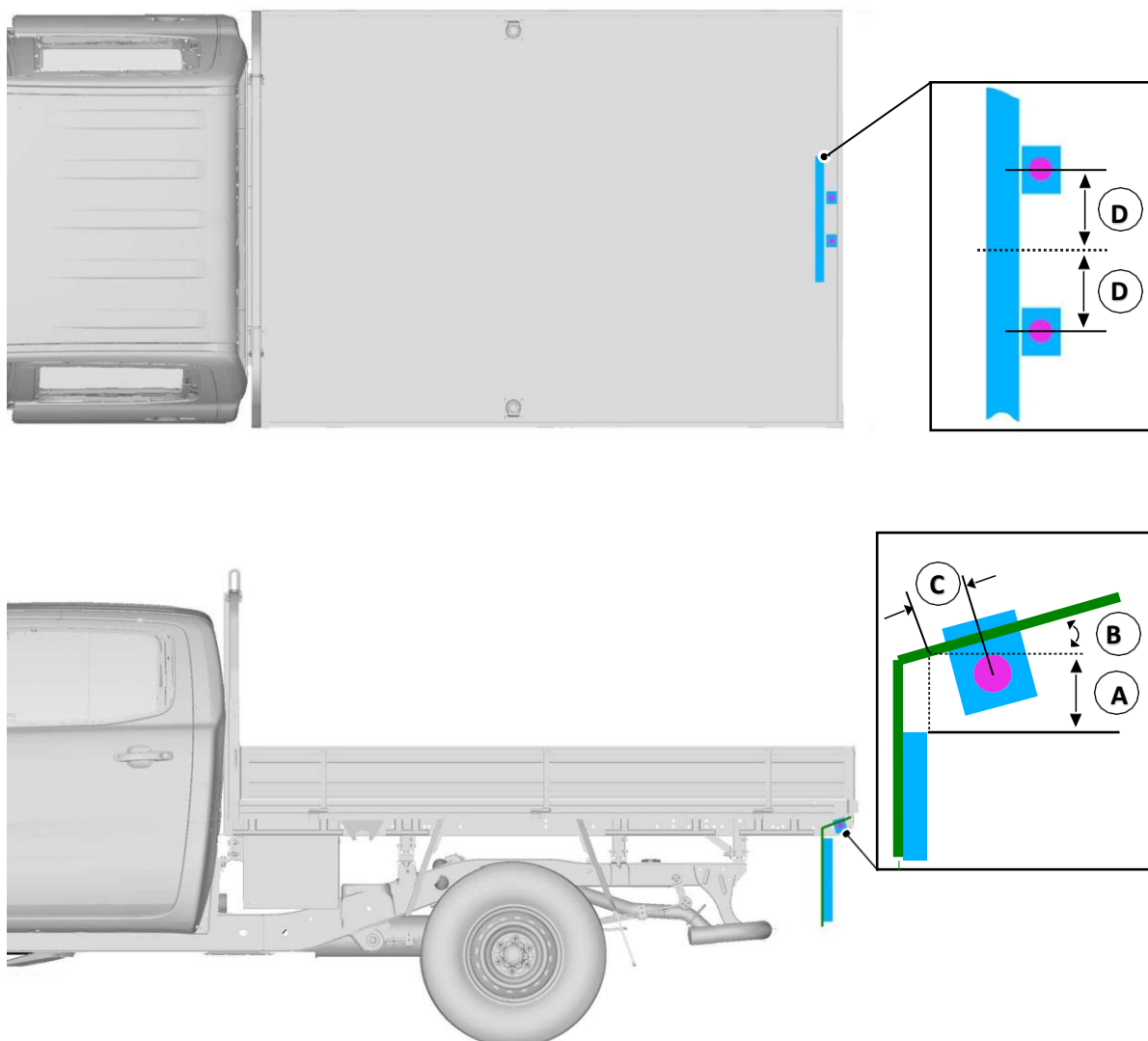

Positioning of the rear number plate light

Description		Dimensions
A	Distance from rear panel of number plate light to centre of light Along the light mounting side	35 mm
B	Angle between number plate light and light mounting side	8°
C	Distance between the top edge of the rear of the number plate and the light mounting surface	35 mm
D	Distance between the centre line of the number plate and the centre of the lights	One quarter of number plate width (min. 90 mm, max. 175 mm)

4.6.4 Additional exterior lights

Warning note

Connecting auxiliary headlights or other electrical devices directly to the vehicle wiring can overload the system and affect the operation of other vehicle systems.

Volkswagen Commercial Vehicles recommends that when additional tail light clusters are installed, power should be supplied through the trailer towing module and associated circuits. For all other additional exterior lights, power must be supplied through an additional fuse box with a suitable switch and/or relay, as required.

When auxiliary main headlights are installed, power may be supplied through a relay powered from the headlight supply.

4.6.5 Headlights – connecting an additional main beam signal

The connection of additional electrical equipment, e.g. for activating real operated main beam circuits, can be supported.

There are two versions of headlights available.

Information

Left headlight shown, right headlight similar.

Identifying the headlight level

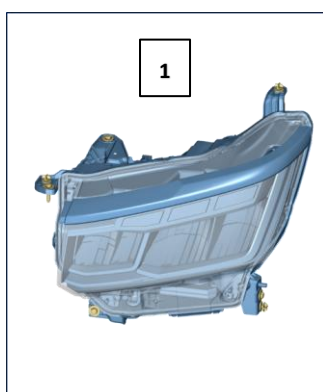

1 LED headlights (PR no. 8EX)

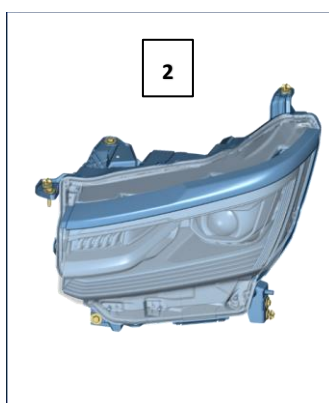

2 "IQ.Light" matrix LED headlights (PR no. 8IT)

The connection of additional electrical equipment for activating a relay for solutions such as activating the main beam varies depending on how the vehicle is equipped with headlights.

Connecting additional electrical equipment – vehicles with LED headlights (PR no. 8EX)

LED headlights – dipped beam

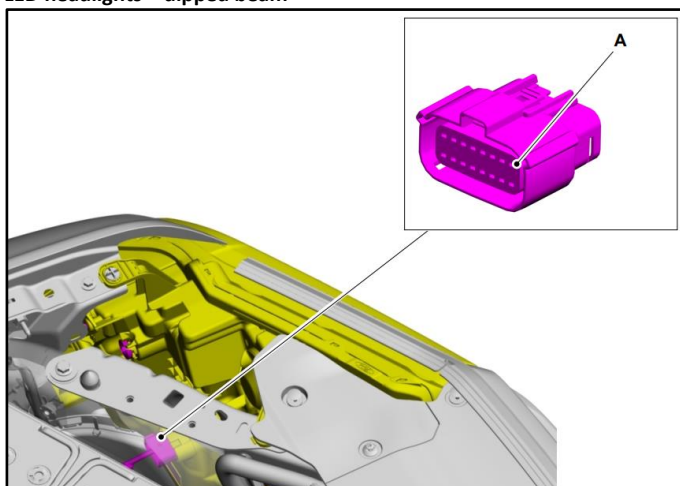

Item	Description
A	Dipped beam = connector T16bs, PIN 1

Signals are available on the wiring harness side.

LED headlights – main beam connection

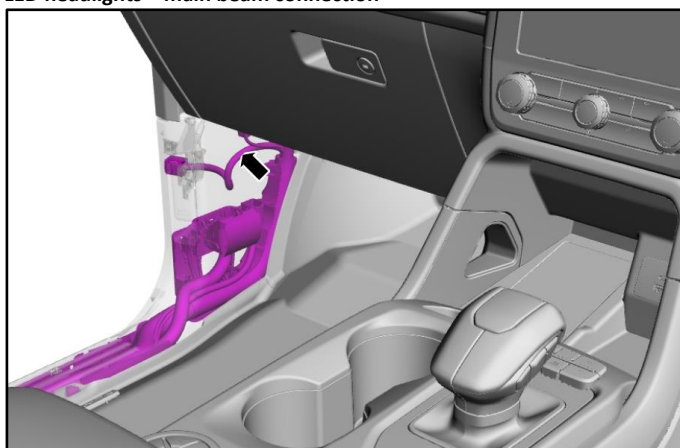

Practical note

It is not permitted to connect additional electrical equipment directly to the main beam wiring of level 2 headlights. Doing so may result in damage to the headlight control system.

Information

Right-hand drive vehicle shown, left-hand drive vehicle similar.

Additional electrical equipment that is triggered by switching on the level 2 main beam is connected via a pre-installed butt cut cable located in the front passenger footwell behind the tread surface on the main wiring harness. A butt cut cable is marked for such a connection.

The signal can be used via an external relay for a variety of conversion applications according to the required load.

- Cable colour grey/brown (GY/BN) – 6 A

Headlight fuse

Lighting fuses		
F-100	20 A	Left/right headlights

Connecting additional electrical equipment – vehicles “IQ.Light” matrix LED headlights (PR no. 8IT)

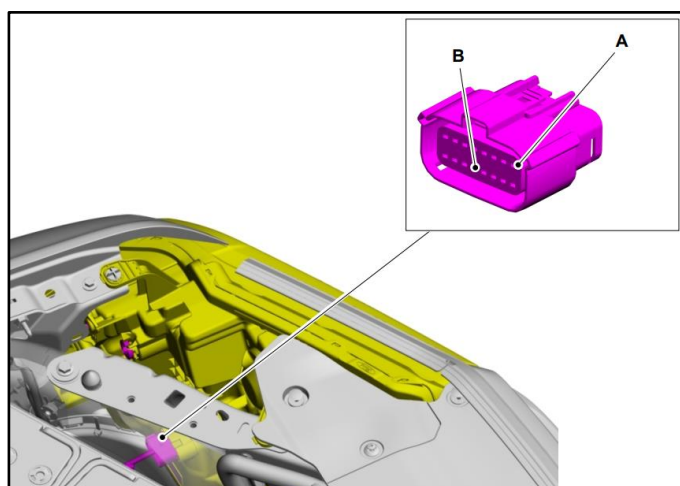

Item	Description
A	Dipped beam = connector T16n PIN 1
B	Main beam = connector T16n PIN 13

The dipped beam signal (A) is available on the wiring harness side. The main beam signal (B) is only available on the headlight side. There is no cable on the wiring harness side. If necessary, insert the appropriate terminal and the connection cable.

Information

The dazzle-free main beam function does not switch off this signal output of the main beam. Under these conditions, manual operation of a connected additional light would be required. This signal is only output if the headlights are in the dipped/dipped beam or main beam stages.

The signal can be used via an external relay (according to the required load) for a variety of conversion applications.

Headlight fuse

Lighting fuses		
F-100	20 A	Left/right headlights

4.6.6 Brake lights

Additional brake lights are connected via a butt cut cable located near the centre high mounted brake light. The butt cut cable can carry a current load of 1.75 A at steady state (at 13.5 V).

4.6.7 Side marker lights (parking lights)



A side marker light (parking light) signal is available as an open wire, which is fastened to the wiring harness behind the footwell cover on the LHS A-pillar with adhesive tape.

- Cable colour blue/grey (BU/GY) – 4.7 A

4.6.8 Reversing lights, reversing camera, reversing alarm (manual gearbox)

The reversing lights are activated by the reversing switch on the gearbox. A small increase in current (via a relay or buffered electrical input) is permitted to provide power to a reversing camera, auxiliary reversing lights, or audible warning device.

4.6.9 Towing mode – lighting connections

Warning note

Installing retrofit kits for the trailer electrics or connecting directly to the vehicle wiring to install trailer lights or other electrical devices may overload the system and adversely affect the operation of other vehicle systems.

See: [2.2.3 Overrun brake connection](#)

Volkswagen Commercial Vehicles recommends using the Genuine Accessories trailer kit for all trailer electrical connections.



A trailer brake signal may be available as an open wire that is located on the wiring harness behind the footwell cover on the lower section of the left A-pillar and is secured with adhesive tape.

- Cable colour yellow/grey (YE/GY) – 2.1 A

Trailers equipped with LED lights (light emitting diodes)

Most trailers, caravans, camper vans etc. are now equipped with LED lights. They are available in a wide range of sizes, configurations and quality.

The trailer module (TTM) can support LED trailer lights, provided each circuit exceeds a current draw of 500 mA; if the current draw is lower, the system will not detect a coupled trailer and will turn off all outputs (sleep mode). It is recommended to design for a minimum load of 550 mA in order to take system tolerances into account.

If the LED lights on the trailer are outside the specific tolerances, customers can experience the following symptoms in the vehicle when the LED trailer lights are connected to the vehicle:

- LED trailer lights flicker when the lights are not in use
- DAT (driver assistance technology) is not deactivated
- Rear park sensors (if fitted) are continuously triggered in reverse gear when a trailer is coupled to the vehicle
- Vehicle DOES NOT detect that a trailer has been coupled (either by an icon on the middle screen OR a message on the multi-function display of the instrument cluster)
- The warning “Check trailer parking lights” or “Check trailer brake lights” is displayed on the multi-function display of the instrument cluster

To remedy this, additional load resistors must be used to comply with the tolerances for the target system.

Practical note

Do not connect the adapter cable to the vehicle if no trailer is coupled.

Information

To resolve these problems, use a RESISTOR PATCH WIRING HARNESS between the vehicle and the trailer (12-pin example below).

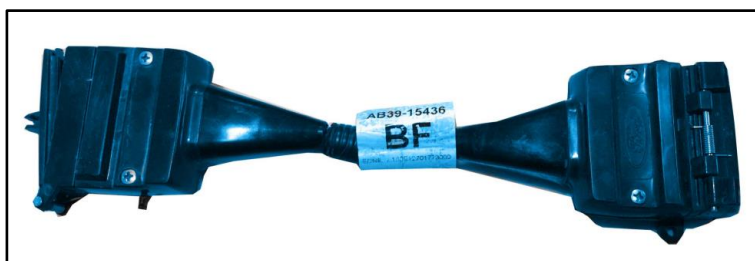

The resistor patch wiring harness consists of multiple 2 W, 120 ohm resistors, as shown in the following wiring diagram. This could also be directly integrated into the trailer-side wiring if a more permanent solution is desired. Do not apply this to the vehicle-side wiring. This should only be effective if a trailer is connected.

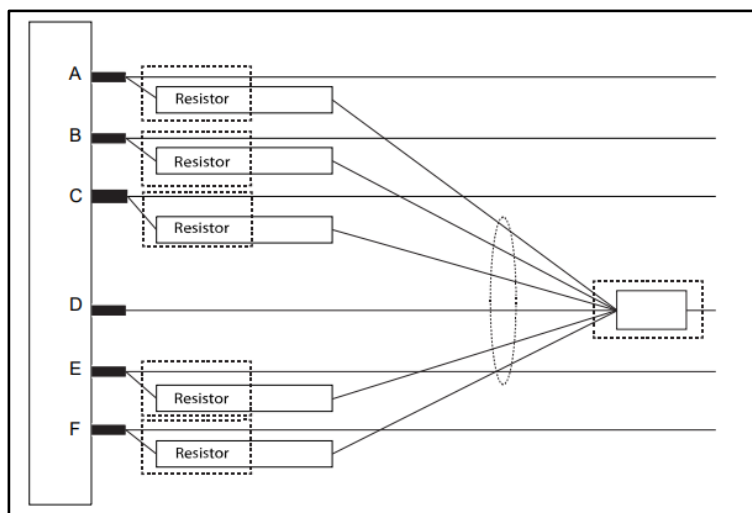

Item	Description
A	LH turn signal
B	RH turn signal
C	Stop/brake lights
D	Earth
E	RH tail light (if applicable)
F	Tail lights (all or, if necessary, LH)

Connecting the trailer coupling lights – system recommendations

Information

Not all functions and outputs are supported in all markets. Contact your authorised Volkswagen Commercial Vehicles partner or importer for further information.

Information

The trailer detection circuit is integrated into the Volkswagen trailer module. It can only be used on vehicles with central locking and an anti-theft alarm system with no interior monitoring or CAT-1 alarm.

Practical note

The individual current drivers can each supply a current of 15 A, but operation with this maximum value is not recommended. A higher current is interpreted as a short circuit. If a short circuit is detected in a connected output, the output is deactivated. The following table shows the recommended maximum output capacitance per circuit.

Trailer towing module connections

Component terminal number	Function	Current (A)		Voltage (V)	
		Min	Max	Min	Max
Connection A					
1	Left turn signal	0.5	3	6	-
2	Right turn signal	0.5	3	6	-
3	Side marker light	0.5	7	6	-
4	Not used	-	-	-	-
5	Reversing light	0.5	4	6	-
6	Battery charge output – where used	-	15	9	16
7	Brake lights	0.5	4	6	-
8	Fog lights	0.5	2	6	-
9	Not used	-	-	-	-
10	Not used	-	-	-	-
11	Not used	-	-	-	-
12	Not used	-	-	-	-
Connection B					
1	B(+) fuse 87 (40 A) BJB	-	-	-	-
2	B(+) fuse 73 (30 A) BJB	-	-	-	-
Connection C					
1	Earth	-	1	6	-
2	CAN L	-	0.1	6	-
3	CAN H	-	0.1	6	-
4	Not used	-	-	-	-

For vehicles that were delivered without a ball coupling, an original Volkswagen trailer electrical connection parts set is available to enable ball coupling to be retrofitted. The kit consists of the ball coupling control unit, trailer connector, wiring and associated fasteners. After the kit is installed, the vehicle must be configured with a Volkswagen DRS diagnostic tool. This configuration can be carried out by a Volkswagen Commercial Vehicles partner.

4.6.10 Lights – hazard warning lights / turn signals

The maximum allowable load with the standard system is:

- 3 x 5 W – front and rear turn signals + side turn signals (left side)
- 3 x 5 W – front and rear turn signals + side turn signals (right side)

Information

- The maximum output power of the turn signal onboard supply control unit outputs is 3.2 A
- Flashing/warning indicator signals are available as an output of the onboard supply control unit

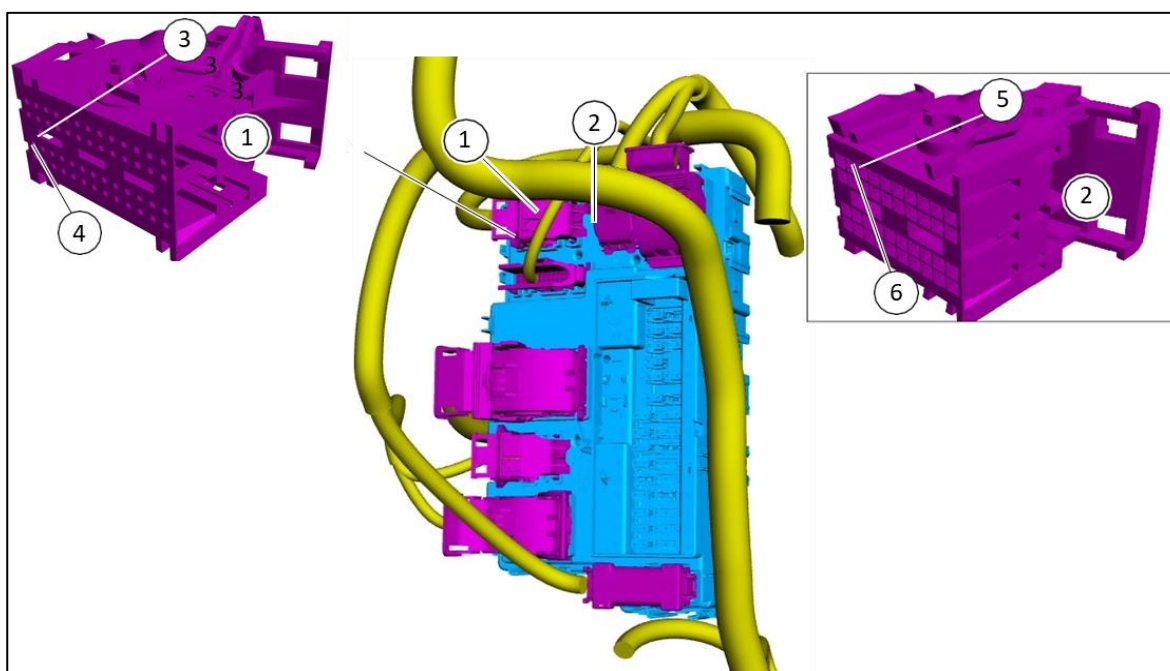

Item	Description
1	Onboard supply control unit connector T52d
2	Onboard supply control unit connector T40a
3	Rear right rear turn signal output = onboard supply control unit connector T52d pin 52
4	Rear left rear turn signal output = onboard supply control unit connector T52d pin 26
5	Rear right front turn signal output = onboard supply control unit connector T40a pin 38
6	Rear left front turn signal output = onboard supply control unit connector T40a pin 39

4.6.11 Electrically operated exterior mirrors

Warning note

Do not tamper with the base system (which is controlled by the central distribution box and multiplex architecture) and any feeds taken from the corresponding wiring or control unit.

Information

These options are not suitable for retrofits or conversions.

4.6.12 High-mounted centre brake light

Information

- When renewing the factory-fitted centre brake light with a centre brake light fitted to the hardtop, the same type must be used. Renew a bulb/incandescent lamp only with a bulb/incandescent lamp. Renew an LED light unit with an LED light unit only
- The maximum current load that can be applied to the brake light circuit is 2.5 A for incandescent bulbs or LED light units. Do not exceed the rated load
- The use of high mounted centre brake lights must comply with ECE R48-04 or local regulations
- When a centre brake light is installed, it may be powered by the onboard supply control unit (connector T52d pin 13)

4.6.13 Main beam assist

Information

- The automatic main beam will not function or its performance may be adversely affected if there is a conversion or installation in the field of view of the front camera
- The automatic main beam will not function or its performance may be adversely affected if the ride height of the vehicle is increased or decreased, or the tilt of the vehicle is changed
- Note that if the headlight switch is not in the Auto position (or Auto is not selected on the original switch), the automatic main beam system (in conjunction with the front camera) will not be available or displayed in the dash panel insert

4.6.14 Glare-free main beam

Information

- The dazzle-free main beam will not function or its performance may be adversely affected if the ride height of the vehicle is increased or decreased, or the tilt of the vehicle is changed
- The dazzle-free main beam will not function or its performance may be adversely affected if there is a conversion or installation in the field of view of the front camera
- Note that dazzle-free main beam (supplied with the front camera) will not be available or displayed in the dash panel insert if the Auto position of the headlight switch is not available (or Auto is not selected on the original switch)

4.6.15 Parking brake signal

Information

No handbrake signal is available on vehicles with an electric parking brake (EPB). This system is controlled via CAN.

4.7 Cruise control system

4.7.1 Adaptive cruise control

Information

- Do not obscure the cruise control system's radar. Any obstruction may prevent the radar from detecting objects in front of the vehicle
- Do not paint the front grille of the vehicle as this may interfere with the functionality of the cruise control radar. Different paint types and colours may have different effects on the radar beam and performance cannot be guaranteed
- Do not change the design of the lower radiator grille as this will have an adverse effect on the performance of the cruise control module
- Do not change the position of the radar as this will drastically affect the performance of the cruise control module and its ability to reliably detect objects
- Do not change the mass or shape of the radar in a way that changes the radar spacing. Any change in radar spacing degrades the efficiency of the cruise control module by reducing either the maximum detection range of the radar, its ability to detect high or low targets, or its ability to detect objects without obstruction
- Do not modify or remove the radar cover as this will affect radar performance. This cover is specifically designed to have minimal interference with the radar beam. Removing the cover opens the radar to environmental factors such as rain, snow and mud. Radar performance and long-term durability cannot be guaranteed

Warning note

For converted vehicles with adaptive cruise control where the vehicle mass or geometry is significantly changed, Volkswagen recommends that you have the functionality of the radar's vertical alignment system checked, and if necessary recalibrated, by a Volkswagen Commercial Vehicles partner or importer. For more information, refer to the operating manual for your vehicle.



1 Adaptive cruise control module

2 Adaptive cruise control radar clearance zone

4.8 Driver assist systems

Warning note

Changes that affect the operation and alignment of driver assistance technologies can cause the system to malfunction and increase the risk of traffic accidents/injuries.

The driver assist system includes a number of driver assistance technology features that utilise a radar and/or camera system. The radar and camera systems support features such as:

- Autonomous Emergency Braking Front Assist with Pedestrian and Cyclist Monitoring
- Collision warning
- Lane departure warning – Lane Assist
- Lane change assist – Side Assist
- Main beam assist – Light Assist
- LED Matrix (dazzle-free main beam)
- Adaptive Cruise Control – Stop & Go
- Overhead view camera – Area View
- Adaptive cruise control system with stop & go and lane guidance

Blind Spot Monitor and Cross Traffic Alert with cross-traffic warning, trailer monitoring and lane change warning.

Practical note

If the radar and cameras are disconnected and the vehicle battery is also disconnected during conversion work, the radar and cameras must be reconnected before the vehicle battery is reconnected. Failure to follow these steps will result in error lights and error codes, and you may need to visit a Volkswagen Commercial Vehicles partner to have these error codes removed.

The radar and camera monitoring zones must not be impaired by add-ons/modifications.

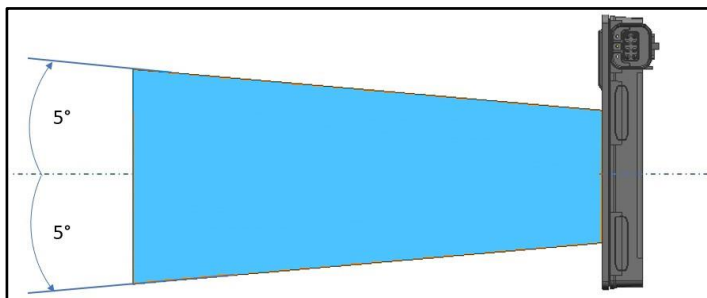
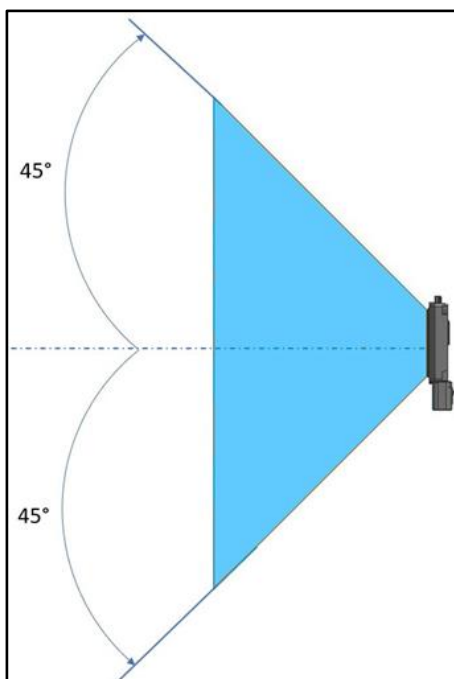
Radar monitoring zone – side view**Radar monitoring zone – top view**

For more information on the driver assist systems, refer to the Owner's Manual.

Installed retrofit equipment must not impair the radar and camera view zones. A template for creating a physical distance zone is also shown below.

Template for radar view zone

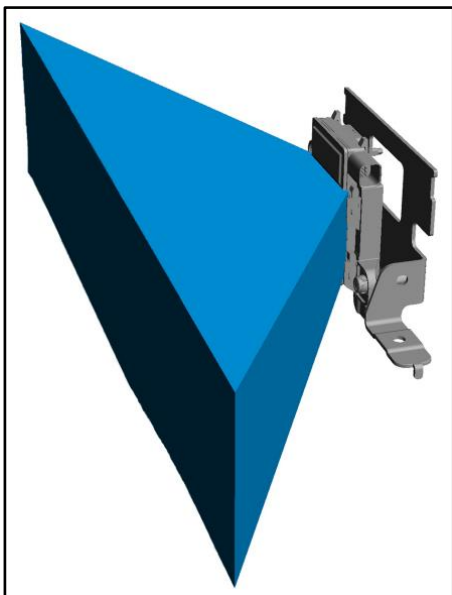

Dimensions of template for radar view zone

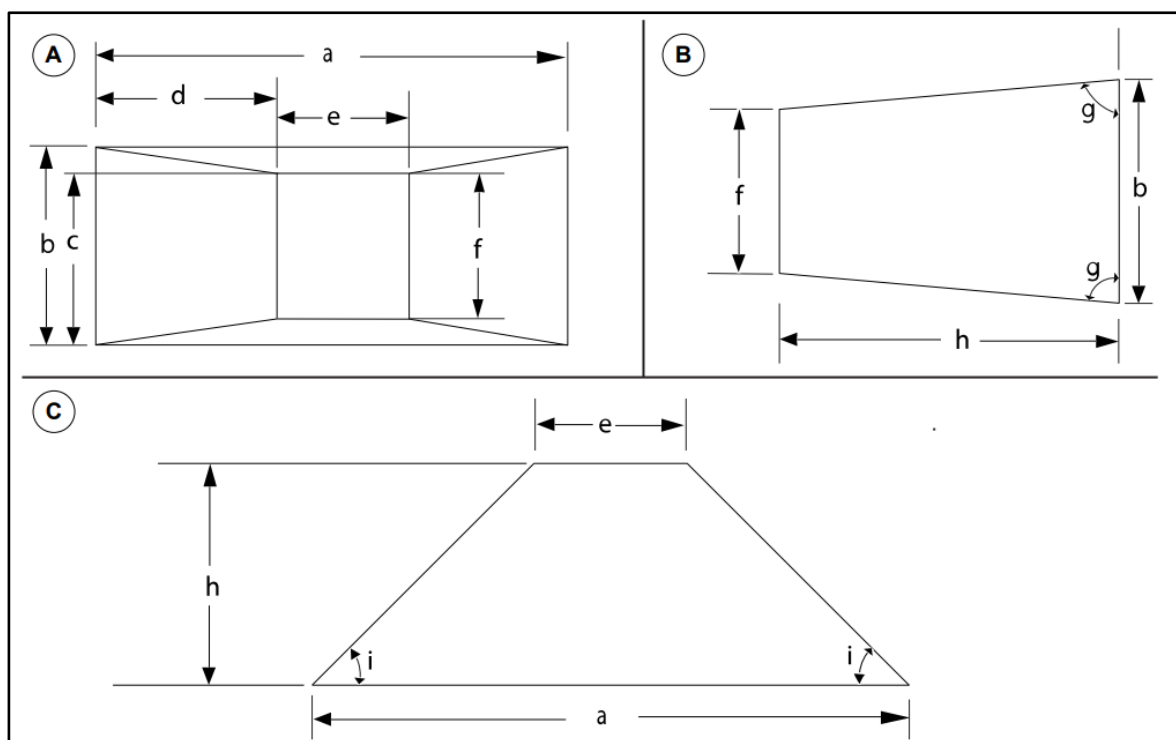

Dimensions	
A	Front view
B	Side view
C	Top view
a	400 mm
b	90 mm
c	75 mm
d	167 mm
e	67 mm
f	60 mm
g	85°
h	167 mm
i	45°

Camera view zone – top view

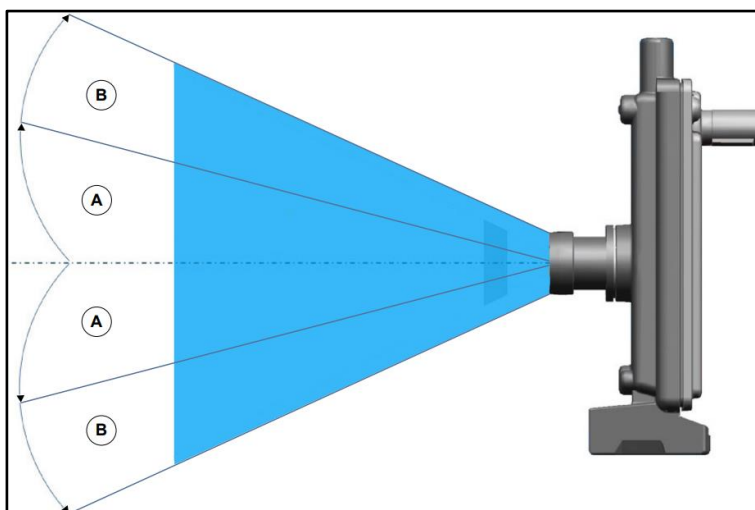

Item	Description
A	26° – without active cruise control
B	50° – with active cruise control

Camera view zone – side view

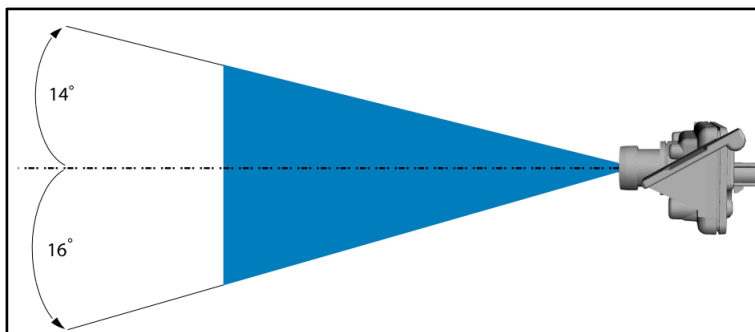

For more information on the driver assist functions, refer to the Owner's Manual for the vehicle.

4.9 Overhead view camera – Area View

Practical note

For converted vehicles that are equipped with the Area View overhead view camera and the Rear Traffic Alert system where the vehicle mass or geometry is significantly changed, we recommend checking the vertical alignment of the radar. For more information, contact your Volkswagen Commercial Vehicles partner or importer.

Information

- Do not apply decals / repair compound to these areas as this may adversely affect the performance of the system and block or obstruct the radar beam
- The Area View overhead view camera can switch on in heavy rain and issue warning messages even though no vehicle has entered the area that cannot be seen
- If the tail light clusters are changed, the Area View overhead view camera and the Rear Traffic Alert may issue false warnings or fail to detect objects
- If the radar beam is blocked or obstructed, the Area View overhead view camera and Rear Traffic Alert may issue false warnings or fail to detect objects
- If your vehicle has a ball coupling with a factory-equipped trailer tow module and is towing a trailer, the sensor will automatically switch off the Area View overhead view camera and Rear Traffic Alert if you do not set up and select a valid trailer in the trailer menu
- If your vehicle has a ball coupling but **not** a factory-equipped trailer tow module, we recommend that you manually switch off both Area View and Rear Traffic Alert. Operating the Area View overhead view camera feature with a trailer attached but without the Area View trailer towing package will result in incorrect warning messages

Area View overhead view camera position



Item	Description
1	A control unit for the lane change assist and sensors for the overhead view camera are located in the left-hand bumper corner
2	A control unit for the lane change assist and sensors for the overhead view camera are located in the right-hand bumper corner

4.10 Side view camera

Warning note

You are responsible for controlling your vehicle at all times. The system is designed as an aid and does not relieve you of your responsibility to drive with due care and attention. Failure to follow this instruction may result in loss of control of your vehicle and personal injury.

Practical note

The 360 degree camera system still requires the driver to maximise visibility by looking out the windows and checking the interior and exterior mirrors.

Side cameras, located on the underside of the exterior mirrors, are part of the 360 degree camera system. Any modification to the exterior of the vehicle should ensure that the function and installation position of the side view cameras are not affected.



1 Position of the side view camera

Side view camera viewing areas

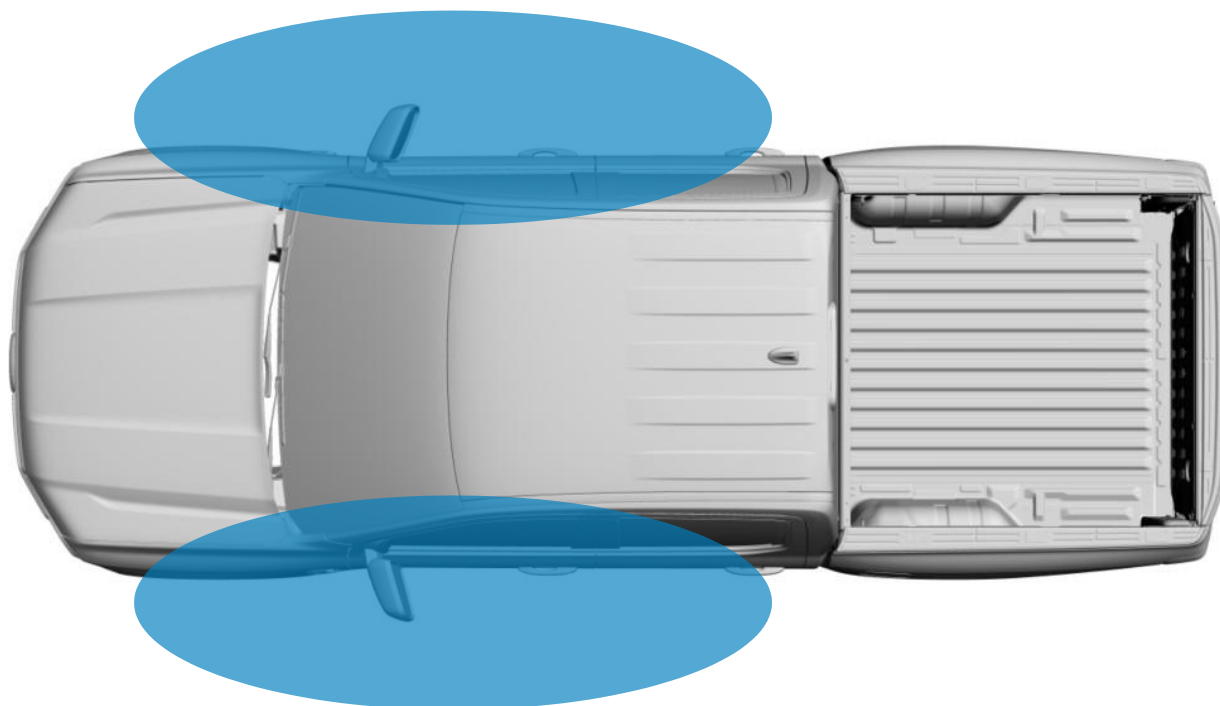

4.11 Lane departure warning (Lane Assist)

Information

- The lane departure warning function does not work if there is a conversion or installation in the field of view of the lane departure warning system's camera
- For converted vehicles equipped with the lane departure warning system where the vehicle mass or geometry is significantly changed, the camera must be recalibrated. Contact your Volkswagen Commercial Vehicles partner or importer
- The lane departure warning system will not function or its performance may be adversely affected if the ride height of the vehicle is increased or decreased, or if the tilt of the vehicle is changed
- The lane departure warning system will not work, or performance may be adversely affected, if the vehicle's track width is changed

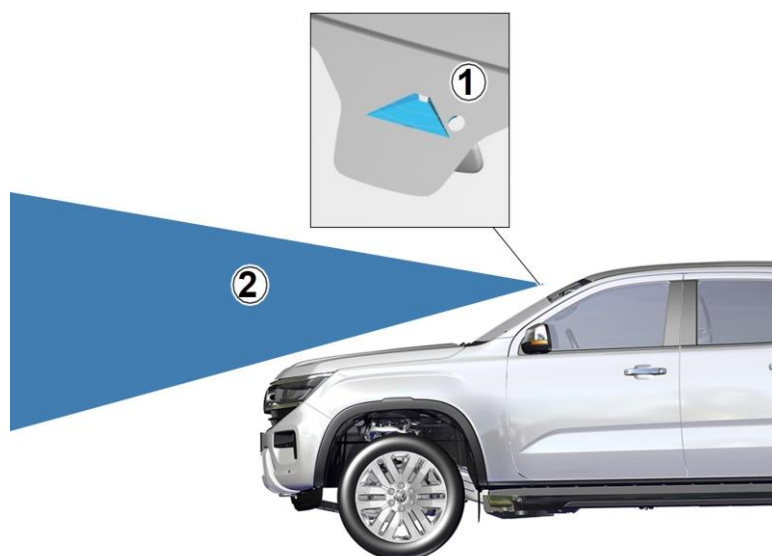

Item description	
1	Lane departure warning – camera behind the interior trim of the interior rear view mirror
2	Field of view of the camera

For more information, see the [section on adaptive cruise control in chapter 4.7.1](#)

4.12 Handles, locks, catches and access systems

4.12.1 Central locking system

Information

- Additional locks are not covered by the vehicle's car alarm
- The central locking function is controlled by the BCM* (*onboard supply control unit, under the dash panel). The vehicle locks are powered by field effect transistors (FETs) in the onboard supply control unit – these are only capable of powering one lock each
- It is possible to add one or more additional locks using relays that are actuated by the onboard supply control unit outputs
- The location of additional relays should be carefully considered. A suitable mounting location away from the passenger compartment will allow for safer installation and reduced noise in the vehicle interior
- Depending on the functionality required, the pins used emulate the basic locking/unlocking operation of an existing lock. The coil of the additional relays (i.e. one relay for locking, one relay for unlocking all relays) should be added via the appropriate pin and a suitable earth point. The power (B+) for the additional relays should be taken from an appropriately fused B+ feed
- The relays for installing one or more additional locks must be selected in parallel to the duration of the surface mounted onboard supply control unit relays

Onboard supply control unit output for central locking system

Onboard supply control unit connector	Pin	Function
T36a	35	CTRL MOD. – DOOR LOCK # ALL LOCKED
T36a	32	CTRL MOD. – DOOR LOCK # UNLOCK ALL

4.13 Fuses and relays

4.13.1 Fuses

Information

For information on the position and ratings of the fuses, refer to the operating manual.

5 Body and paint

5.1 Body

5.1.1 Body structures – general information

Warning note

- Cutting, drilling or welding on components relevant to crash behaviour is not permitted
- Changes to the body must not impair the function and strength of the vehicle's units and operating devices, and they must not reduce the strength of weight-bearing parts
- The converter shall ensure that all modifications comply with general product safety requirements, legal provisions and type approvals

Practical note

During vehicle conversions and the assembly of bodies, it is not permitted to make any modifications which impair the function and freedom of movement of the suspension (e.g. for maintenance and inspection work) or the accessibility to the same

Please note that the side panels of the factory-designed cargo box are not intended for connecting heavy add-on parts. Add-on parts must always be fastened to the intended load points/lashing points on the base of the cargo box. Strength calculations must be carried out and, if necessary, appropriate reinforcement measures must be provided

See also [chapter 1.11 "Assemblies and ergonomics"](#).

Practical note

Uneven load distribution may result in unacceptable driving and braking characteristics.

When performing vehicle conversions/modifications, observe the following points:

- Make sure that the structural body strength of the vehicle is maintained
- Do not drill into enclosed frame structures
- Make sure the design of the body modifications or additional bodywork distributes the load evenly
- All metal edges must meet local regulatory standards for exterior and interior design. After cutting and drilling, the metal edges must be deburred and repainted
- All fasteners that pass through the floor, sides or roof must be protected against ingress of exhaust gases, moisture and corrosion
- Ensure that fasteners in the B-pillar area do not interfere with seat belts or automatic belt retractors

5.1.2 Add-on parts on the vehicle frame , wheel housing cover

Warning note

The entire wheel housing cover must comply with local approval regulations.

For integrated bodies such as ambulances or motor homes with raised rear overhangs built on the chassis, the following applies:

- Reduced ramp angles, e.g. due to rear entry step, should be discussed with the customer. Consider removable components to avoid damage on ferries or flat-bed trailers
- A special spare wheel storage may be required if it is obscured by the rear step, check for accessibility
- Minimum tyre to wing panel clearances for conversions are shown in the following figure and table:

Wheel housing dimensions

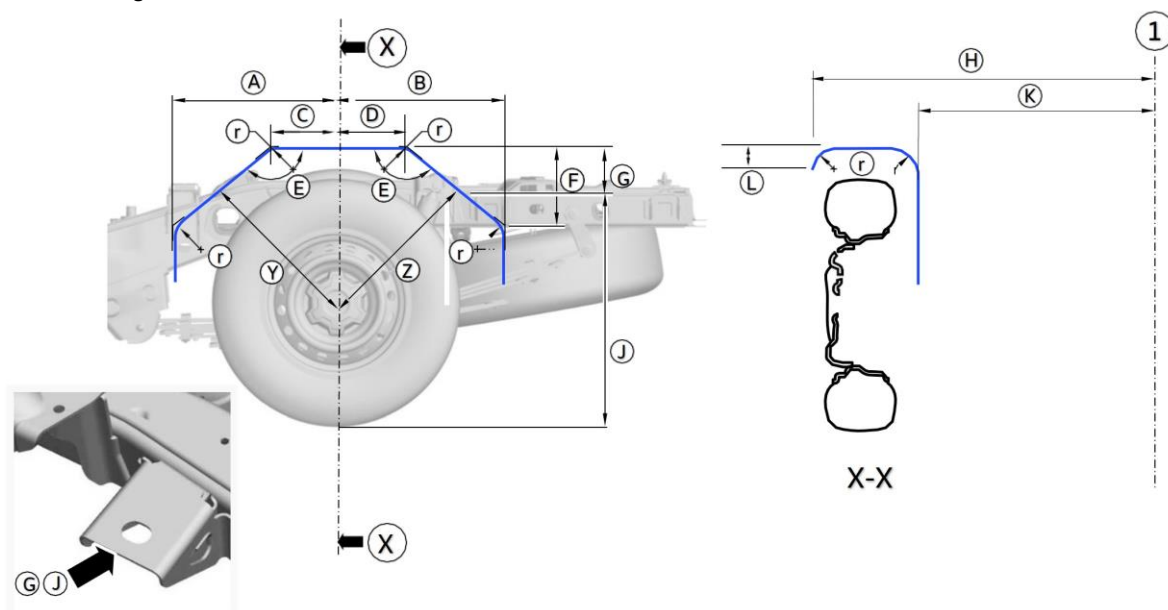

Practical note

The wheel housing dimensions show the minimum clearances required between the tyre and the body (wheel arch or wheel arch cover).

These clearances in the wheel housing were determined with the maximum permissible load, the largest wheel/tyre combination (see table below) and extreme driving manoeuvres. If the required clearances are not met, the converter must ensure that there is no contact between the tyres and the body in various driving situations.

Practical note

Changes in wheel and tyre sizes can affect the vehicle handling, certain functions of the driver assist systems and the vehicle characteristics.

Any modification must be made in accordance with local legal requirements. For further information, please contact your Volkswagen Commercial Vehicles partner or importer.

Information

- All dimensions are given in millimetres
- The dimensions Y and Z only apply if the dimension “J” corresponds to a value that is noted in the table below for the available wheels
- Dimension J is specified from ground level with the vehicle at kerb weight on level ground

Dimensions of the wheel guard				
Tyre specification	215/70R16	255/70R16	255/70R17 / 255/65R18 / 255/255/55R20	LT265/70R17
A	474	474	474	474
B	458	458	458	458
C	305 mm	305 mm	305 mm	305 mm
D	275 mm	275 mm	275 mm	275 mm
E	110°	110°	110°	110°
F	420	420	420	420
G	217	185	185	192
H	-	-	-	968
J	665	774	774	801
K	635	635	635	635
L	-	30	30	30
r	50 mm (max.)			
1	Centre line of the vehicle			
X	Section through centre of wheel guard			
Y	566	566	566	566
Z	525	525	525	525

5.1.3 Chassis frame

Warning note

- Do not cut, drill or weld any parts that are relevant to crash behaviour
- The converter must ensure that all modifications comply with general product safety requirements, legal provisions or type approvals
- Excessive heat may be generated by the exhaust system, especially the catalytic converter. Ensure that adequate heat protection devices are in place

Practical note

Uneven load distribution may result in unacceptable driving and braking behaviour.

When performing vehicle conversions/modifications, observe the following points:

- All mounting holes (see figure below) in the brackets on the top of the vehicle frame must be used to secure bodies
- Make sure that the structural strength of the vehicle is maintained
- Do not drill into enclosed frame structures
- Make sure that the design of vehicle modifications or the additional structure distribute loads evenly
- Metal edges must be repainted after cutting and drilling. All metal edges must meet local regulatory standards for exterior and interior protection
- All fasteners through the vehicle floor, sides or roof must be sealed. See also [chapter 5.4 "Corrosion protection"](#)
- Ensure that additional installations near the fuel tank will not damage the tank in the event of an accident

The following applies to all bodies that are attached to, or mounted on, the cab structure of the base vehicle:

- Care should be taken to ensure that neither the body nor the existing vehicle structure is distorted by the assembly process
- We recommend strengthening bonded joints by adding mechanical fasteners to prevent initial separation and long-term failure
- To avoid a point load on the frame, ensure that the screw connections are evenly distributed

Body mounting holes in chassis frame – double cab

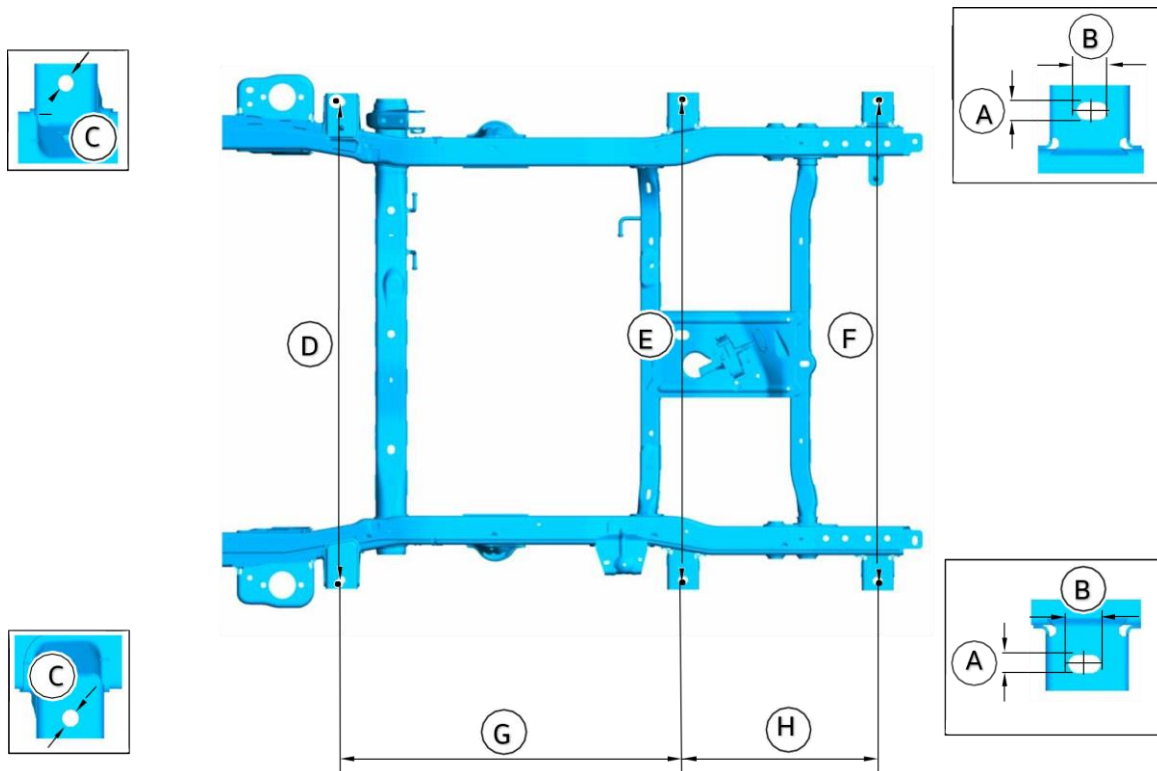

Dimensions (mm) for body mounting holes in chassis frame – double cab

Dimensions	
A	20
B	26
C	20
D	1244
E	1244
F	1248
G	890
H	506

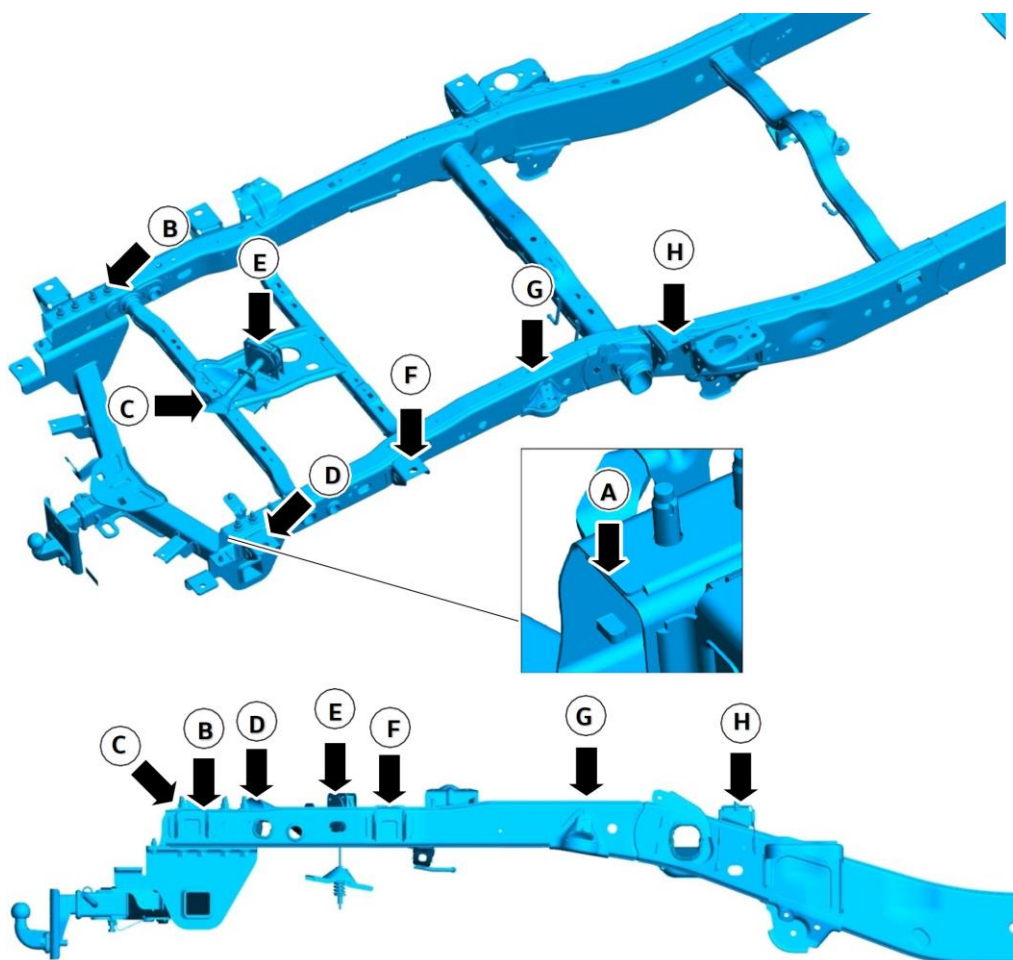

Vertical dimensions of body mounting holes – double cab

Measuring points	GVM @ RGAWR	MRO	WLTP	Height from A
A	540 * / 659 **	656 * / 776 **	637 * / 761 **	-
B – Towing bracket retaining bolts	-	-	-	37
C – Body bracket	-	-	-	6
D – Spare wheel winch guide cone	-	-	-	33
E – Spare wheel winch	-	-	-	44
F – Body bracket	-	-	-	12
G – Assembly support	-	-	-	22
H – Body bracket	-	-	-	12

*Only rear-wheel drive 110 kW EU4

**4x4 or 4x2

GVM = gross vehicle mass: total permitted weight

RGAWR = rear gross axle weight rating

MRO = mass in running order (tank 90% full / SCR tank 90% full + 75 kg driver)

Distance between body bracket/mounting support and centre of rear axle for all cab versions

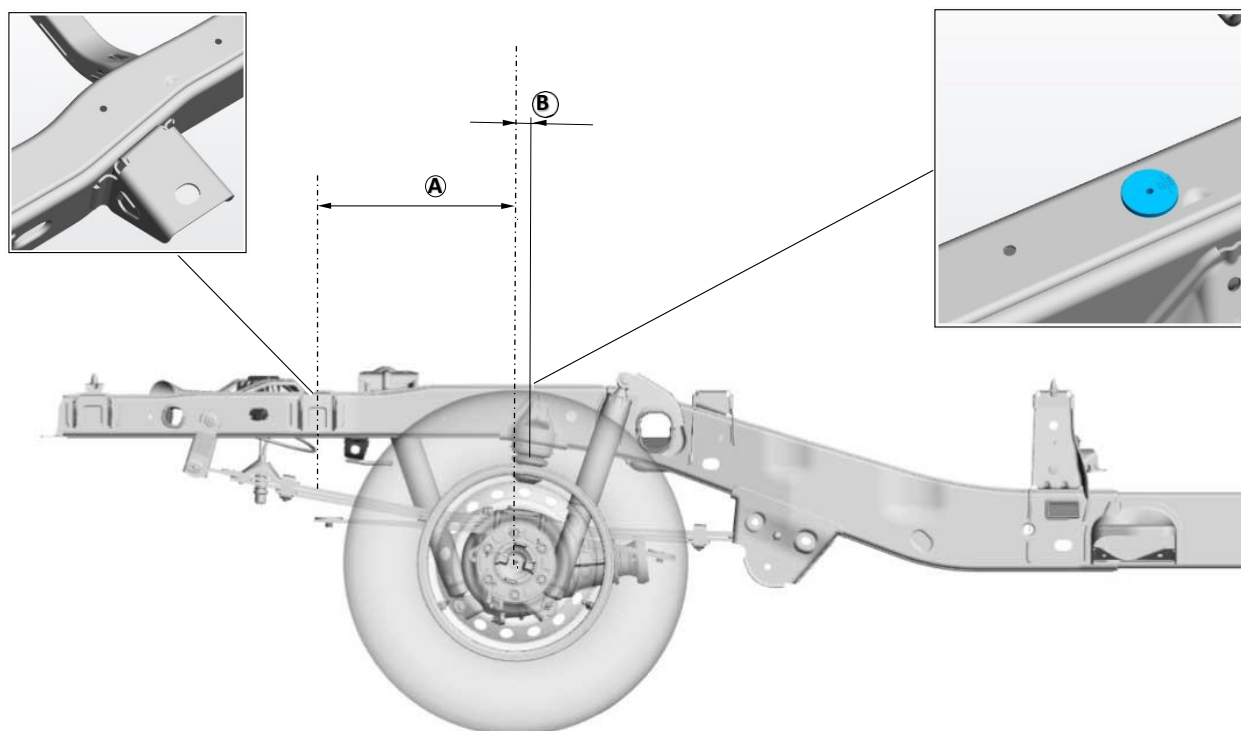

Dimensions	Measurement
A to the centre of the body bracket	446
B to the centre of the assembly support	23

5.1.4 Properties of the front section for cooling, collision, aerodynamics and lighting

Cooling

Continuous airflow through the front section and engine compartment must not be adversely affected by the installation of additional equipment. If in doubt, contact your Volkswagen Commercial Vehicles partner or importer.

Lighting

The lighting system must not be modified.

Collision

Do not cut, drill or weld any parts that are relevant to the crash behaviour in the event of a collision. Do not add any material in the crumple zone. This could adversely affect the calibration of the crash sensor.

The use of the side airbag system is not permitted if:

- A turning mechanism is attached to the front seats
- A partition, side cover or other attachments are mounted on the inner or outer area of the B-pillar or between the A and B-pillars and the B and C-pillars

Static and dynamic sealing and finishing

After cutting or drilling the body, ensure a proper seal against the ingress of water, salt, dust etc. Use sealing and surface material approved by Volkswagen Commercial Vehicles as well as underbody corrosion protection. See also [chapter 5.4 “Corrosion protection”](#).

5.1.5 Tipper bodies

Double cab versions can be used for tipper conversions with the exception of the extended rear chassis frame.

All versions allow one-way and three-way tipping.

We recommend that the tipping system only be in operation when the engine is running. We also recommend that the main switch be located in the safety area of the cab. Ensure that the gross axle weight rating, including the minimum load on the front axle, is not exceeded or fallen below.

For tipper subframes, follow these guidelines:

- Design a full length continuous frame for the entire length of the vehicle frame with fasteners for engine, pump unit, tank, pivot points and cylinders
- Use all the mounting points on the chassis frame to fit the subframe
- Very rigid subframes can damage the chassis frame by preventing its elastic deformation. Flexible mounts should therefore be used with an elasticity of up to +/- 12 mm when the vehicle is loaded or unladen (whichever is the worst case). These compliant mounts should have a minimum deflection of 2 mm per 200 kg mass at each **front** chassis frame mount. The fasteners must be designed such that the screw connections are captive. Use at least two M10 size and grade 8.8 and higher bolts with washers and self-locking nuts at each rigid and flexible chassis frame position
- The subframe must extend to the rear of the cab and be secured at all mounting points, with the front end designed to minimise localised frame loading. However, it is preferable to fit the subframe on the mounting brackets at a distance from the top of the chassis frame
- Lateral tipping loads/forces must be absorbed by the subframe. We do not recommend applying loads to the chassis frame

5.1.6 Tank and bulk container superstructure

Due to the high rigidity of tanks, it is necessary to mechanically decouple the tank and its subframe from the chassis frame to allow for elastic deformation of the chassis frame.

Please observe the following guidelines:

- Secure the tank to the full length of the subframe
- Secure the subframe to all mounting points on the chassis frame
- The front mounting points must be designed so that they allow relative movement between the chassis frame and subframe
- The subframe must extend to the rear of the cab and must not come into contact with the chassis frame at the end, even under the greatest deflection.
- Flexible mounts should be used with an elasticity of up to +/- 12 mm when the vehicle is loaded or unladen (whichever is the worst case). These compliant mounts should have a minimum deflection of 2 mm per 200 kg mass at each **front** chassis frame mount. The fasteners must be designed such that the screw connections are captive. Use at least two M10 size and grade 8.8 and higher bolts with washers and self-locking nuts at each rigid and flexible chassis frame position

5.1.7 Aerial cable routing

Information

- The manufacturer's instructions and installation guidelines shall be observed.
- Aerial cables should be routed from the engine compartment through the existing grommet and into the vehicle interior. Make sure that no water can enter the interior
- Cables shall be kept as short as possible, shall be entwined and shall be shielded (coaxial cable)
- Abrasive areas must be avoided.
- Ensure good earth connections to body (aerial and device)
- For information on the main beam headlight cable routing, see [chapter 4.6 "Exterior lighting"](#) – Additional exterior lighting

Warning note

- Ensure that the aerial cables have adequate clearance from hot and moving parts
- Do not secure the aerial cables to the original vehicle wiring, fuel lines, and brake lines
- Keep the aerial and power cables at least 100 mm away from electronic modules and airbags and associated wiring

5.1.8 Roof loads and roof carriers

Roof carriers can be fitted to all double cab versions provided that the following conditions are met:

- The supported load must not exceed 85 kg
- The height of the load must not exceed 300 mm
- The load must be evenly distributed
- For information on suitable genuine part carrier systems and their fastenings on the vehicle, please contact your local Volkswagen Commercial Vehicles partner or importer
- Removing or obscuring the radio aerial rod (particularly by metal objects) will impair the radio's reception performance
- Obscuring the aerial base (especially by metal objects) impairs GPS performance

Double cab

The above limitations are based on the strength of the body structure, vehicle handling, brakes, and axle loads. These instructions also apply to applications on the double cab, in particular for the steering, brakes and front axle, as well as for the additional permanent loads in the area of the A-pillar. This total additional load should not exceed 60 kg.

Roof loads raise the centre of gravity of the vehicle and lead to a high dynamic axle load shift. Also, there is greater body lean when driving on rough roads and when cornering. The vehicle handling is significantly impaired.

When loading the roof carrier, we recommend distributing the load evenly and keeping the centre of gravity low. Loaded vehicles with a higher centre of gravity react differently to unladen vehicles. Take particular care when driving a heavily loaded vehicle.

Make sure that the loaded vehicle is only operated up to the maximum permissible centre of gravity height. For more information, please refer to your Owner's Manual or contact your Volkswagen Commercial Vehicles partner or importer.

Roof carrier – special installation for vehicle conversion

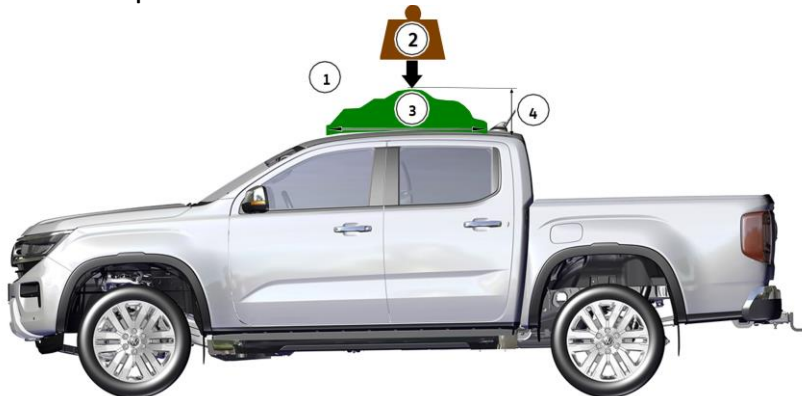

Item	Description
1	Rear edge of the front mounting point
2	Maximum 85 kg (dynamic) / maximum 350 kg (static)
3	Maximum roof carrier length: within the length of the water drain gutter
4	Maximum loading height 300 mm

5.1.9 Add-on parts on the cargo box

Warning note

Use only the recommended mounting points, otherwise the cargo box may be damaged.

Practical note

- Forces acting on the cargo box due to bodies and loads must be applied via the recommended structural mounting points
- A minimum clearance of 28 mm must be maintained between the cab and any mounted bodywork, load bearing raised accessories, the roof, cargo box or load management structure to prevent damage to the cab structure during operation

Vehicles fitted with a cargo box are equipped with mounting locations in the cargo box side rail that allow for the installation of body solutions such as hardtops, covers, sport bars, luggage racks etc.

Information

- Side rail mounting points with M8 threaded fasteners must not be tightened to a torque greater than 25 Nm
- For information on the factory load securing, refer to the Owner's Manual for the vehicle

See [chapter 1.11 "Assemblies and ergonomics"](#).

Cargo box reinforcing bracket

Practical note

- Make sure all loads are properly balanced and secured
- Cargo box reinforcing brackets must be installed for accessories that extend beyond the cargo box side rail and weigh more than 45 kg

Practical note

- To support the structural strength of the cargo box when accessories are fitted, Volkswagen Commercial Vehicles recommends installing cargo box reinforcing brackets
- Examples include hardtops, ladder racks, luggage rack cross members, load-bearing raised accessories etc. Cargo box reinforcing brackets are available from the *ETKA system as Volkswagen Genuine Accessories

* ETKA: electronic parts catalogue for after sales

These reinforcing brackets are designed to provide additional reinforcement between the floor and the wall of the cargo box to ensure that the off-road capability of the cargo box is maintained when higher load bearing accessories are installed.

Information

For vehicles produced before 25 November 2024, it may be necessary to assemble reinforcing brackets. See the factual information above. The assembly must then be carried out as shown in "Picture A". Assembly instructions are included in the kit.

For vehicles produced from 25 November 2024 onwards, the reinforcing brackets are assembled ex works as standard. The reinforcements are then assembled as shown in "Picture B".

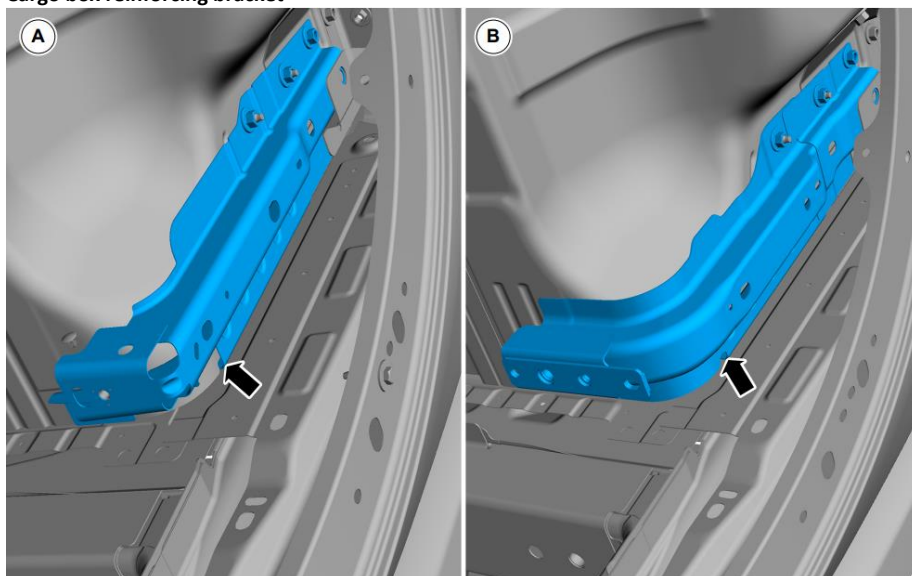
Cargo box reinforcing bracket

Picture	Description
A	View of cargo box reinforcing bracket after assembly as a retrofit package.
B	View of cargo box reinforcing bracket already fitted as standard ex works.

Practical note

Please check on the delivered vehicle whether the cargo box is already equipped with the necessary reinforcements ex works, or whether a retrofit is required. Refer to the illustrations above.

Position of the reinforcing brackets on the cargo box

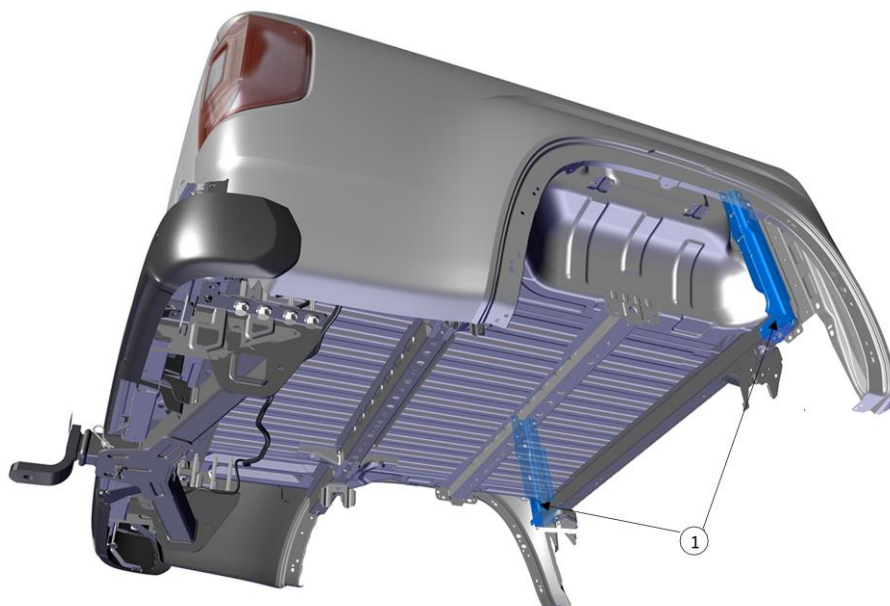

Element	Description
1	Cargo box reinforcing bracket

Information

Volkswagen Commercial Vehicles provides these cargo box reinforcing brackets as a kit with assembly instructions as an original accessory part via the electronic parts catalogue (ETKA) under part number 2HJ 071 776C. Please contact your Volkswagen Commercial Vehicles partner or importer.

Practical note

These reinforcing brackets have been specially developed as licensed Genuine Accessories. Their suitability for use with accessories from other manufacturers (which are not licensed by Volkswagen Commercial Vehicles) must be checked by the manufacturer or the supplier of the accessories.

Said party bears responsibility for the proper use of these reinforcing brackets in a vehicle modified by a converter or modified using products from another accessory manufacturer.

It is the responsibility of the vehicle converter to ensure that the conversion is performed in a manner that will ensure the durability of the cargo box.

Contact your Volkswagen Commercial Vehicles partner or importer for information on supplying and installing the reinforcement brackets.

Cover, ladder rack, canoe rack

Practical note

If a cover, ladder rack, canoe rack or similar accessory mounted on the cargo box is attached, a combination of the mounting points indicated on the top of the cargo box must be used to ensure proper attachment to the vehicle. Load-bearing and heavy vehicle accessories must also be secured in the transverse plane to ensure a secure fit.

Practical note

The upper plastic cover of the cargo box (edge cover of the box) is not designed for a greater load. Do not create a punctiform clamp connection directly on these surfaces.

To ensure safe assembly for load-bearing and heavy vehicle accessories, the stable mounting points in the cargo box must be used.

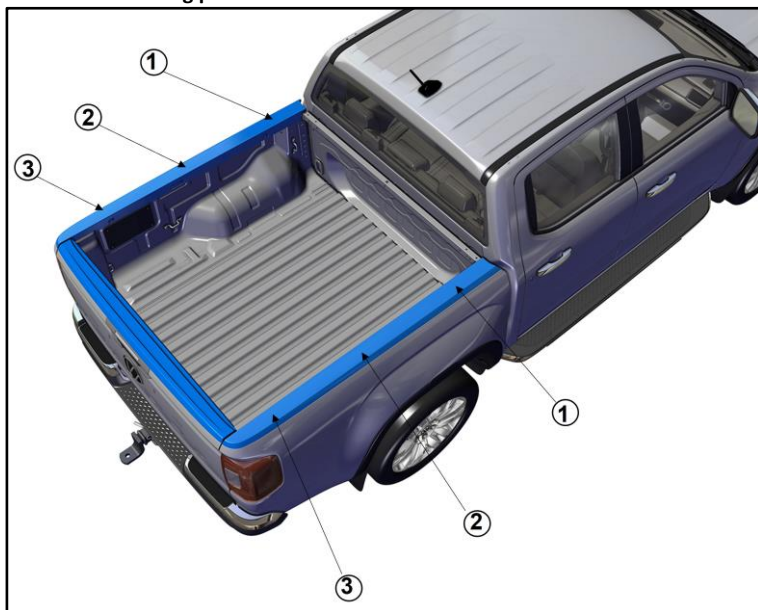
Structural mounting points – double cab

Item	Description
1	Front M8 structural mounting points
2	Central M8 structural mounting points
3	Rear M8 structural mounting points

Mounting points for side rails

Element	Description
1	Left load mounting-rail
2	Right load mounting-rail

Some vehicles are equipped with side mounting rails that have multiple pre-threaded mounting points. Additional load carrying capacities and fastening devices are described in the owner's manual for the vehicle.

Load-carrying capacity of the mounting points

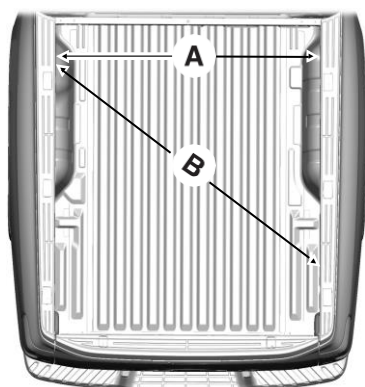

A	B
The maximum force between directly opposite mounting points is 125 kg	The maximum force between diagonally opposite mounting points is 272 kg

Sport bar

Information

When fitting a sport bar, a combination of the specified mounting points must be used to ensure suitable attachment to the vehicle.

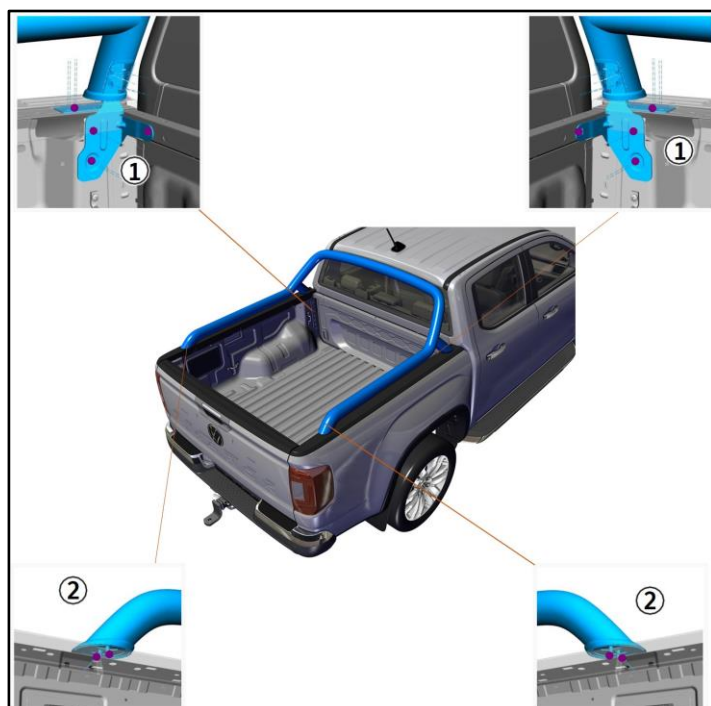

Item	Description
1	Front M8 structural mounting points
2	Rear M8 structural mounting points

5.1.10 Front wing trim

Information

View of right wing trim, similar on left.

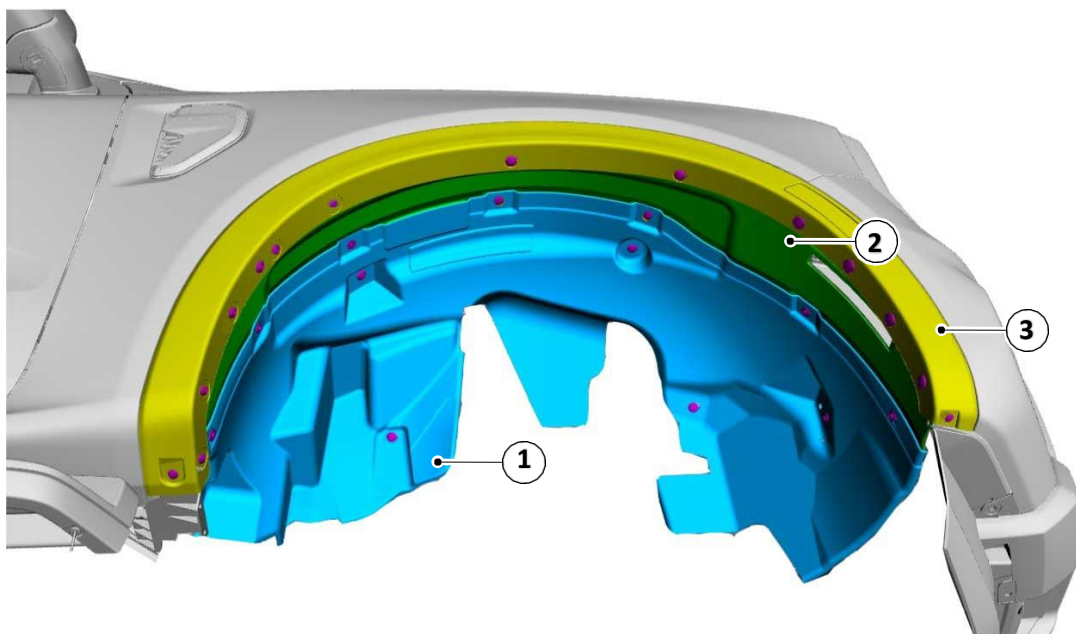

Item	Description
1	Wing trim
2	Front inner wheel housing trim
3	Trim strip – wheel cut-out

To allow access to the engine compartment and certain accessory attachments, the front right and left wing trims (1) can be removed without removing the wheel housing trim and front wing mud guard.

The wheel cut-out trim strip can be removed after the wing trim is removed by accessing and releasing the brackets for the wheel cut-out trim strips from the inside of the wing panel.

Refer to the Workshop Manual or contact your Volkswagen Commercial Vehicles partner or importer for information on the correct removal and installation procedure to assist in the removal of the wheel housing trims.

5.2 Airbag systems

5.2.1 Airbags

Front seats

- Side airbags are not compatible with swivelling front seats
- If you wish to retrofit a turning mechanism on the front seats and/or an armrest on the outside of the front seats, please note the function and/or deployment zone of the side airbag
- Pressure-based airbag sensors for the side airbags are located near the centre of the interior door panel at the top of the front doors on all cab versions
- Acceleration-based airbag sensors for the side airbags are located on the inside of the C-pillar near the underside of all cab versions
- For double cab vehicles, additional airbag sensors for acceleration-based airbags are located on the lower B-pillar directly above the automatic belt retractor

Warning note

Modifications or reinforcements in the area of the sensors can affect the function of the side airbags and lead to uncontrolled deployment of the side airbags.

Please note that this does not apply to vehicles equipped with only front airbags and not side airbags. Drilling and grinding work in this area is only permitted when the battery is disconnected.

Deployment zones of the driver and front passenger front airbags

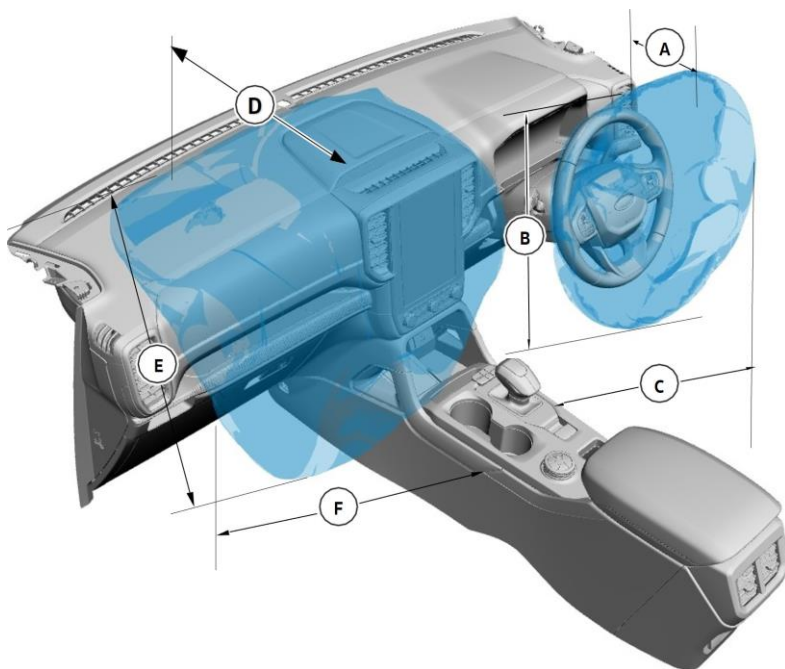

Dimensions (mm)			
A	268	E*	550
B	530	E**	521
C	525	F*	600
D*	630	F**	527
D**	592	-	-

*120 l single-stage passenger airbag (Australia, Europe, New Zealand)

**90 l single-stage passenger airbag (except Australia, Europe, New Zealand)

Deployment zones of the driver and front passenger knee airbags

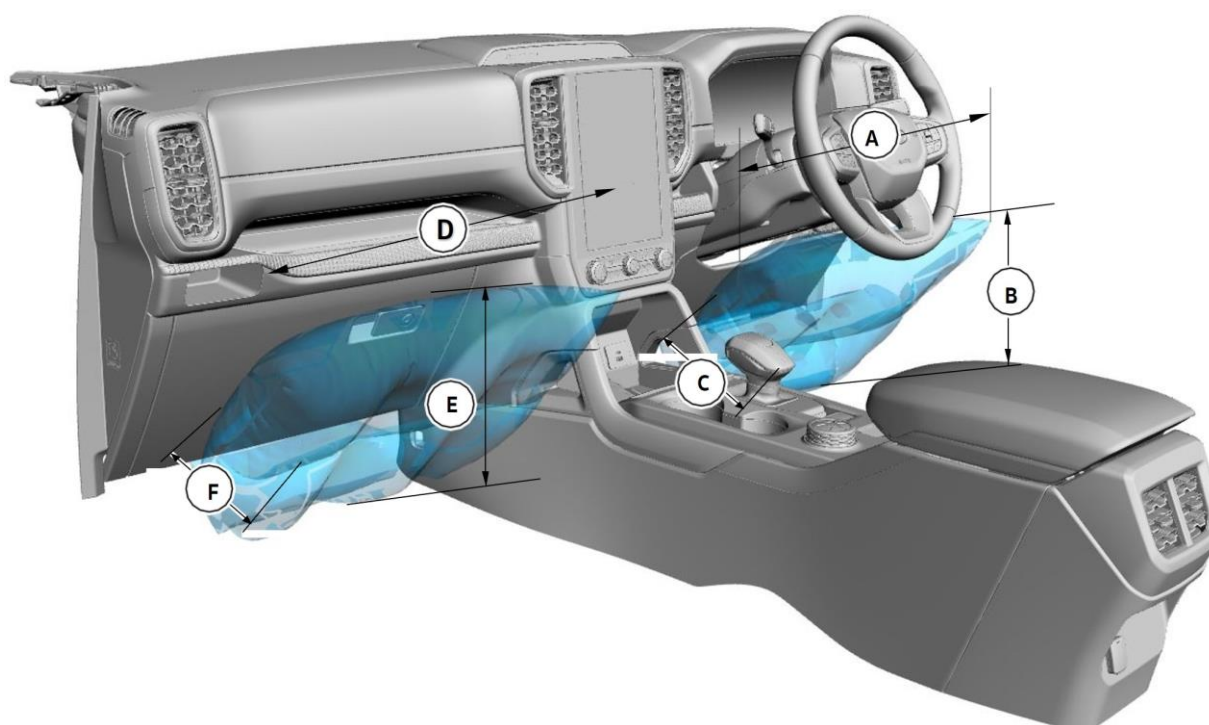

Dimensions (mm)			
A	540	D	540
B	400	E	400
C	170	F	170

Warning note

- Do not position any objects or assembly materials on the airbag cover, on the side of the seat backrests (of the front seats) or in areas of the front seats that could come into contact with an airbag that deploys. Non-compliance with these instructions can increase the risk of injury in the event of an accident

Deployment zones of the central airbag

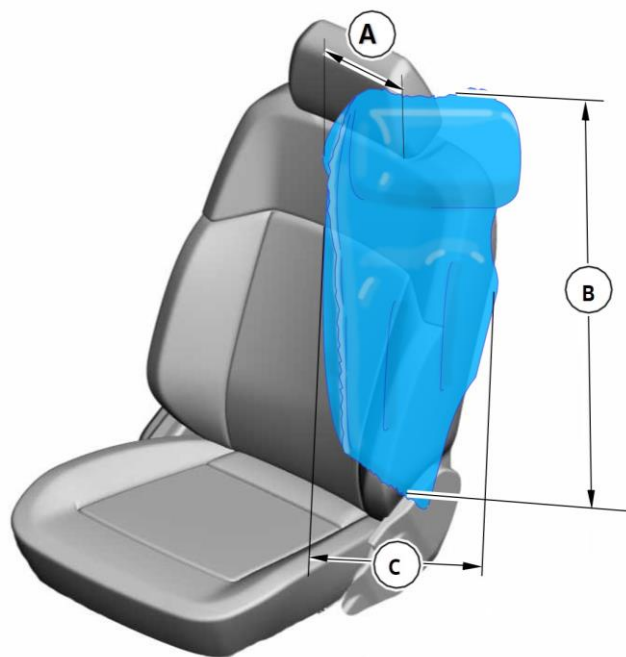

A	350
B	750
C	450

Information

Left shown here, right is similar

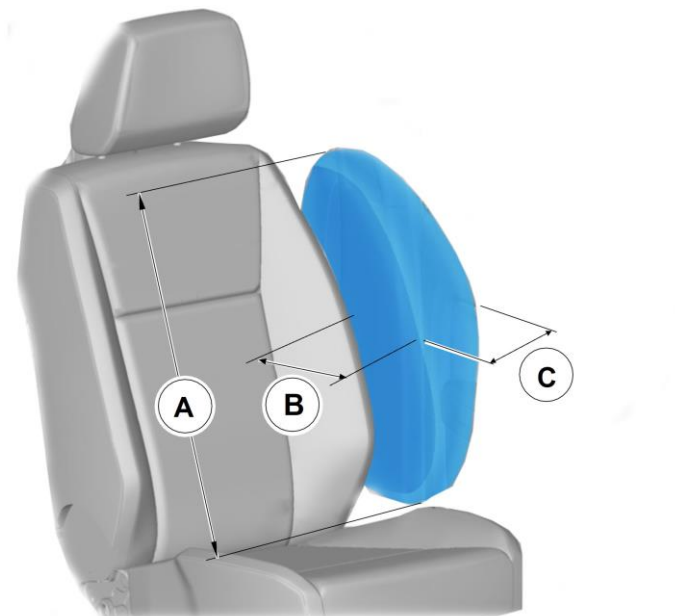
Deployment zone of the side airbag

Dimensions (mm)	
A	550
B	350
C	250

Information

Left shown here, right is similar

Deployment zones of curtain airbag – double cab



Dimensions (mm)			
A	140	C	250
B	40	D	100

Information

Left shown here, right is similar

5.2.2 Additional impact sensors (front)

Warning note

- Modifications or reinforcements in the area of the front additional impact sensors may adversely affect their function.
- Modifications or additions to the front section of your vehicle (including the bonnet, bumper carrier system, frame, front section body structure, towing hook and bonnet pins) may affect the function of the airbag system and increase the risk of injury. Do not make any modifications to the front section of your vehicle or add any additional parts



Item	Description
1	Front impact sensors

5.3 Seat belt systems

Warning note

Follow the seat belt system removal and installation procedures approved by Volkswagen Commercial Vehicles in order to ensure proper operation of the restraint system.

Removal and reinstallation of the seat belt, automatic belt retractor, or any component of the seat belt system should be avoided. If, however, it is necessary to remove and reinstall the system during the conversion, follow the seat belt system removal and installation guidelines as described in the Workshop Manual. Contact your Volkswagen Commercial Vehicles partner or importer for further information.

When removing the seat belt system, a belt fork retainer should be applied to the belt webbing 200 mm below the tongue stop. This will prevent a situation where all the belt webbing runs back into the automatic belt retractor and the retractor is locked.

When reinstalling the automatic belt retractor, first attach the retractor to the vehicle and carefully pull the belt webbing out of the retractor to allow the D-loop to be fitted. Then remove the fork retainer. Once the automatic belt retractor is locked in place, allow a small amount of belt webbing to roll back into the retractor so that the belt webbing lock can release. Do not attempt to release the automatic belt retractor by pulling on the webbing with significant force or by manually disturbing the locking mechanism.

5.3.1 Seat belts – permitted drilling zones

DoubleCab – first row seat belt

Warning note

- Do not drill in the area of the automatic belt retractors on the right/left side
- Drilling is only permitted in the areas marked in red
- Damage to automatic belt retractor: when drilling holes near or above the retractor and anchorage pretensioner, the mechanisms must be covered to prevent swarf/debris from falling into the assembly group and causing functional problems.
- Damage to the belt webbing: all installed parts must not cut, pinch, or interfere with the belt webbing along its entire path (from the automatic belt retractor to the D-ring). Avoid sharp-edges near the belt webbing; all edges must have a minimum radius of 0.5 mm. Avoid installing parts that can change the course of the belt to the occupant

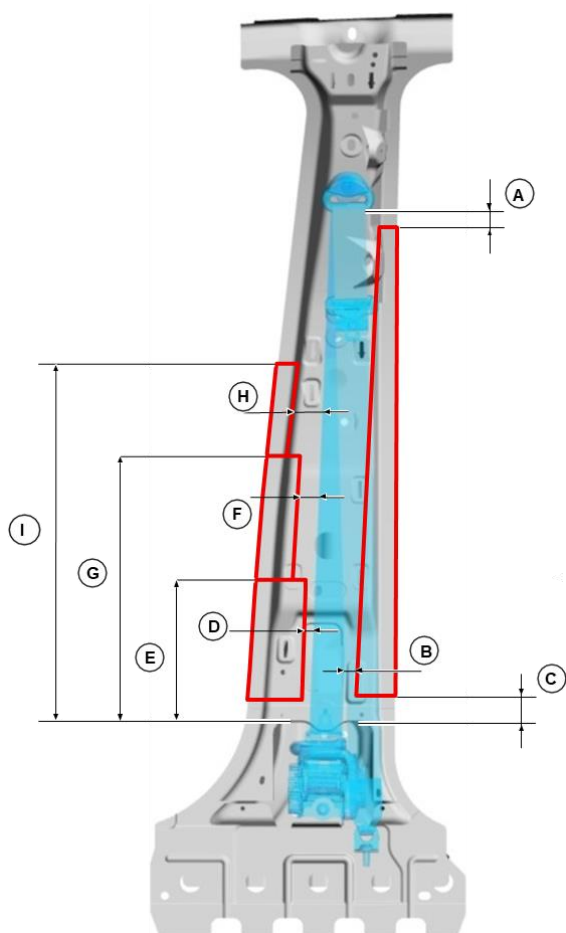

Fig.: Right-hand seat belt (schematic diagram), left-hand side in mirror image

Dimension	-
A	30 mm below the bottom of the D-ring
B	15 mm to the right of the belt webbing
C	30 mm above the hole for the automatic belt retractor
D	25 mm to the left of the belt webbing
E	220 mm above the hole for the automatic belt retractor
F	35 mm to the left of the belt webbing
G	380 mm above the hole for the automatic belt retractor
H	50 mm to the left of the belt webbing
I	525 mm above the hole for the automatic belt retractor

5.4 Corrosion protection

5.4.1 General information

Avoid drilling into enclosed frame vehicle parts to avoid the risk of corrosion from chips.

However, if holes are required, note the following:

- After cutting or drilling, the metal edges must be carefully deburred before repainting
- The unprotected metal edges must be repainted to protect them from corrosion
- Attempt to remove all chips from inside the side support to prevent corrosion
- Apply suitable and approved corrosion protection inside and outside the chassis frame if the coating has been damaged by drilling or welding
- In regions where salt is used to de-ice road surfaces, it is necessary to reapply cavity wax to the inner frame section that was damaged by drilling or welding

5.4.2 Touching up damaged paintwork

After cutting or reworking sheet metal on the vehicle, the damaged paint must be touched up/repaired.

Ensure that all materials are compatible with the relevant Volkswagen specifications, and try to maintain the original condition as far as possible.

Warning note

Surfaces of components such as brakes or catalytic converters must not be painted over or contaminated.

5.4.3 Underseal and materials

Make sure that all materials used comply with Volkswagen specifications and try to maintain the original condition as far as possible. Some manufacturer-specific products will affect the original finish.

The specifications for corrosion protection materials can be obtained from your Volkswagen Commercial Vehicles partner or importer.

5.4.4 Painting rims

Warning note

Do not paint any surfaces that are in contact with wheels, brake drums or brake discs, hubs and holes or surfaces under wheel nuts. Any further treatment in these areas may adversely affect the wheel fit and thus the safety of the vehicle. Carefully cover the entire wheel when painting the body.

5.4.5 Galvanic (bi-metallic) corrosion / contact corrosion

If materials with different electrochemical potential come into contact with each other, take appropriate measures to prevent electrical contact by using an insulating material.

5.5 Frame and body mounting

5.5.1 Mounting points and pipes

Warning note

Drilling into reinforcements and components that are relevant to strength may adversely affect crash behaviour. The converter must ensure that all modifications comply with general product safety requirements, regulatory provisions or type approvals.

Unused holes on the frame may be a result of the manufacturing process and are not necessarily designed for mounting additional equipment/materials. Always use housing mounts as shown in the subframe for low-floor or other equipment. If additional fasteners are required, please follow the recommendation in the figure shown. This does not apply to areas where loads occur, such as fasteners on springs or shock absorbers.

Information

After drilling, deburr and countersink all holes and remove chips from the frame. Follow corrosion protection procedures.

See also chapter 5.4 “Corrosion protection”.

Drilling and welding of frames

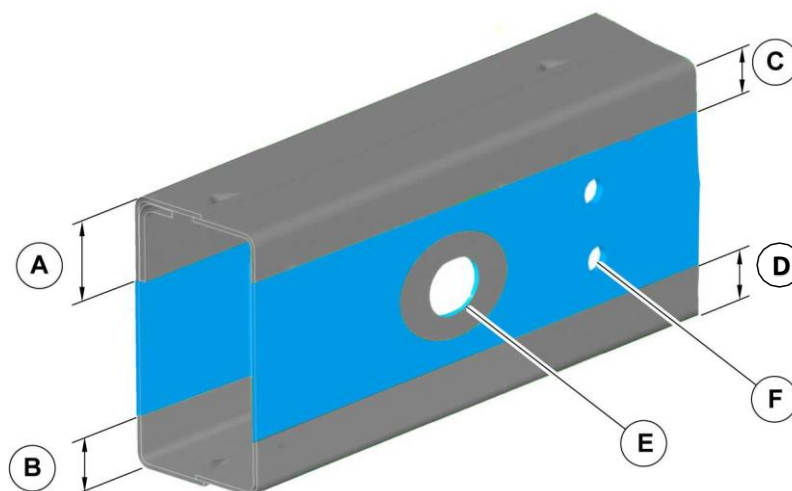

Dimensions (mm) for body mounting holes in the upper flange of the chassis frame (see table below).

Item	Description
A	45 mm FRONT / 15 mm REAR
B	45 mm FRONT / 15 mm REAR
C	45 mm FRONT / 15 mm REAR
D	45 mm FRONT / 15 mm REAR
E	Do not enlarge the holes in the frame sections and do not drill in the surrounding areas.
F	Do not drill more than two vertical holes in the frame sections.

Welding on the chassis frame is only permitted as described below:

- No gas flame may be used to create holes in the frame. Only use sharp drills to drill holes
- Cold riveting is only to be used if mounts are to be fastened with rivets
- Use only high-strength bolts and appropriate nuts for bolted attachments

Bolt specifications:

- Metric – property class 8.8 or 10.9
- Japanese – 7T or 9T
- SAE – class 5 or 8

- To ensure that screws or rivets fit well, the holes must be deburred after drilling. To improve screw seating, a chamfer of 1.0 mm x 45 degrees must be applied to the screw head side of the hole
- Do not drill holes near changes to the longitudinal member profile
- Do not drill out existing holes in top and bottom flanges
- No more than two holes may be drilled in a vertical line from the frame stay down
- Suitable corrosion protection shall be applied after drilling work on the vehicle. Corrosion protection and protective coatings for all modifications must conform to all local regulations.
- To avoid excessive load concentrations, the vehicle structure must be provided with reinforcements in the area of holes that are larger than 16.5 mm
- Reference holes/reference edges must not be drilled or changed
- Do not drill new or modified holes larger than 16.5 mm

[See also chapter 5.1 “Body”.](#)

5.5.2 Removing rear seats

Information

If the rear seat is to be permanently removed during the conversion, the rear seat mounting positions in the floor must be covered to prevent noise, dirt and water ingress.

Mounting positions for rear seats

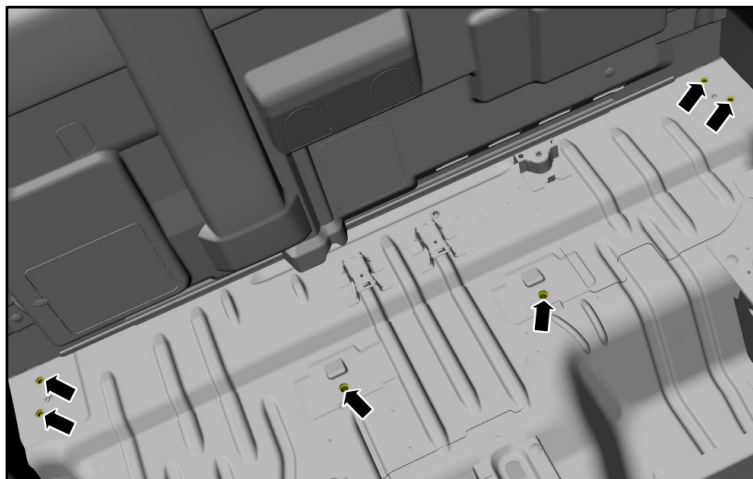

5.5.3 Self-supporting body structure

Bodies and structures can be evaluated as self-supporting if they meet the following conditions:

- Cross members are used at each mounting point on the chassis (see figure below)
- Each cross member has an appropriately designed connection to the body side panel (3) or continuous floor frame (5), see illustration
- The body side panel or continuous floor frame supports any overhang beyond the chassis frame, whether it is a standard frame or an extended frame
- Alternatively, the self-supporting body structure can be designed as shown in the figure
- This concept is based on a self-supporting body with the floor mounted directly on top of the chassis frame
- The figure shows a general vehicle cross-section in which the cross members and opposite booms are flush with the surface of the chassis frame longitudinal members
- It is important to the overall function of the vehicle structure that the booms are each connected to a continuous longitudinal floor side frame or structural body side structure assembly

Low-floor rework only as a guideline:

- Design individual cross members and booms to be spaced no more than 600 mm apart
 - The boom moment must be absorbed by a cross member between the chassis frame with shared through bolts where possible
 - Drill the frame and add spacer tubes
- [See chapter 5.5](#)
- The outer ends of the boom should be attached to the supporting body side/floor edge frame or body side structure (including in the wheel housing area)
 - The wheel housing should be fastened continuously in the longitudinal direction by means of a rigid attachment to the floor edge frame or body side structure.
 - Floor plates should be firmly attached to cross members and supporting booms, but not to the top of the chassis frame
 - Attach heat shields to the lower floor near the exhaust system

Typical design principles for a self-supporting body structure

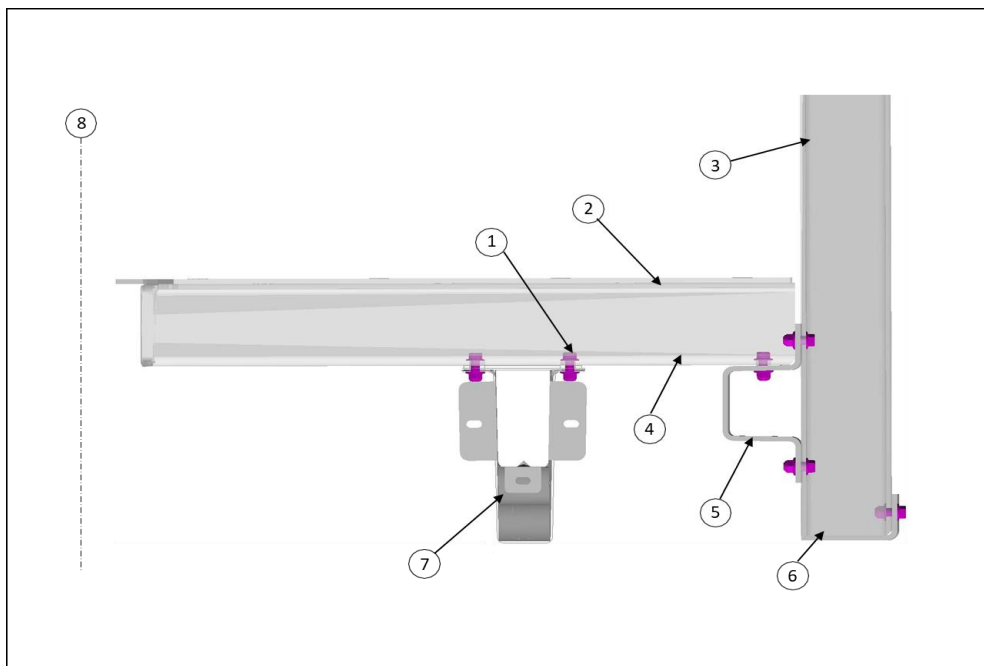

Item	Description
1	Secure with 2 x M10 bolts at all standard positions
2	Floor panel
3	Body side frame
4	Floor cross member
5	Continuous U-section floor frame
6	L-section longitudinal member
7	Frame longitudinal member of the base vehicle
8	Vehicle centre line of the base vehicle

See also chapter 5.1 "Body".

5.5.4 Frame drilling and tube reinforcement

The chassis frame can be drilled and reinforcement spacer tubes can be welded on, provided the following is observed:

- All details shown in the illustration (see figure in chapter 5.5.3) must be observed
- Drill and weld only the side panels of the chassis frame
- Drill the holes very precisely and use a drilling template with drill guide to ensure the holes are perpendicular to the vertical centre line of the frame (note: consider the lifting angle of the longitudinal member)
- Drill with a smaller diameter-and then ream the holes to the correct size
- Remove all chips from the inside of the longitudinal member and treat it to prevent corrosion
- Fully weld each end of the tube and grind flat and square, in groups if necessary. Pay attention to the lifting angle of the longitudinal member
- Apply corrosion protection to the inside and outside of the chassis frame

- Holes should be placed in groups of two (2) either vertically at a distance of 30 to 35 mm from the top and/or bottom of the chassis frame or horizontally at a minimum distance of 50 mm, 30 to 35 mm from the top and/or bottom of the chassis frame
- Always use M10 bolts with a-grade of 8.8 or higher
- Do not position the tubes at mid chassis frame height as this may affect the buckling strength of the lower side panels
- If possible, the bending moments-at the booms should be absorbed by suitable inner cross members, in a row between the chassis longitudinal members
- A diameter of 16.5 mm is the maximum hole diameter allowed in the chassis frame side panel, regardless of use
- Avoid drilling into enclosed frame members to prevent the risk of corrosion from chips.
Refer to: [chapter 5.4 “Corrosion protection”](#).

5.5.5 Additional equipment – subframe attachment

The following guidelines should be observed for typical subframes and longitudinal members for flat bed, low-floor and platform vehicles or attachments that exceed the standard frame length:

- Platform and low bodies mounted on integral longitudinal members (metal members or box sections – not wood) must use all brackets of the chassis frame
- Longitudinal members of the body must be relieved at the front end if they are to come into contact with the top of the chassis frame, in order to minimise stress concentrations. However, it is preferable to fit the longitudinal members of the body on the brackets of the chassis frame at a distance to the top of the chassis frame
- At least one M12 screw of property class 8.8 must be used for each mounting point
- For chassis with minimum ground height, ensure that there is sufficient clearance between the rear wheels in the wheel housings. See also [chapter 5.1.2. “Add-on parts on the vehicle frame , wheel housing cover”](#). The corresponding wheel suspension values can be found in the vehicle data sheets

5.5.6 Area for fitting additional body attachments to the rear of the bumper

Practical note

The measurements should be taken from the bumper edge to the rear of the vehicle, with the vehicle standing on level ground.

- The area intended for fitting add-on parts is defined as 220 mm horizontally and 95 mm vertically downward to the road surface, with a maximum width of 1,390 mm around the vehicle centre line
- The manufacturer does not recommend attaching additional add-on parts (ball couplings, steps, bicycle carriers and luggage carriers) outside the designated area

5.5.7 Water tank on camping vehicles

Information

We recommend attaching a sticker or label near the filler opening indicating the fluid to be used, e.g.: “Water only” for water tanks.

5.5.8 Conversions with an extended wheelbase

Warning note

- All extended wheelbase conversions must comply with the frame and assembly guidelines referenced in this publication
- All vehicles with frame extensions must comply with local regulations for emissions, durability and conformity

Practical note

- All emission control systems must remain operational and fully functional after wheelbase extension

Contact your local Volkswagen Commercial Vehicles partner or importer for further information.

Modification to the fuel system for conversions with an extended wheelbase

Warning note

- All modifications to the fuel system must comply with the regulations in force in the country of registration
- All modifications to fuel system components, such as extending or re-routing fuel lines and relocating fuel system components, must be approved by a local regulatory agency

Exhaust system modifications for conversions with an extended wheelbase

Warning note

- All modifications to the exhaust system must comply with the regulations in force in the country of registration
- Bodies and load carriers intended to accommodate or transport humans or live animals must be manufactured and installed so that the outlet of the exhaust system is positioned to discharge exhaust gases to the outside and away from the sealed passenger compartment
- Any modification or additional body structure that affects the exhaust system must not block or obstruct the exhaust gas stream

Practical note

- Acoustic/silencing devices located in the permitted modification zone may be relocated, but not removed, and may require approval testing by regulatory agencies to ensure compliance with applicable noise regulations
- Use existing mounts for the modified exhaust system whenever possible

Information

- Modifications to the emission control system as part of the exhaust gas treatment (selective catalytic reduction system) are not permitted except in the areas specified below
- Modifications to the exhaust system to support conversions with an extended wheelbase are limited to the sections shown in the following figures:

2.0 | Single Turbo Diesel Euro 6d

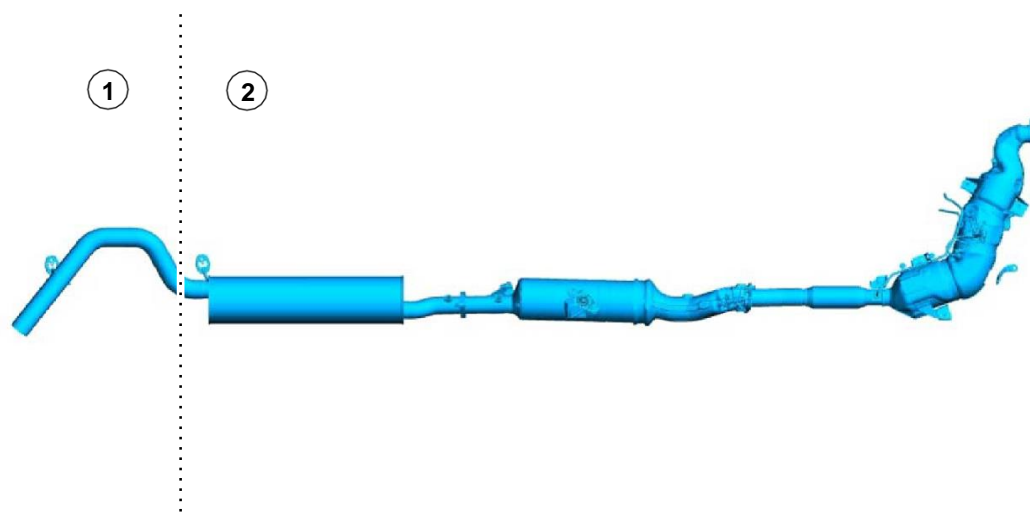

Position	Description
1	"Modification permitted" area
2	"Modification not permitted" area

2.0 | Bi-Turbo Diesel Euro 6d

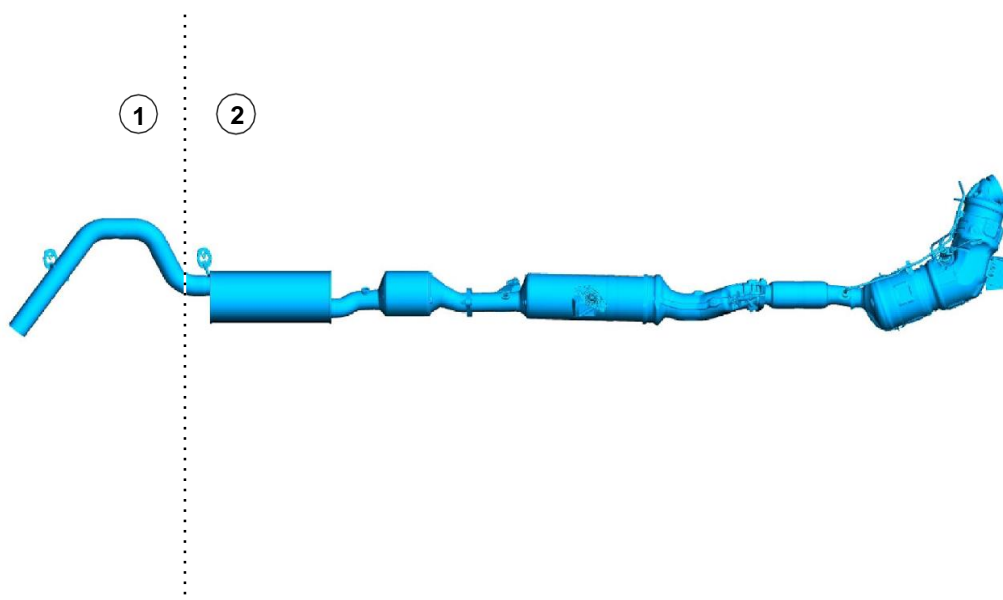

Position	Description
1	"Modification permitted" area
2	"Modification not permitted" area

3.0 | Turbo Diesel Euro 6d

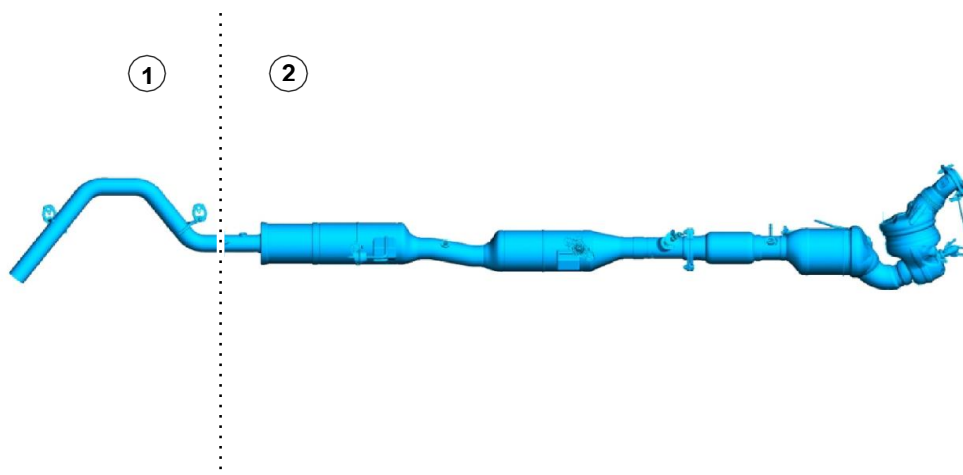

Position	Description
1	“Modification permitted” area
2	“Modification not permitted” area

Selective catalytic reduction systems for conversions with an extended wheelbase

Warning note

- All modifications to the selective catalytic reduction system must comply with the regulations in force in the country of registration
- All modifications to components of the selective catalytic reduction system, such as extending or re-routing pressure lines and relocating system components, must be approved by a local regulatory agency

Contact your local Volkswagen Commercial Vehicles partner or importer for further information.

6 Technical data

6.1 Build dimension drawings

Please refer to our build dimension drawings for the dimensions of the Amarok.

They are available for download in DXF, TIFF and PDF format at the CustomizedSolution Portal (CSP) of Volkswagen AG. All files (except PDFs) are packed as Zip archives. The files can be unpacked using Winzip (PC) or Ziplt (MAC).

Information

Current build dimension drawings are available for downloading from the CustomizedSolution Portal (CSP) of Volkswagen AG under the “Technical drawings” menu item.

6.2 Diagrams (foil templates)

Vehicle views of the Amarok in 1:20 scale are available for download in TIF, DXF and EPS format to help you create diagrams. All files are packed as Zip archives. The files can be unpacked using Winzip (PC) or Ziplt (MAC).

Information

Current diagrams are available for downloading from the CustomizedSolution Portal (CSP) of Volkswagen AG under the “Foil templates” menu item.

6.3 Current flow diagrams

For detailed information about this topic, refer to the workshop manuals and circuit flow diagrams of Volkswagen AG.

Information

Volkswagen AG workshop manuals and circuit diagrams can be downloaded from the Internet at **erWin*** (Electronic Repair and Workshop Information from Volkswagen AG):
<http://erwin.volkswagen.de/erwin/showHome.do>

*Information system from Volkswagen AG, subject to payment

6.4 CAD models

As a registered converter, you can receive 3-D data models in the formats CATIA V.5 and STEP for design purposes.

Information

The available 3D data can be found on the CustomizedSolution Portal (CSP) of Volkswagen AG under “Technical information/CAD data”*.

*Registration required.

7 Weights (masses)

When ordering your vehicle, please note that the kerb weight increases when additional equipment is selected and the available payload capacity is therefore reduced.

Due to the continual changes to the base vehicle, all vehicle weights are available via the country-specific sales documents on the Internet or via the CustomizedSolution portal (www.customized-solution.com).

We recommend determining the definitive kerb weight of the entire vehicle by weighing before the conversion.

For further questions, please contact your Volkswagen Commercial Vehicles dealer, your importer or our Customer Care (see [chapter 1.2.1.1 "Contact in Germany"](#), [1.2.1.2 "International contact"](#)).

Practical note

For vehicle earth/dimensions, the following weight tolerances apply:

- 3% for vehicle classes M/N (except vehicles with special intended use)
- 5% for vehicles with special intended use

8 Homologation

8.1 Notes on homologation of modifications and conversions

Complete vehicles that have been modified with add-ons/conversions after completion at the OEM plant and before initial registration must resubmit CO₂/consumption values for the second stage.

These can be identified using the WLTP calculator in accordance with the available homologations. Options for calculating weight and/or aerodynamic changes are available.

If individual values are not available for the respective conversion, it is possible to apply for homologation in consultation with the technical service and the regulatory authorities.

The following engine/gearbox variants and drives with complete CoC ex works are available with homologation type N1:

1. 2.0-l diesel 125-kW 4x4 6-speed manual gearbox with the Euro 6d ISC-FCM emission standard
2. 2.0-l diesel 151-kW 4x4 10-speed automatic gearbox with the Euro 6d ISC-FCM emission standard

(Not for vehicles with V6 diesel engines)

Information

In order to enable the vehicle to be homologated after the installation of conversions and installations, it is essential to select the additional equipment **PR no. 5EK** "Conversions (ISC parameter calculations possible)". This involves the following changes:

- Modified exhaust system
- Limitation of maximum speed to 130 km/h. **Caution:** Limit can no longer be undone!
- Entry of an increased CO₂ value in the vehicle registration

Calculation for conversions with weight changes, changes to the front surface and rolling resistance are possible in the Customized Solution Portal (WLTP calculation tool).

Permissible ISC parameters for the Amarok with double cab when using the emission values of the base vehicle.

Parameters	From	to	Comment
Mass in road-ready state [kg]	(125 kW) 2,089 (151 kW) 2,375	2,711 2,717	The maximum mass may not be exceeded.
Front surface [cm ²]	29,400	41,000	The maximum permitted front surface area shall not be exceeded.
Rolling resistance of tyres [kg/to]	5.9	12.9	The values have been determined using the approved standard tyres.
Free radiator inflow area [cm ²]	1,005		The standard radiator inflow area must not be modified.

Information

For all vehicles / engine-gearbox variants for which no values can currently be generated using the WLTP calculation tool, please contact your responsible technical service and check whether individual approval or multi-stage type approval is possible.

9 Listings

9.1 List of changes

Modifications to the converter guidelines compared to the data status of December 2023.

Chapter no.	Chapter heading	Scope of change
1	General information	
1.1	Introduction	
1.1.1	Concept of this Owner's Manual	Chapter updated
1.1.2	Means of representation	
1.1.3	Vehicle safety	
1.1.4	Operational safety	
1.1.5	Note on copyright	
1.2	General information	
1.2.1	Product and vehicle information for converters	
1.2.1.1	Contact in Germany	
1.2.1.2	International contact	
1.2.1.3	Electronic Repair and Workshop Information from Volkswagen AG (erWin)	
1.2.1.4	Genuine Parts Online Ordering Portal*	
1.2.1.5	Online Owner's Manual	
1.2.1.6	European Type Approval (ETA) and EC Certificate of Conformity (CoC)	
1.2.1.7	Worldwide Harmonised Light Vehicles Test Procedure (WLTP)	
1.2.2	Converter guidelines, consulting	
1.2.2.1	Letter of non-objection	
1.2.2.2	Application for the letter of non-objection	
1.2.2.3	Legal entitlements	
1.2.3	Warranty and product liability of the converter	
1.2.4	Ensuring traceability	
1.2.5	Badges	
1.2.5.1	Positions on rear of the vehicle	
1.2.5.2	Appearance of whole vehicle	
1.2.5.3	Non-Volkswagen badge	
1.2.6	Recommendations for vehicle storage	Chapter updated
1.2.7	Compliance with environmental rules and regulations	
1.2.8	Recommendations for inspection, maintenance and repair	

Chapter no.	Chapter heading	Scope of change
1.2.9	Accident prevention	
1.2.10	Quality system	
1.3	Planning bodies	
1.3.1	Selecting the basic vehicle	
1.3.2	Vehicle modifications	
1.3.3	Vehicle acceptance	
1.4	Special equipment	
1.5	Commercial aspects	
1.5.1	Restraint system	
1.5.2	Drilling and welding	
1.5.3	Minimum requirements for the brake system	
1.5.4	Road safety	
1.6	Electromagnetic compatibility (EMC)	Chapter updated
1.6.1	Pickup	
1.7	Raising the vehicle with a jack	
1.7.1	Vehicle jacking points and axle stand positions	
1.8	Raising the vehicle with a lifting platform	
1.9	Noise, vibration and harshness (NVH)	
1.10	Vehicle transport aids and vehicle storage	
1.11	Assemblies and ergonomics	
1.11.1	General guidelines for assemblies	
1.11.2	Driver's operating area	
1.11.3	Driver's field of vision	
1.11.4	Effects of conversions on parking aids	
1.11.5	Aids for entering and exiting vehicles	
1.11.6	Worldwide Harmonised Light Vehicles Test Procedure (WLTP) calculation inputs	Chapter updated
1.11.7	Mass of the finished vehicle	
1.11.8	Frontal surface	
1.11.9	Rolling resistance of tyres	
1.11.10	Key to vehicle dimensions	Chapter updated
1.11.11	Recommended main load range dimensions	Chapter updated
1.11.12	WLTP front area calculation	
1.11.13	Code	
1.12	Assemblies and ergonomics – specifications	
1.12.1	Recommended body dimensions	Chapter updated
1.12.2	Technical data for planning/base vehicle	
1.12.3	Unladen mass and payload	
1.12.4	Gross vehicle mass and axle load	

Chapter no.	Chapter heading	Scope of change
1.12.5	Front, rear and side underbody protection	
1.12.6	Rear skid plate – chassis with cab	
1.13	Components – specifications	
1.14	Load distribution – specifications	
1.14.1	Load distribution calculations – weight distribution of driver and front passenger	
1.14.2	Centre of gravity	
1.15	Towing brackets	
1.15.1	Requirements for the towing brackets	
1.15.2	Use of the towing bracket	
1.15.3	Towing capacities and specifications	
2	Chassis	
2.1	Running gear suspension	
2.2	Brake system	
2.2.1	General information	
2.2.2	Brake hoses	
2.2.3	Overrun brake connection	Chapter updated
3	Drive train	
3.1	Motor	
3.1.1	Air flow areas of the engine cooling system	
3.1.2	Engine selection for conversions	
3.2	Fuel system	
3.2.1	Securing the fuel filler pipe during transport	
3.2.2	Securing the fuel filling system	Chapter updated
3.2.3	Breather hose for fuel filling system (diesel)	
3.2.4	Breather hose for axle venting	
3.2.5	Fuel tanks with a big fuel range	Chapter added
3.3	System for “Selective Catalytic Reduction (SCR)”	
3.3.1	Selective catalytic reduction system – diesel exhaust fluid (reducing agent)	Image at top of page 71 updated
4	Electrical	
4.1	Installation and routing guidelines for electrical wiring	
4.1.1	Wiring splicing method	
4.1.2	Cable guide through cab panel	
4.2	Battery and cables	
4.2.1	Battery information	Chapter updated
4.2.2	Connection of additional loads/accessories – for vehicles with factory-installed additional switches, wiring and fuse boxes	
4.2.3	Alternator	Chapter updated

Chapter no.	Chapter heading	Scope of change
4.2.4	Ignition signal	Chapter updated
4.3	Park Distance Control	
4.3.1	Sensor positions	
4.4	Engine management system	
4.4.1	Tachograph	
4.4.2	Vehicle speed signal	Chapter updated
4.5	Information and multimedia system	
4.5.1	Rear view camera system	
4.6	Exterior lighting	
4.6.1	Rear combination lights	
4.6.2	Rear fog light	
4.6.3	Rear number plate lights	
4.6.4	Additional external lights	
4.6.5	Headlights – connecting an additional main beam signal	Chapter updated
4.6.6	Brake lights	
4.6.7	Side marker lights (parking lights)	Chapter updated
4.6.8	Reversing lights, reversing camera, reversing alarm (manual gearbox)	
4.6.9	Towing mode – lighting connections	Chapter updated
4.6.10	Lights – hazard warning lights / turn signals	
4.6.11	Electrically operated exterior mirrors	
4.6.12	High-mounted centre brake light	
4.6.13	Automatic main beam	
4.6.14	Dazzle-free main beam	
4.6.15	Parking brake signal	Chapter added
4.7	Cruise control system	
4.7.1	Adaptive cruise control	
4.8	Driver assist systems	Chapter updated
4.9	Overhead view camera – Area View	
4.10	Side view camera	
4.11	Lane departure warning (Lane Assist)	
4.12	Handles, locks, locking elements and access systems	
4.12.1	Central locking	
4.13	Fuses and relays	
4.13.1	Fuses	
5	Body and paint	
5.1	Structure	
5.1.1	Body structures – general information	
5.1.2	Add-on parts on the vehicle frame , wheel housing cover	

Chapter no.	Chapter heading	Scope of change
5.1.3	Chassis frame	
5.1.4	Integrity of the front section for cooling, collision, aerodynamics and lighting	
5.1.5	Tipper bodies	
5.1.6	Tank and bulk container superstructure	
5.1.7	Aerial cable routing	
5.1.8	Roof loads and roof carriers	
5.1.9	Add-on parts on the cargo box	Chapter updated
5.1.10	Front wing trim	
5.2	Airbag systems	
5.2.1	Airbags	Chapter updated
5.2.2	Additional impact sensors (front)	
5.3	Seat belt systems	
5.3.1	Seat belts – permitted drilling zones	
5.4	Corrosion protection	
5.4.1	General information	
5.4.2	Touching up damaged paintwork	
5.4.3	Underseal and materials	
5.4.4	Painting rims	
5.4.5	Galvanic (bi-metallic) corrosion / contact corrosion	
5.5	Frame and body mounting	
5.5.1	Mounting points and tubes	
5.5.2	Removing rear seats	Chapter added
5.5.3	Self-supporting body structure	Chapter number changed
5.5.4	Frame drilling and tube reinforcement	Chapter number changed
5.5.5	Additional equipment – subframe attachment	Chapter number changed
5.5.6	Area for fitting additional body attachments to the rear of the bumper	Chapter number changed
5.5.7	Water tank on camping vehicles	Chapter number changed
5.5.8	Conversions with an extended wheelbase	Chapter number changed; chapter updated
6	Technical data	
6.1	Build dimension drawings	
6.2	Diagrams (foil templates)	Chapter updated
6.3	Current flow diagrams	
6.4	CAD models	
7	Weights (masses)	
8	Homologation	
8.1	Notes on homologation of modifications and conversions	
9	Listings	

Chapter no.	Chapter heading	Scope of change
9.1	List of changes	References added
	Title, Brieffach, issue date	

Converter guidelines

The new Amarok

Converter guidelines

Subject to change without notice

Edition October 2024

Internet:

<https://www.volkswagen-nutzfahrzeuge.de>

<https://www.customized-solution.com>

Consulting for converters in Germany is available from the listed address.

Volkswagen Commercial Vehicles

Brieffach 2949

Postfach 21 05 80

D-30405 Hannover